

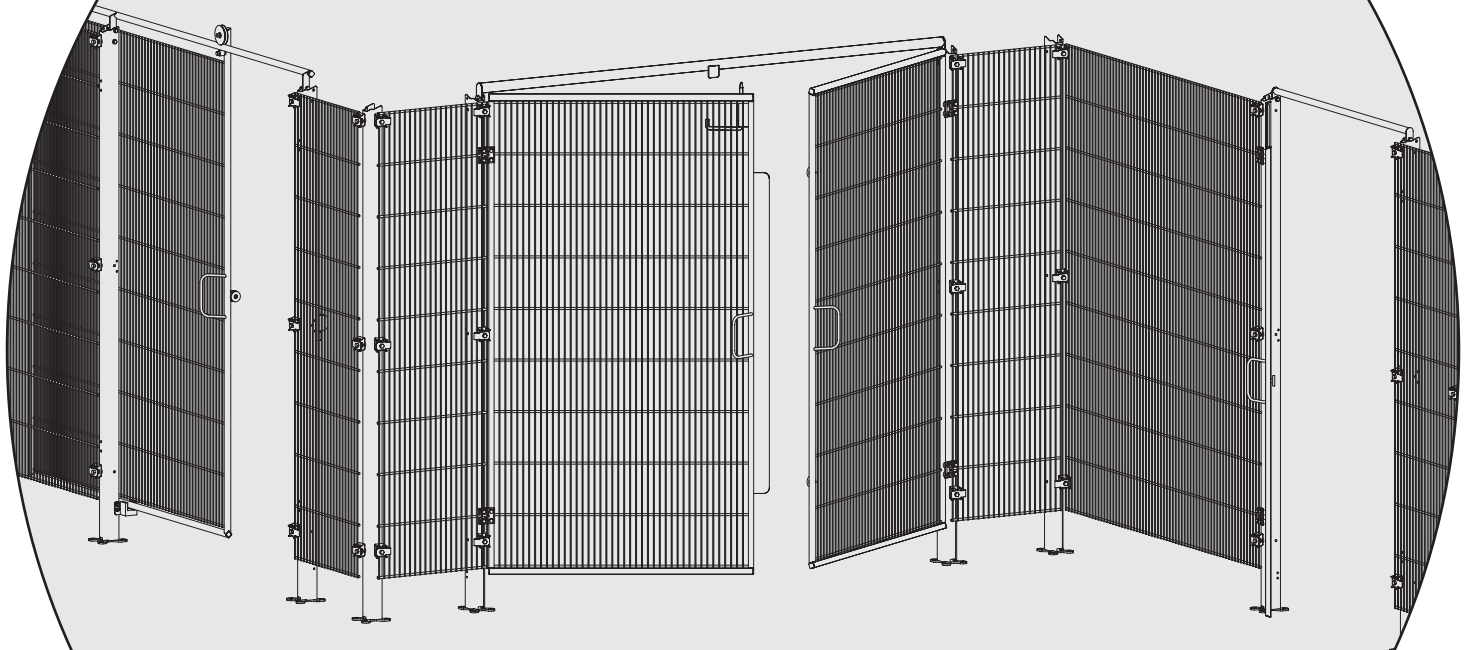

This operating manual contains important product information and safety instructions. Read and follow the safety instructions before carrying out any activities related to this product. Make this operating manual accessible for all entities involved, and store it carefully.



...we protect people!



ORIGINAL OPERATING MANUAL

HYGIENEFENCE® Stainless steel protective fencing system

System height 2000 mm
Edition: 10/2019





A series of horizontal dotted lines spanning the width of the page, providing a guide for handwriting practice.

Table of Contents

| | | |
|---------------|---|---------------------|
| 1. | Product description and technical data | Page 04 - 05 |
| 2. | Intended usage and limits of usage | Page 06 |
| 3. | EC declaration of type conformity | Page 07 |
| 4. | Safety instructions and explanation of symbols | Page 08 |
| 5. | Assembly and installation | Page 09 - 10 |
| 5.1. | Assembly of fence elements | Page 11 - 19 |
| 5.2. | Assembly of doors | Page 20 - 21 |
| 5.2.1. | 1-leaf revolving door (left and right) | Page 22 - 31 |
| 5.2.2. | 2-leaf revolving door | Page 32 - 37 |
| 5.2.3. | 1-leaf sliding door (left and right) | Page 38 - 53 |
| 5.3. | Providing openings in fence elements | Page 54 |
| 6. | Cleaning | Page 54 - 55 |
| 7. | Maintenance | Page 56 |
| 8. | Dismantling and disposal | Page 56 |
| 9. | Accessories | Page 57 |

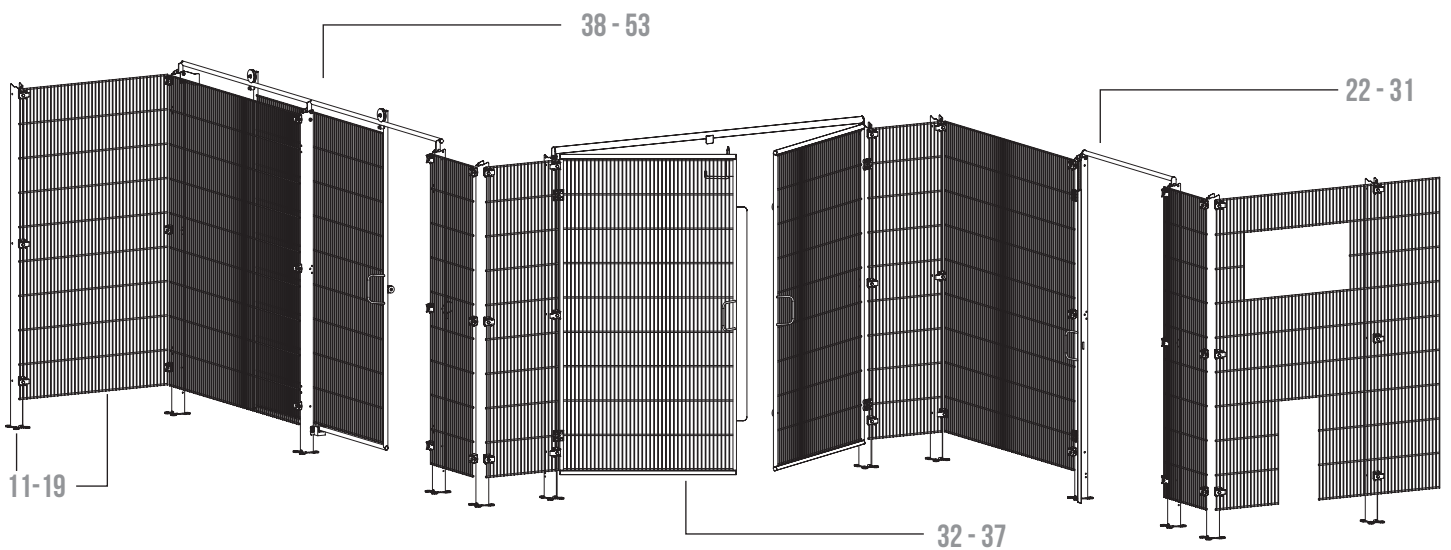

1. Product description and technical data

The HYGIENEFENCE® protective fencing system primarily comprises fence elements and doors. These basic components are generally available in the following models:

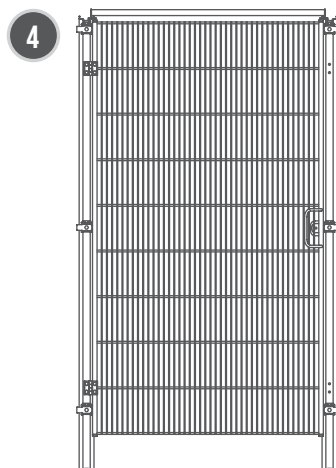
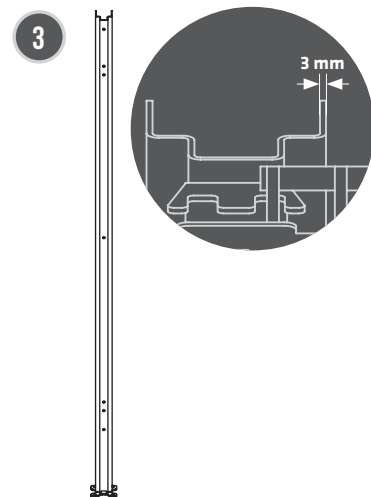
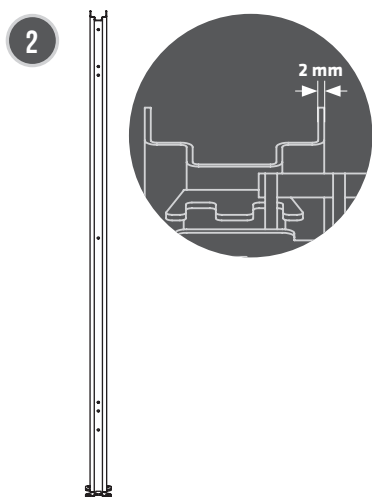
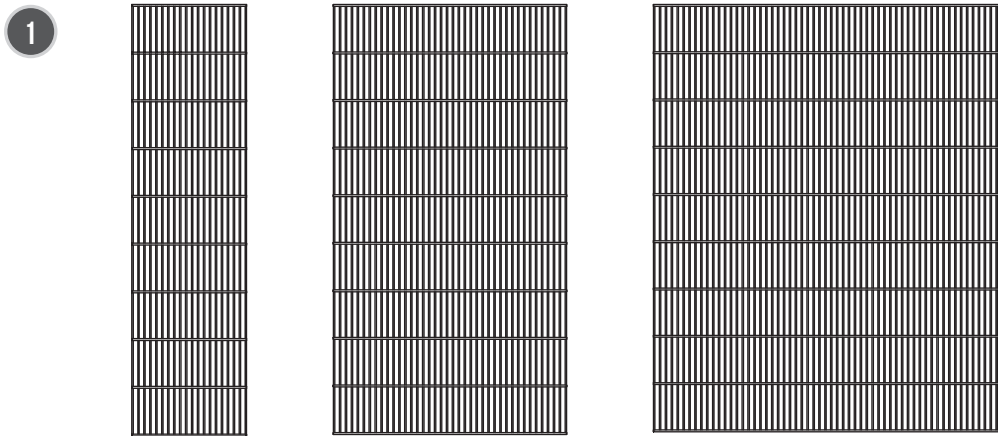

1. Product description and technical data

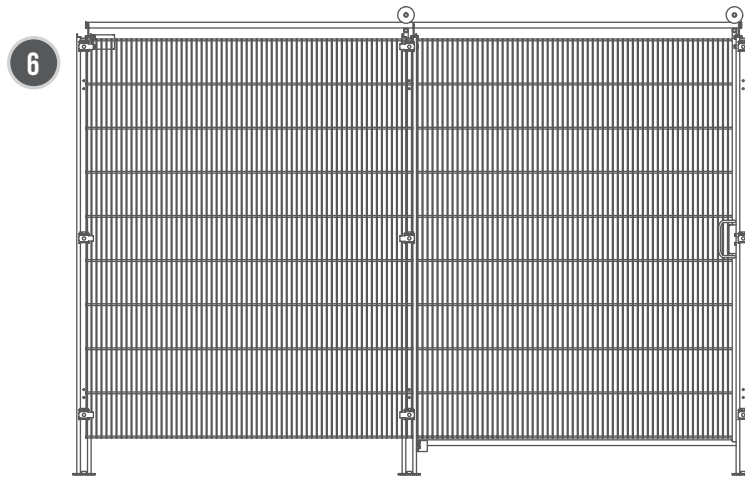
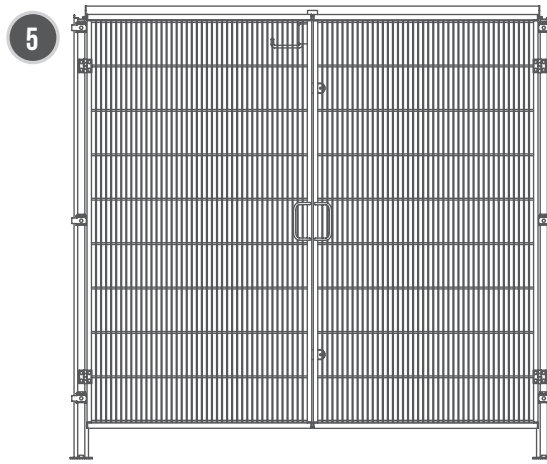

| | HYGIENEFENCE® | Axis dimension - widths (mm) | Passage width (mm) | Heights: (mm) | Weights: (kg) |
|---|------------------------|-------------------------------------|---------------------------|----------------------|----------------------|
| 1 | Fence elements: | 500 | -- | 1800 | 5,9 |
| | | 1000 | -- | 1800 | 11,8 |
| | | 1500 | -- | 1800 | 17,7 |
| 2 | Post: | 60/60 | -- | 2000 | 6,0 |
| 3 | Door assembly post: | 60/60 | -- | 2000 | 8,4 |
| 4 | 1-leaf revolving door: | 1065 | 910 | 2027 | 34,5 |
| 5 | 2-leaf revolving door: | 2084 | 1940 | 2039 | 58,2 |
| 6 | 1-leaf sliding door: | 2989 | 1250 | 2039 | 73,2 |

2. Intended usage and limits of usage



The HYGIENEFENCE® protective fencing system is intended as a separating distance protection device to protect persons from accessing hazard areas on machines and systems in the food-stuff industry (e.g. bakeries, pharmacy, meat product companies, cheese factories and dairies). Fence elements are suitable for use as stationary separating protection devices and the doors, in combination with locking devices (as per ISO 14119), are intended for movable separating protection devices (as per DIN EN 953). Locking devices and their fastening accessories are not a part of the scope of delivery. The system manufacturer is responsible for the professional design and installation of suitable locking devices. Expertise also includes the knowledge of and adherence to prevailing safety regulations - DIN EN ISO 13849 among others. Affixing the provided CE mark (type plate) is prohibited until the doors are equipped with essential locking devices.



Any other usage requires a written permission by the manufacturer.



Intended usage also includes knowledge of and adherence to this operating manual.



**This system is not intended for use in outdoor areas.
Exposure to saline sea air is not allowed.**



TIEMANN
Schutz-Systeme GmbH
Lübbecker Straße 16
32257 Bünde | Germany

T+49 (0)5223 791995-0
F+49 (0)5223 791995-90

info@hygienefence.com
www.hygienefence.com

EG-KONFORMITÄTSERKLÄRUNG

im Sinne der EG Maschinenrichtlinie 2006/42/EG, Anhang II A

EC DECLARATION OF CONFORMITY

according to EC Machinery Directive 2006/42/EC, Annex II A

Hersteller | Manufacturer

Tiemann Schutz-Systeme GmbH
Lübbecker Str. 16
32257 Bünde / Germany

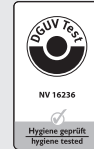

Hiermit erklären wir, dass das Produkt:

Produktbezeichnung: **Trennvorrichtung Schutzeinrichtung**
Typ: **HYGIENEFENCE®**
Baujahr bzw. Seriennummer: **ab 05/2016**

den einschlägigen Bestimmungen der Richtlinie 2006/42/EG und der Verordnung (EG) Nr. 1935/2004 entspricht.

Es wurden folgende harmonisierte Normen angewandt:

- DIN EN ISO 14120:2016-05
- DIN EN 1672-2:2009-07

We hereby declare that the product:

Product designation: **Separating guard**
Type: **HYGIENEFENCE®**
Year of build or serial number: **as of 05/2016**

meets the relevant provisions of directive 2006/42/EC.

The following harmonised standards have been applied:

- DIN EN ISO 14120:2016-05
- DIN EN 1672-2:2009-07

Bünde,
Ort
City

Datum
Date







Unterschrift*
Signature*

Axel W. Tiemann
Geschäftsführer
Managing Director

* Der Unterzeichner ist verantwortlich für die Zusammenstellung der technischen Unterlagen und gleichzeitig der verantwortliche Herausgeber der technischen Dokumentation.
The signatory is responsible for the composition of the technical documents and at the same time the responsible publisher of the technical documentation.

4. Safety instructions and explanation of symbols

Refer to the corresponding sections in this operating manual for safety instructions and adhere to them.

| Symbol | Explanation |
|---|---|
|  | Safety instruction (Non-adherence may lead to the risk of injuries and/or life) |
|  | Function instruction (Non-adherence may lead to functional faults and/or material damage) |
|  | Hazard area |
|  | No hazard area |
|  | Enlarged view / detailed view |
|  | Assembly height |
|  | Required tool (refer to page 10) |

5. Assembly and installation



Two persons are required for the assembly and installation.

Only experts may carry out assembly and installation.

Before starting installation, switch off the machine or the system to be fenced, or bring it to a safe condition.

Determine/check the essential safety distances from hazard areas of the machine/system as per DIN EN ISO 13857:

Safety distances DIN EN ISO 13857

(upper/lower limbs)

Hazard area distance for: System height 2000 mm

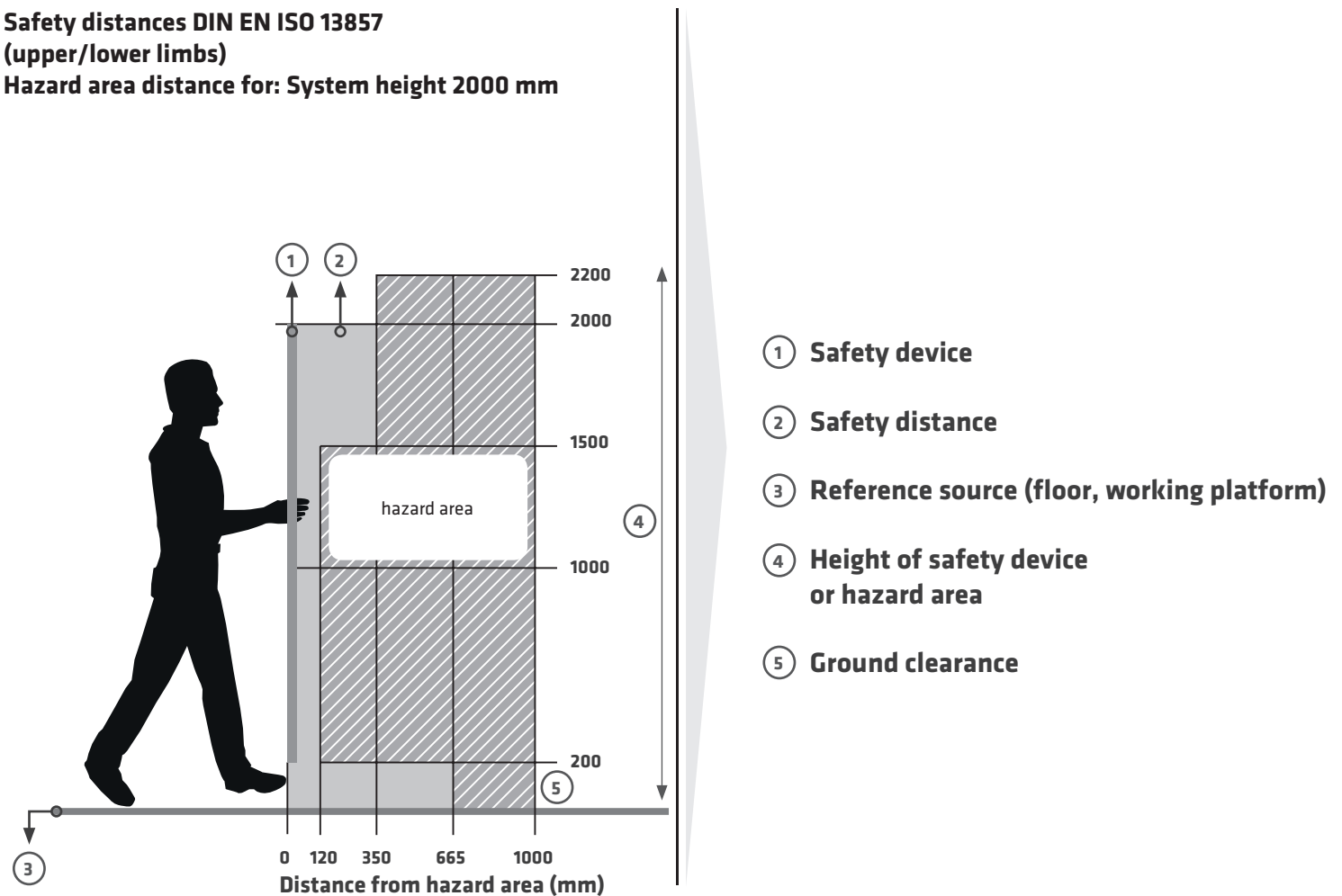

Information regarding dimensions and weights of system parts is given in section 1. Technical data, pages 4 - 5.





This system is exclusively intended for installation on industrial concrete floors (see page 12).

Use only the provided fastening aids.

When installing electrical devices (e.g. cables, switches, switch cabinets, etc.) on the protective fencing system, adhere to the requirements of DIN EN 60204-1.

❓ If you have any questions, contact our service staff at 05223.791995-0.

5. Essential tools

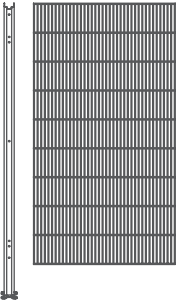
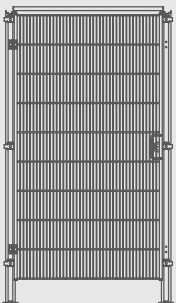
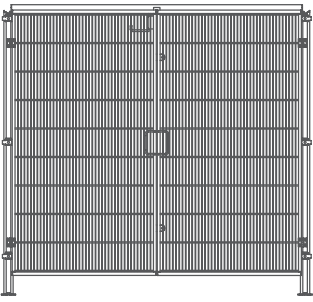
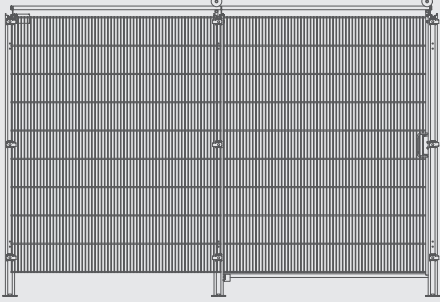
| Product | Tools  |
|---|---|
|  <p>Post (pages 12 - 15)</p> | <p>Drilling machine with 10-mm concrete driller Hammer Box spanner 13 mm Box spanner 14 mm</p> |
|  <p>Fence assembly (pages 16 - 19)</p> | <p>Box spanner 13 mm Box spanner 14 mm</p> |
|  <p>1-leaf revolving door (pages 22 - 31)</p> | <p>Allen key 3 mm Open-end spanner 8 mm Open-end spanner 10 mm Box spanner 13 mm Box spanner 14 mm</p> |
|  <p>2-leaf revolving door (pages 32 - 37)</p> | <p>Allen key 3 mm Open-end spanner 8 mm Open-end spanner 10 mm Box spanner 13 mm Box spanner 14 mm</p> |
|  <p>1-leaf sliding door (pages 38 - 53)</p> | <p>Allen key 3 mm Open-end spanner 8 mm Open-end spanner 10 mm Box spanner 13 mm Box spanner 14 mm</p> |

5.1. Assembly of fence elements (posts and fence)

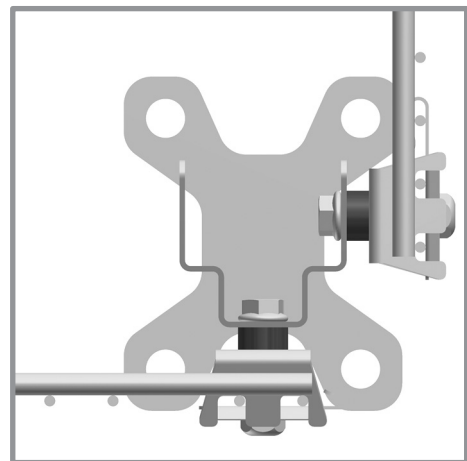
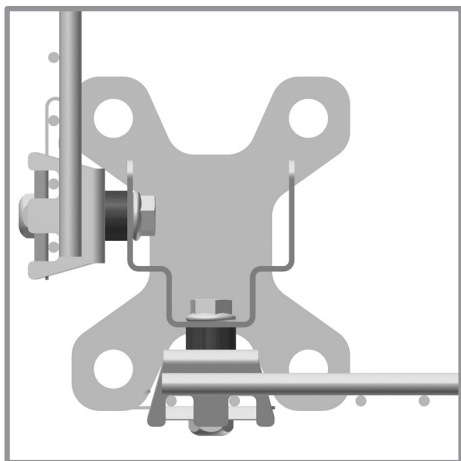
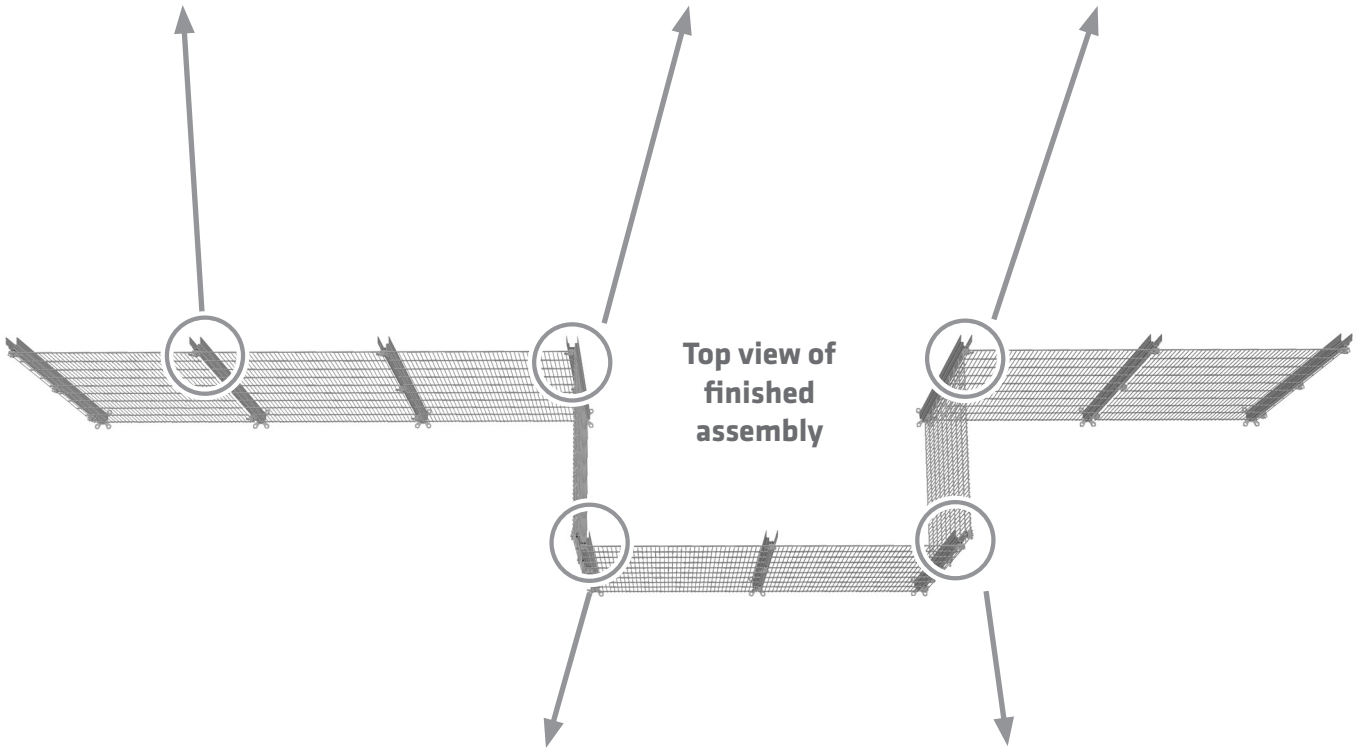
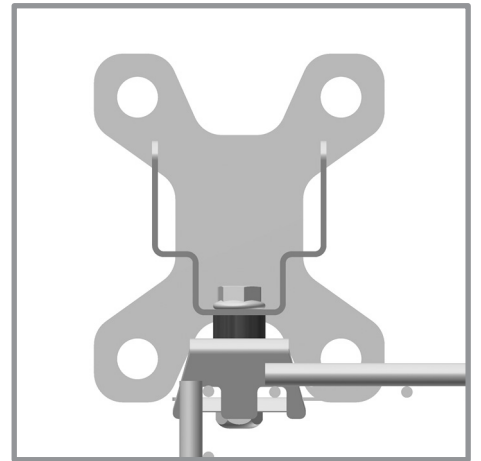
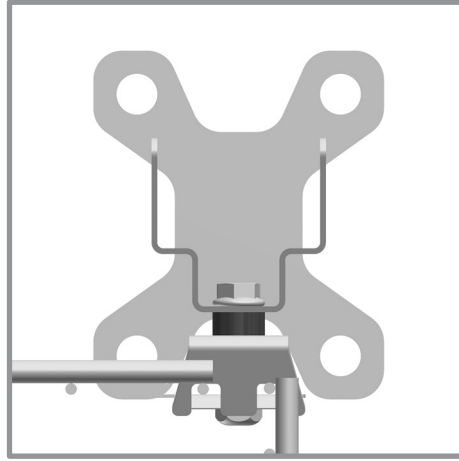
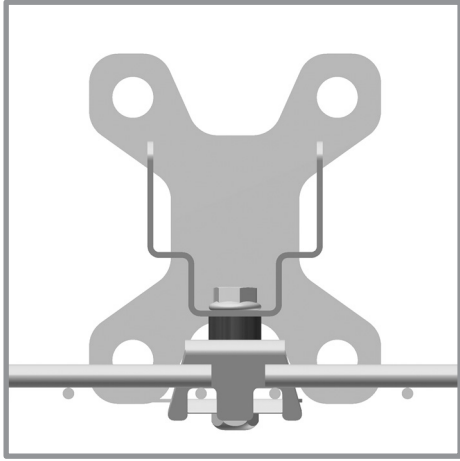
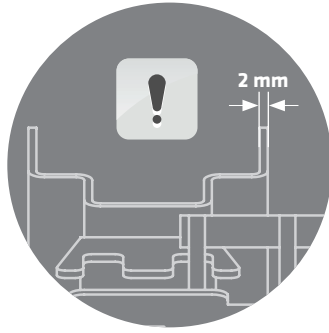

5.1. Assembly of fence elements (posts and fence)



Refer to page 10

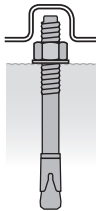
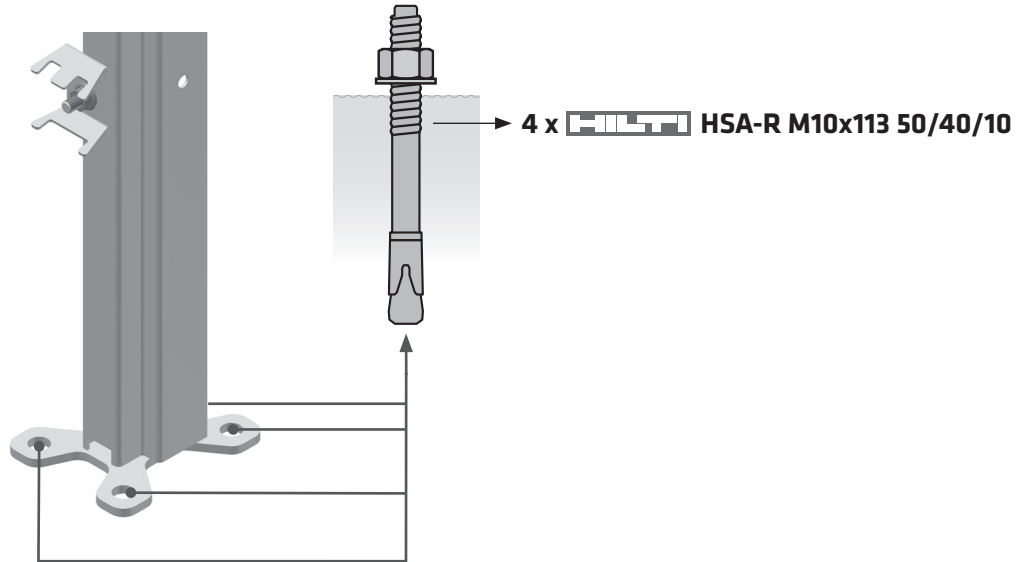
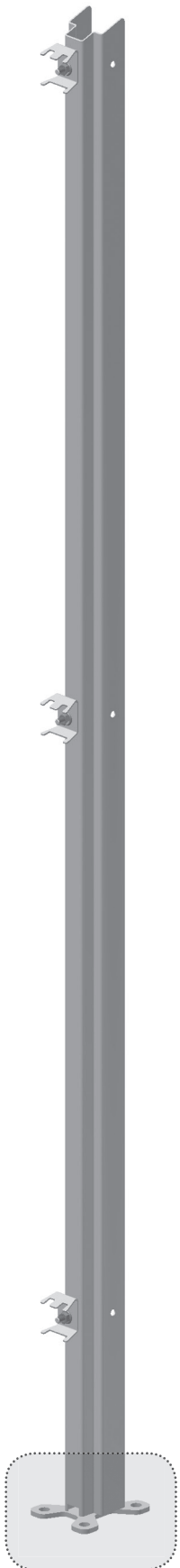

Cover remaining open threads and thread ends.

Technical data:

| | |
|------------------------------------|--|
| Dowel size: | M10 |
| Dowel length: | 113 mm |
| approvals | ETA |
| Base material: | concrete (non-cracked) C20/25 to C50/60 |
| Weather effects: | indoor, dry |
| Edge distance: | 40 mm |
| Working principle: | Torque controlled expansion |
| Standard setting depth: | 90 mm |
| Driller nominal diameter: | 10 mm |
| Drill hole depth: | 95 mm |
| Required tightening torque: | 25 Nm |

5.1. Assembly of fence elements (posts and fence)

row post

Order no. YURP2000

1 x ZB31098

1 3 x DIN6921 A2 M8x30

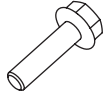

2 3 x VA-R 00031



3 3 x VA-B00030

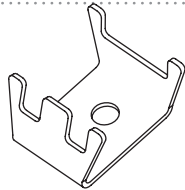

4 3 x DIN6923 A2 M8



5 3 x ZB31046

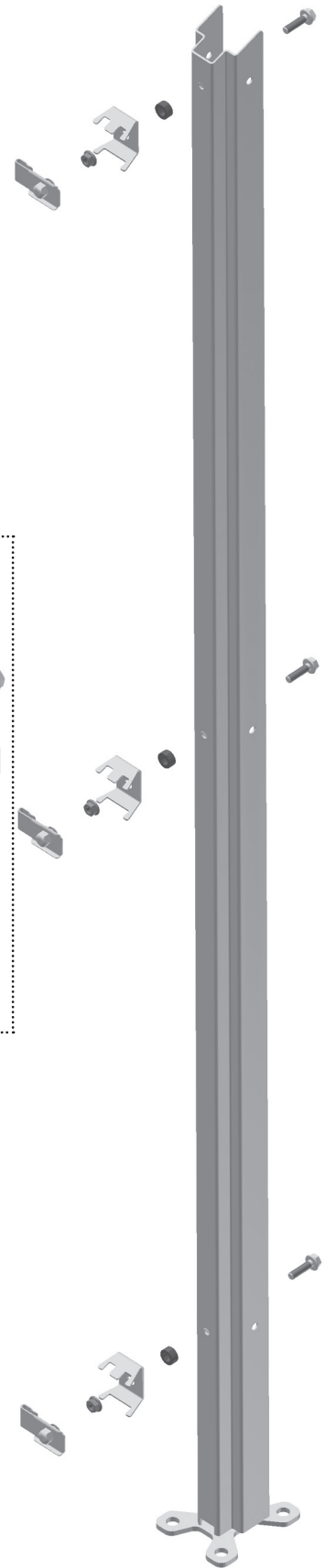
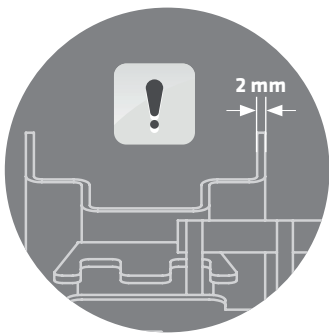
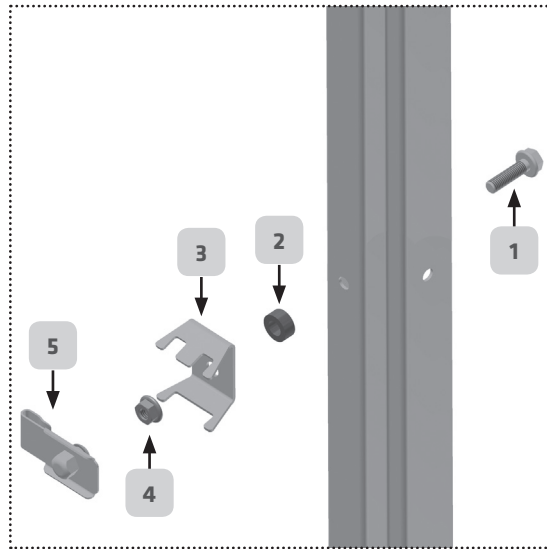
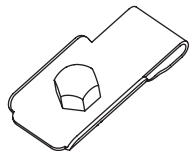

5.1. Assembly of fence elements (posts and fence)



Refer to page 10

Corner post left assembly version

Order no. YUEPLR2000

2 x ZB31098

1 3 x DIN6921 A2 M8x30



2 3 x VA-R 00031



3 3 x VA-B00030

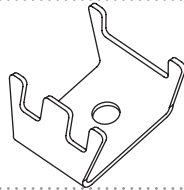

4 3 x DIN6923 A2 M8



5 3 x ZB31046

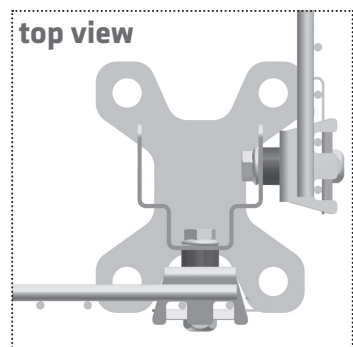
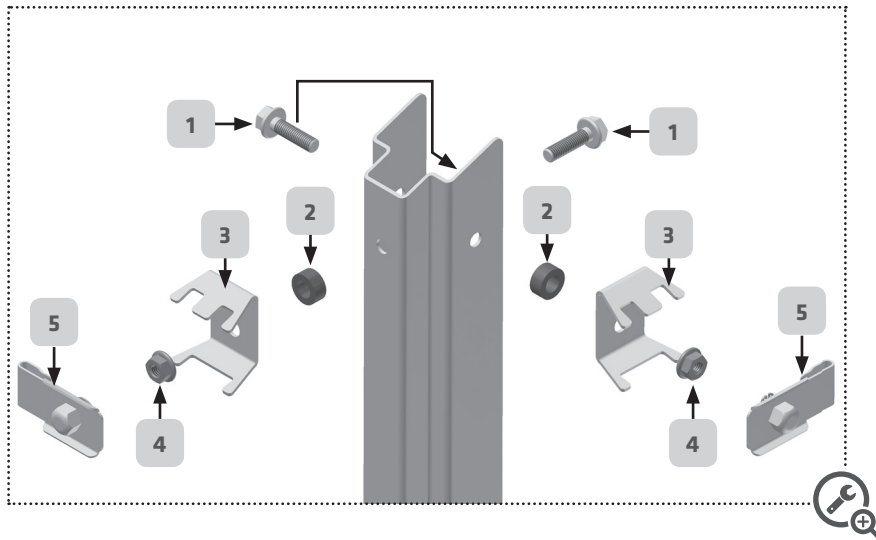
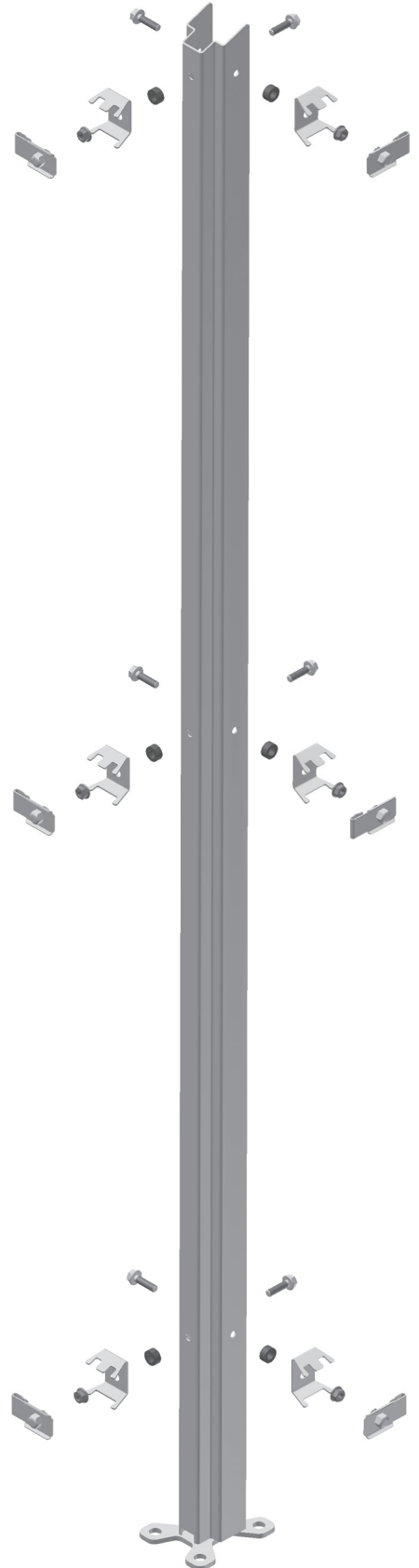
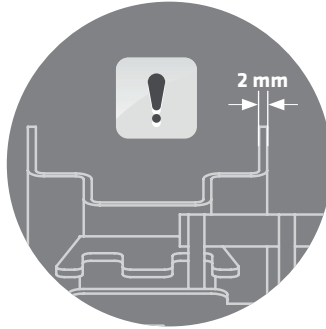
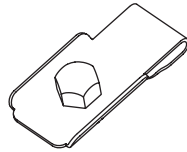



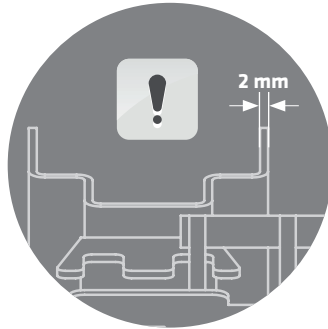

5.1. Assembly of fence elements (posts and fence)

Corner post right assembly version

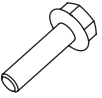
Order no. YUEPLR2000

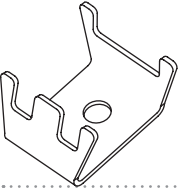

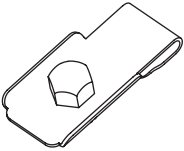
| 2 x ZB31098 | | |
|-------------|----------------------|---|
| 1 | 3 x DIN6921 A2 M8x30 |  |
| 2 | 3 x VA-R 00031 |  |
| 3 | 3 x VA-B00030 |  |
| 4 | 3 x DIN6923 A2 M8 |  |
| 5 | 3 x ZB31046 |  |

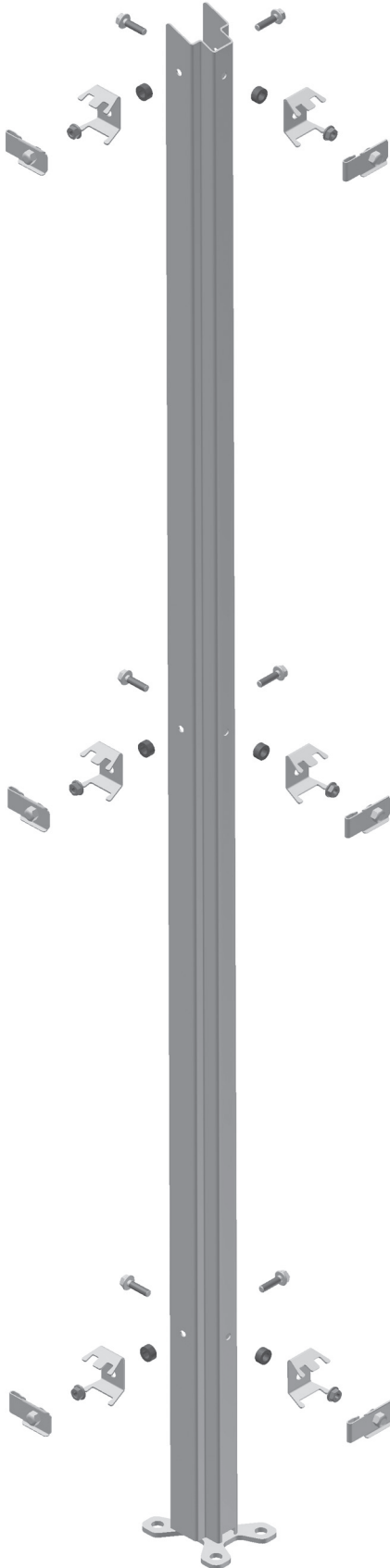
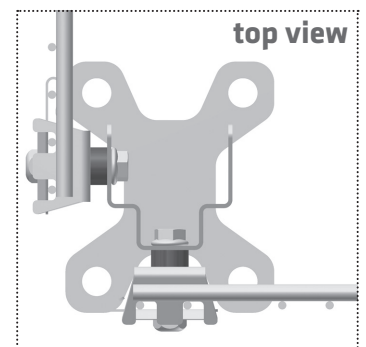
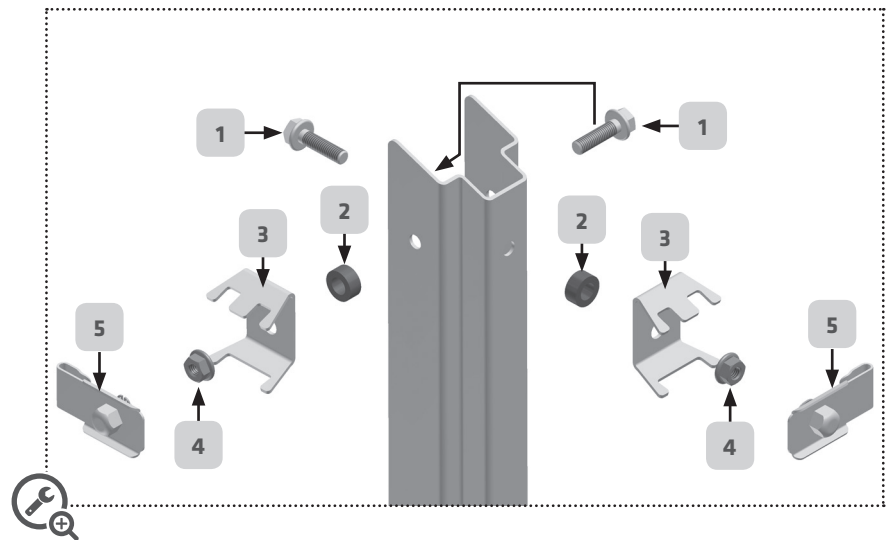

5.1. Assembly of fence elements (posts and fence)



Refer to page 10

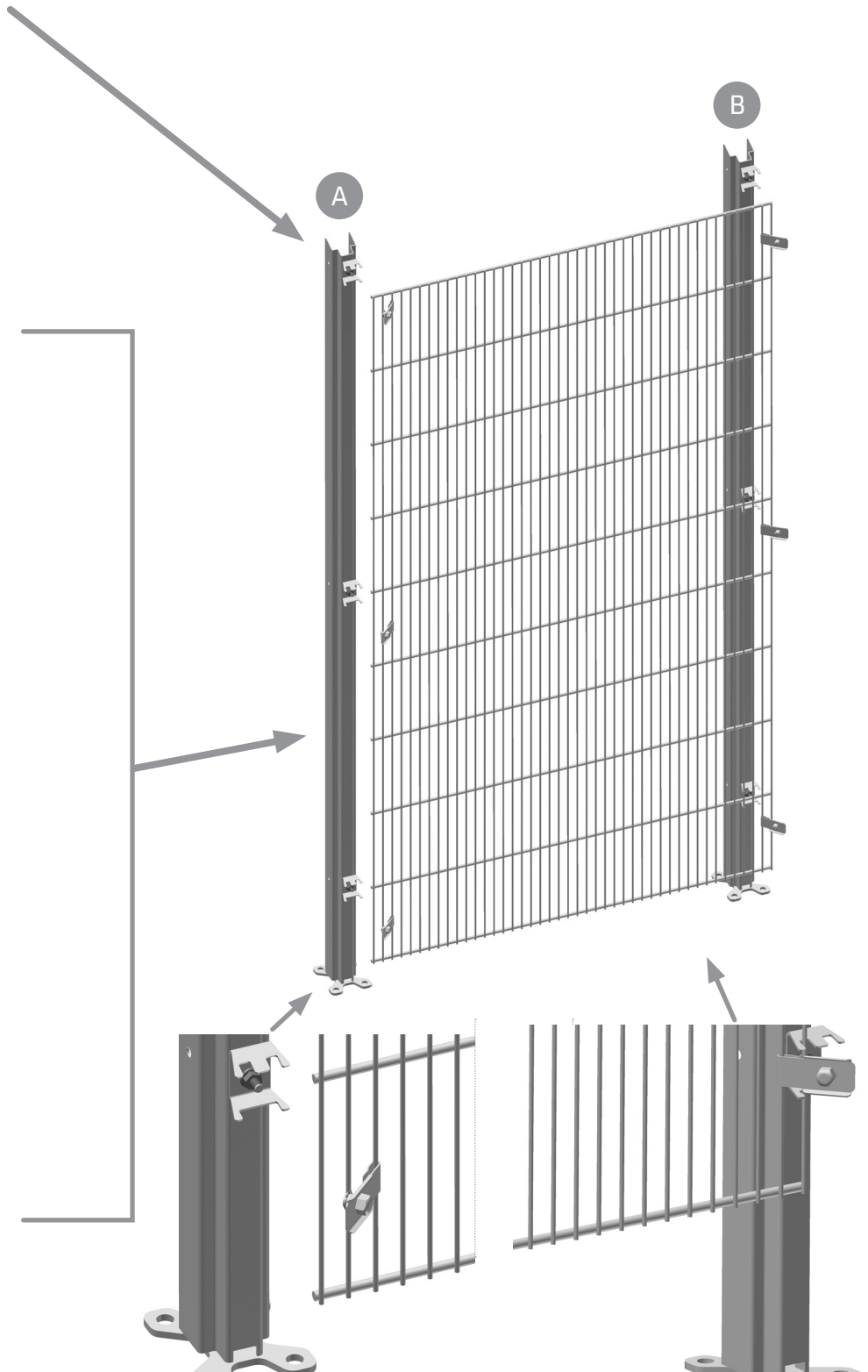
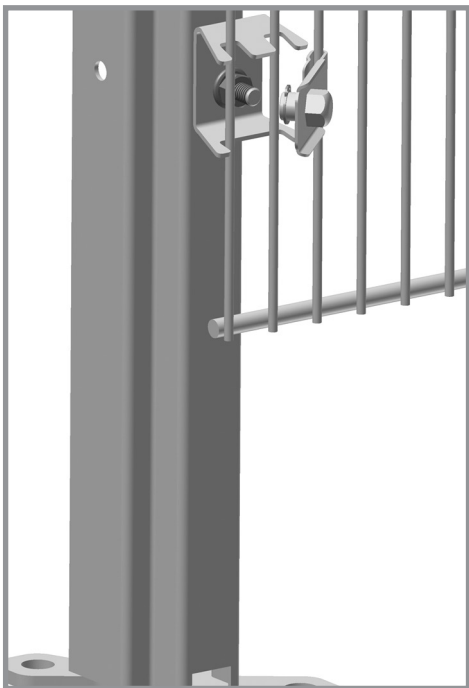
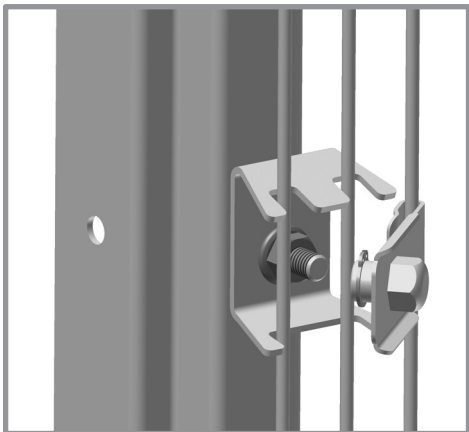
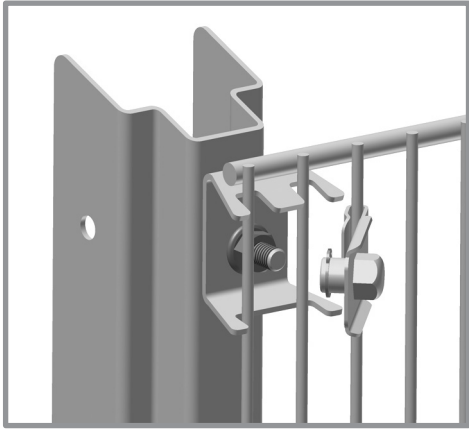
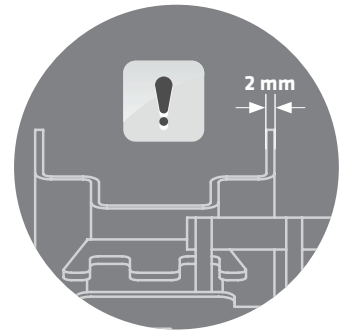

5.1. Assembly of fence elements (posts and fence)

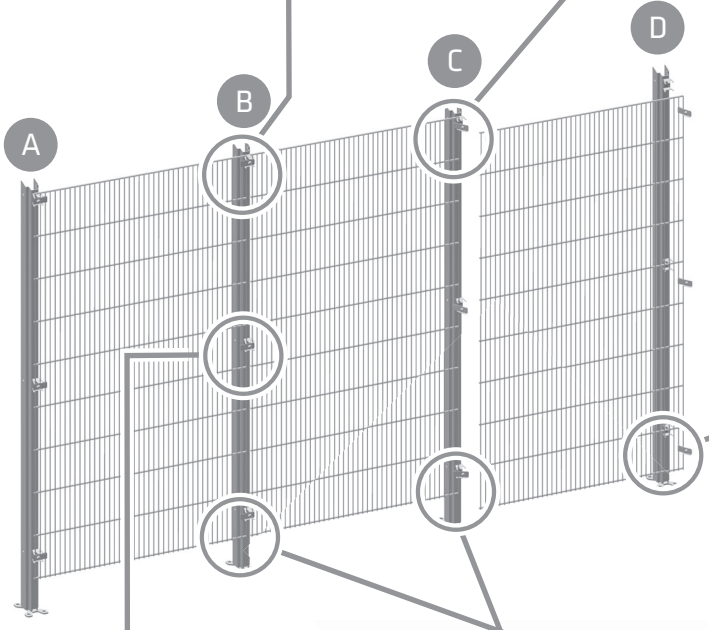
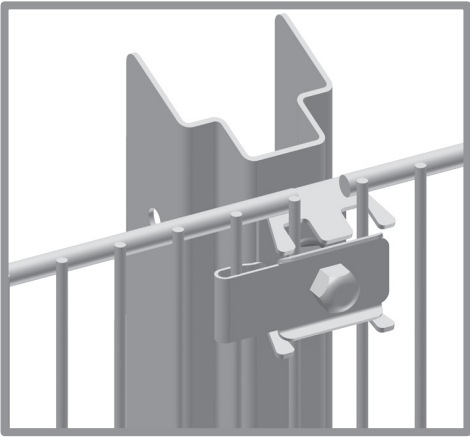
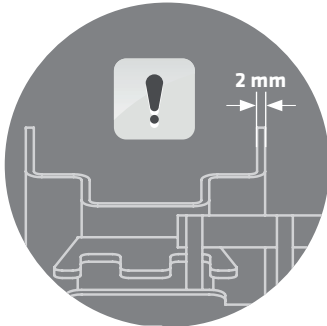

5.1. Assembly of fence elements (posts and fence)

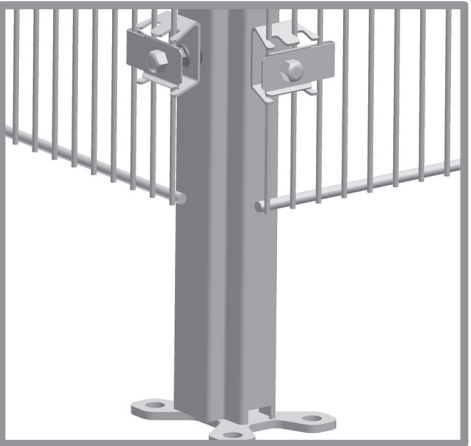
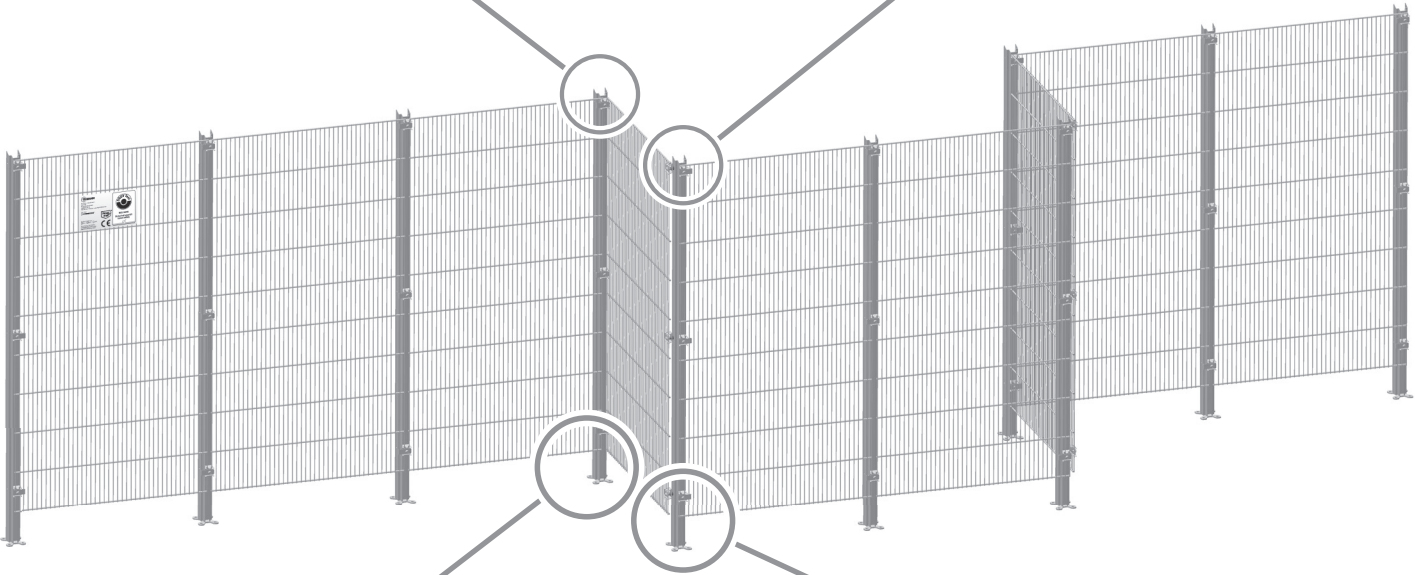
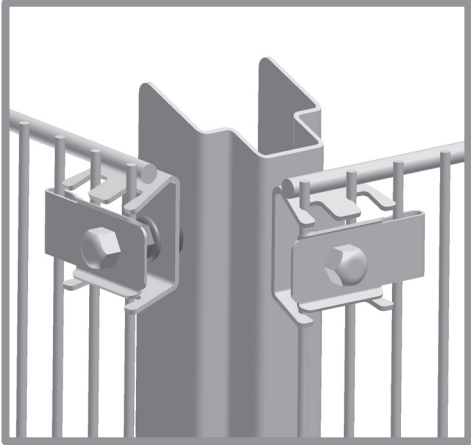
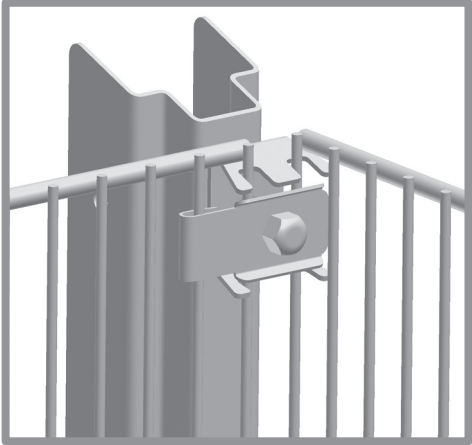
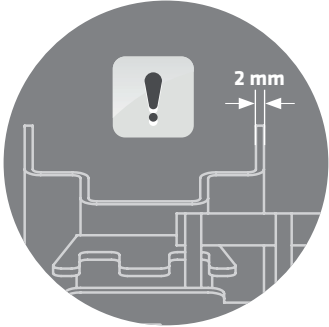

5.2. Assembly of doors | Assembled view

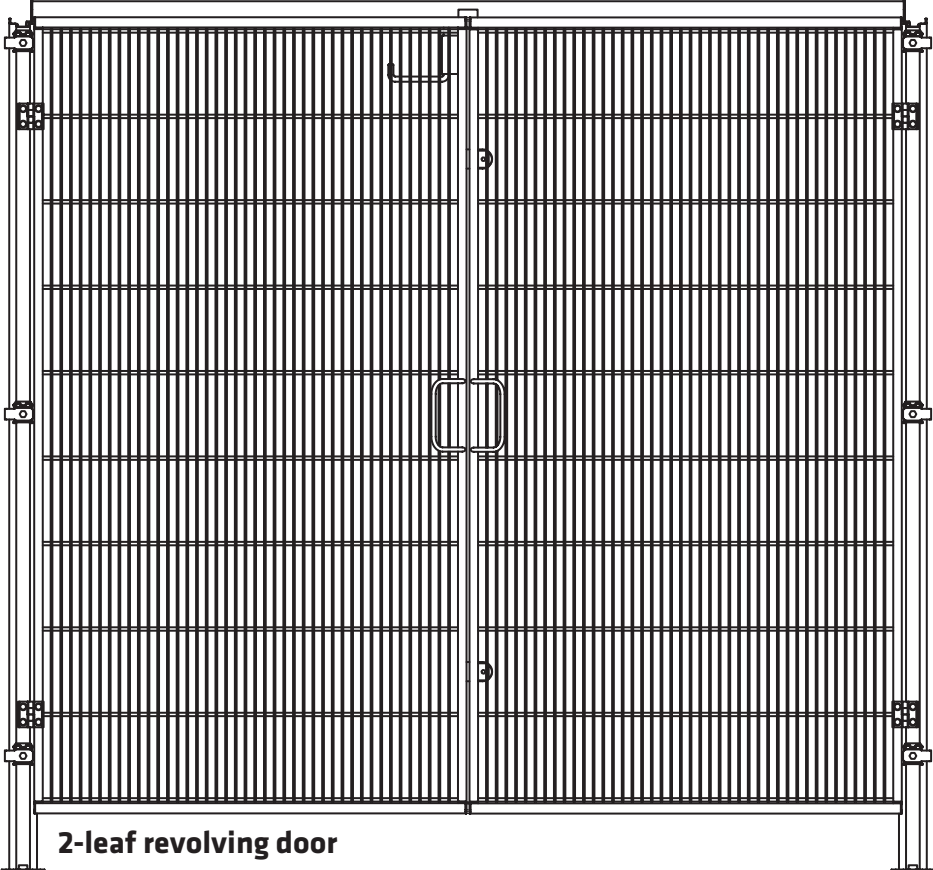
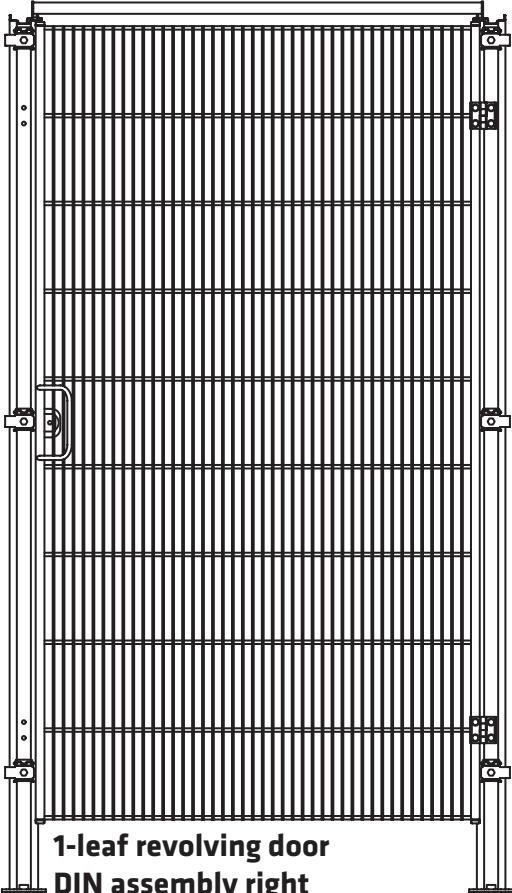
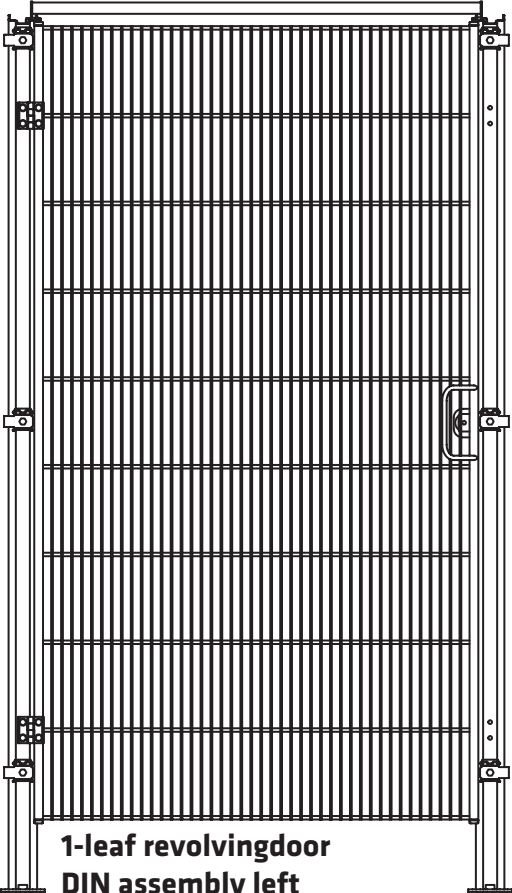

5.2. Assembly of doors | Assembled view

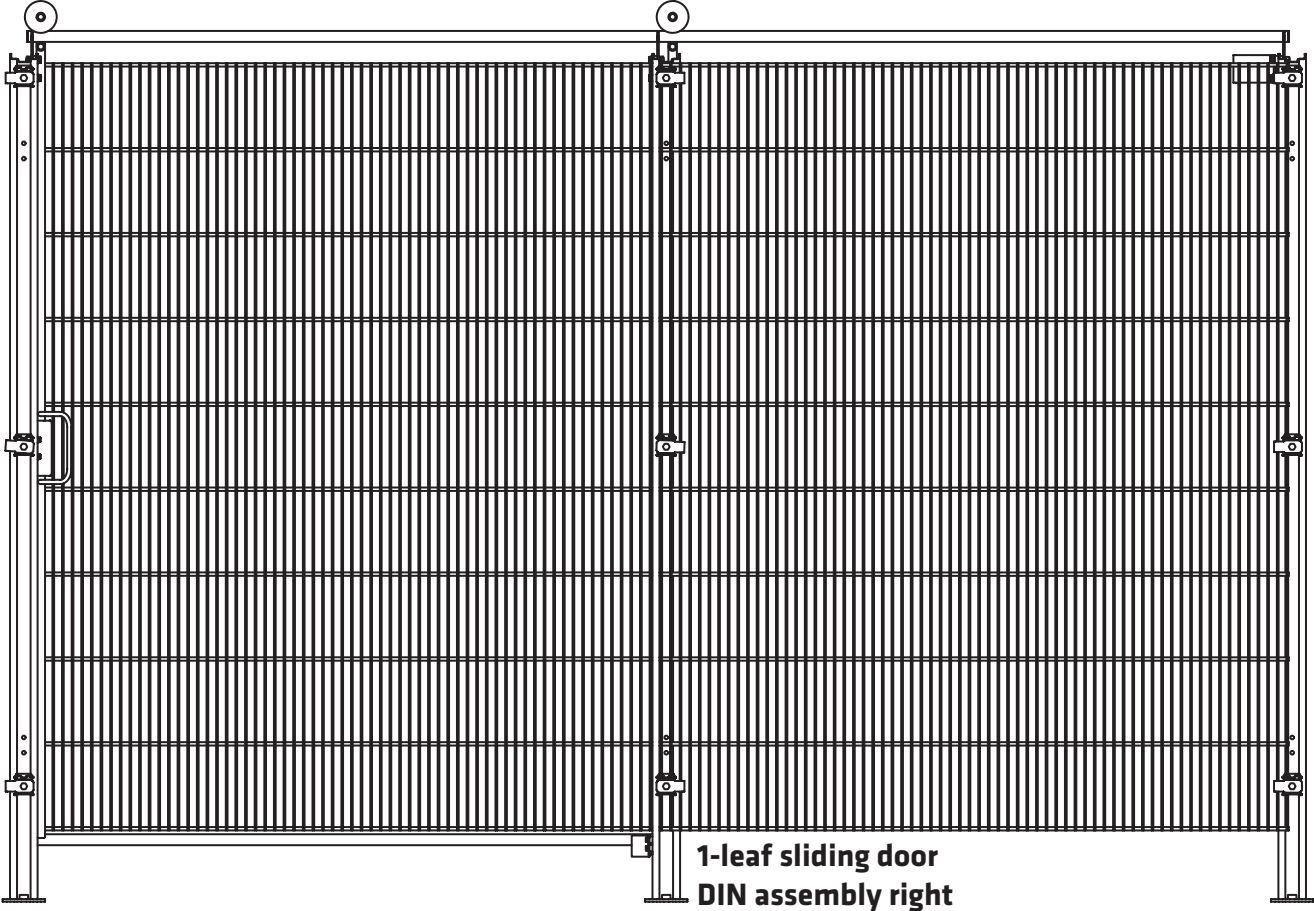
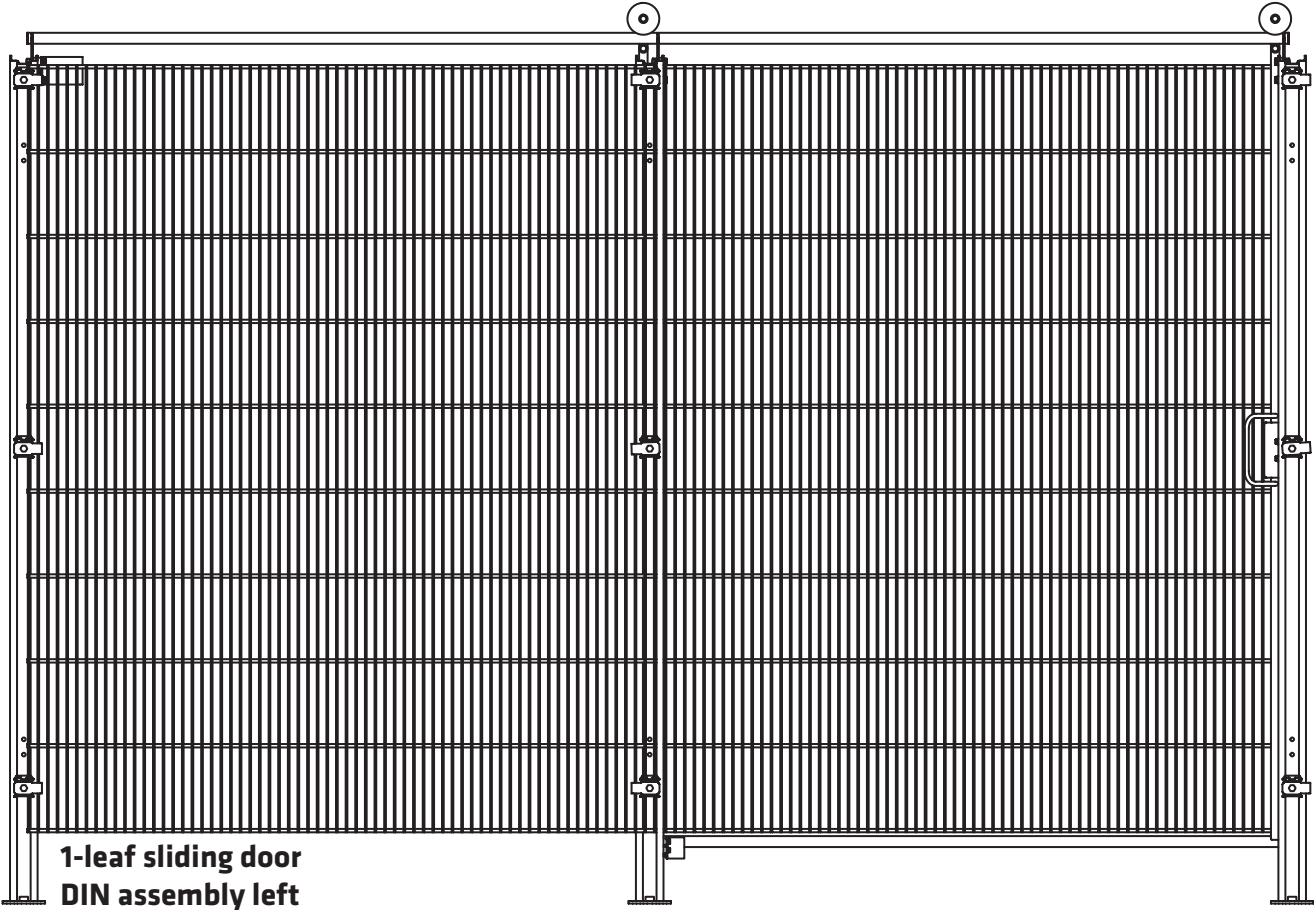

5.2.1. Assembly of 1-leaf revolving door | Order no. YUTLR18010019

DIN left assembly version

 2027 mm

 Refer to page 10

 **In case of left and right fence assembly, always ensure that only one vertical fence rod is in the clamping element**
(Refer to figures 1 and 2)

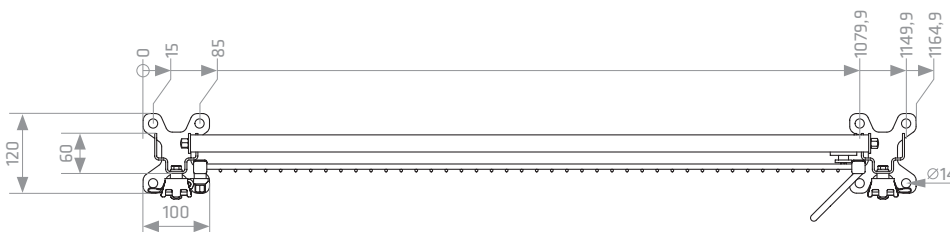
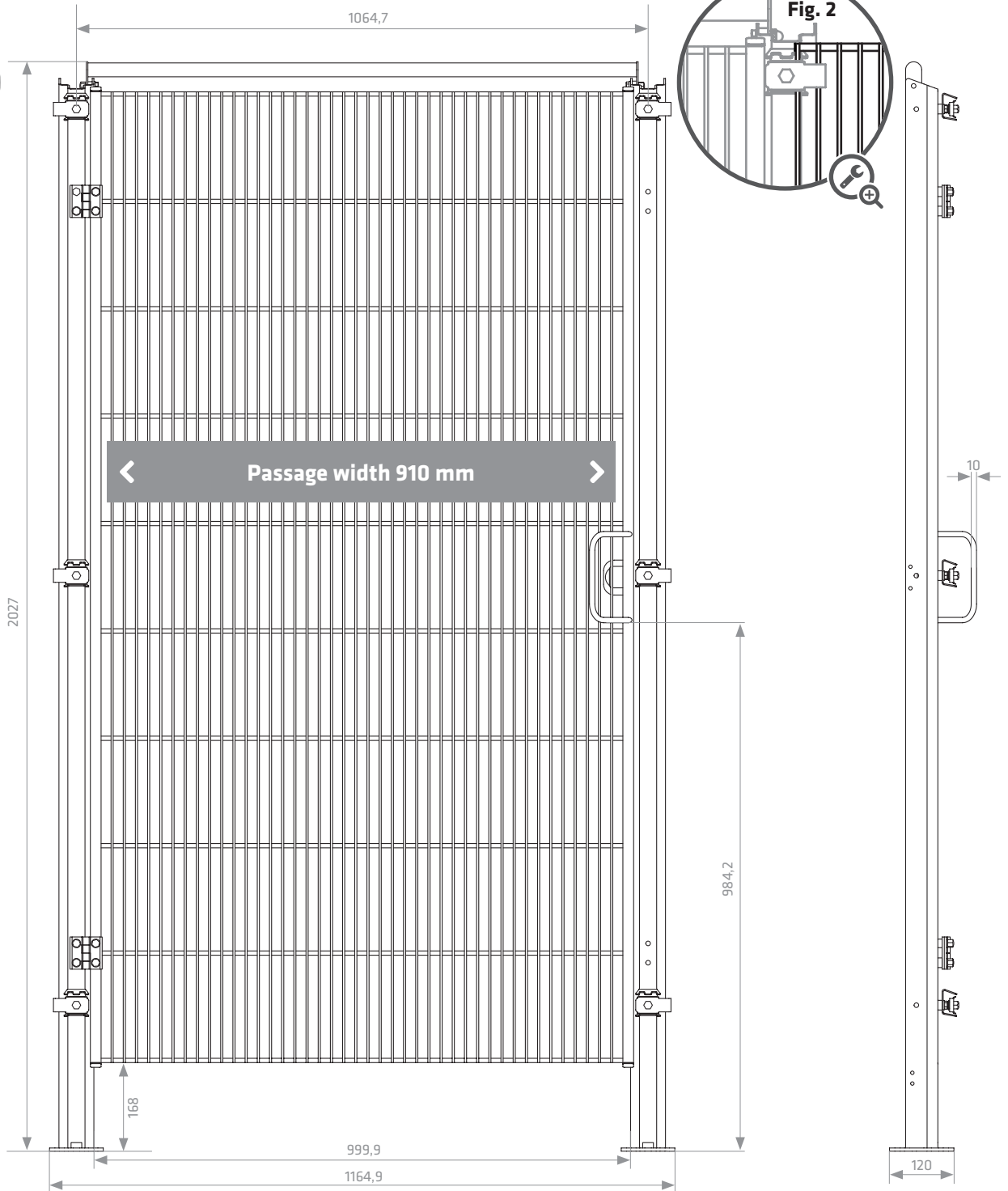
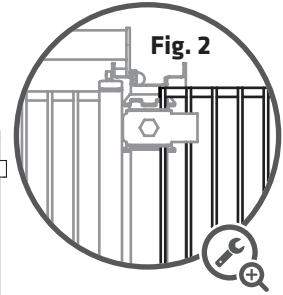
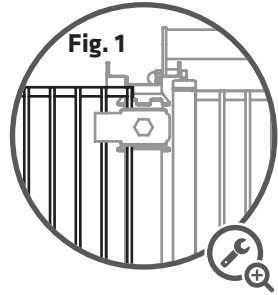
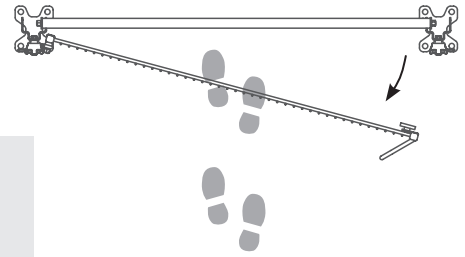

5.2.1. Assembly of 1-leaf revolving door | Order no. YUTLR18010019

DIN left assembly version

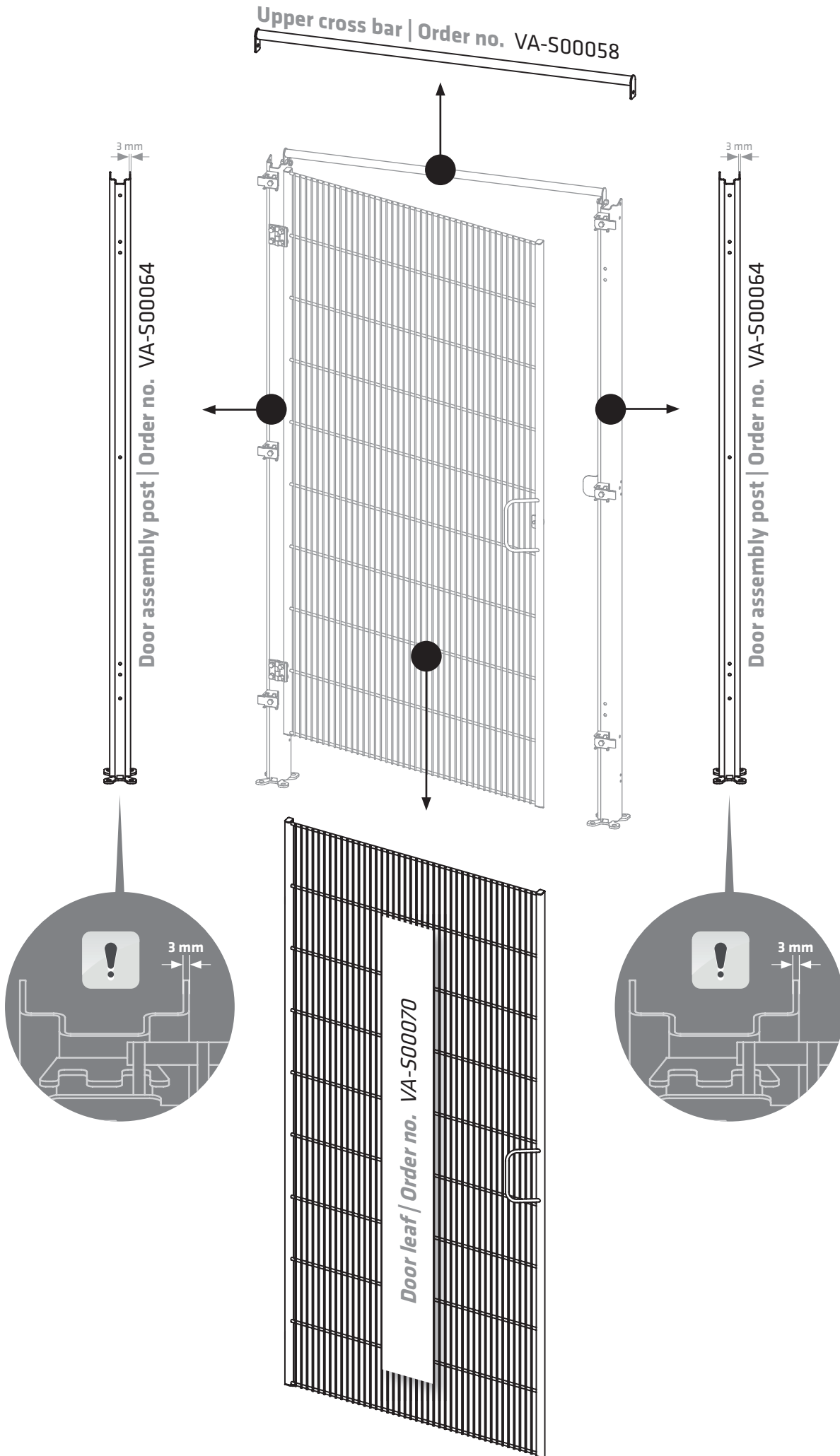

DIN left assembly version

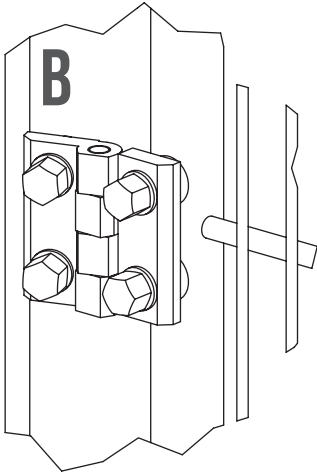
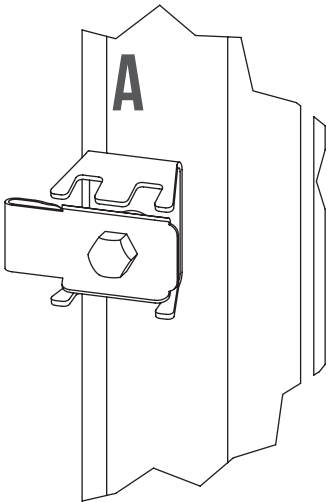
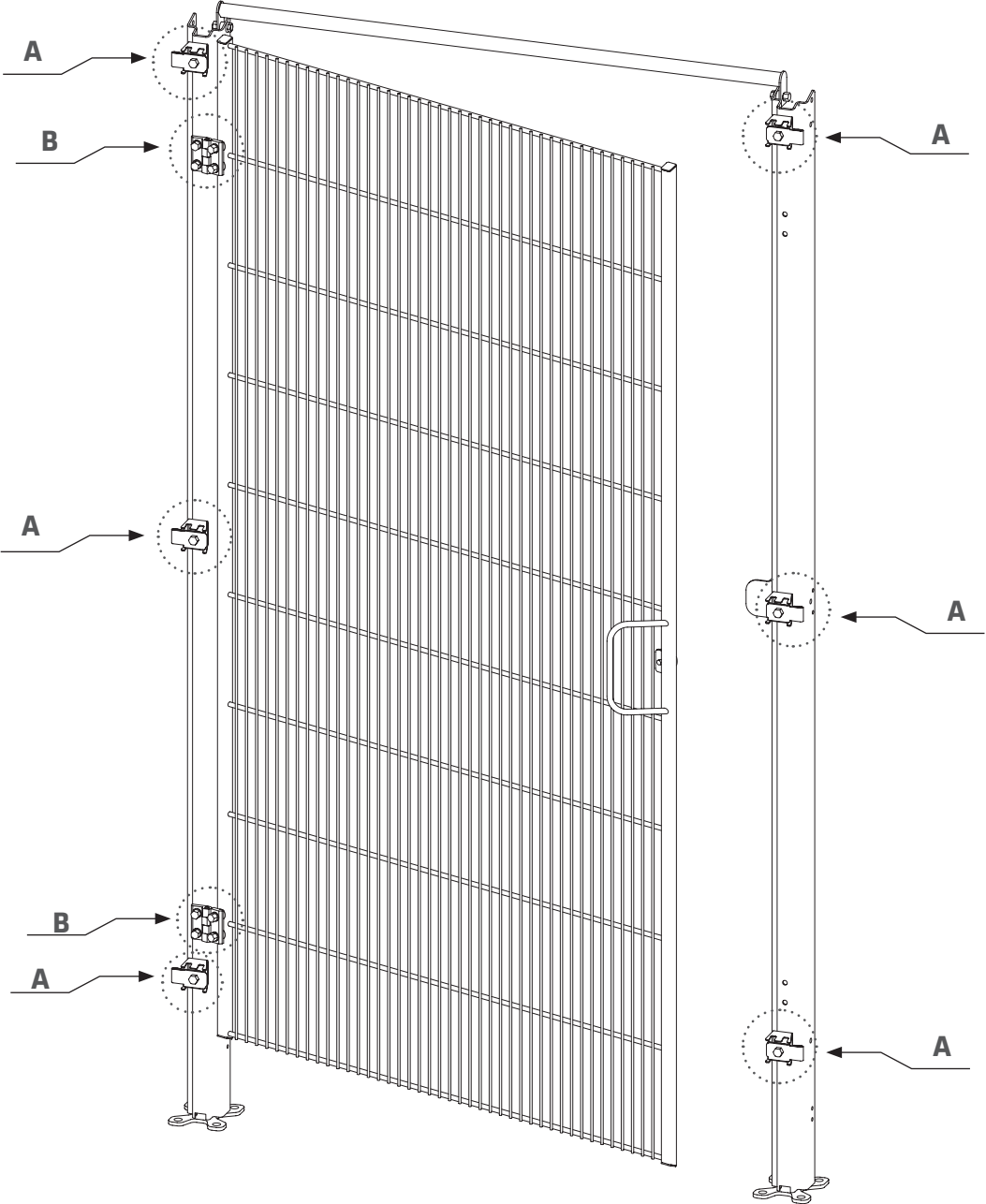

DIN left assembly version

2 x ZB31098

A

Rear view

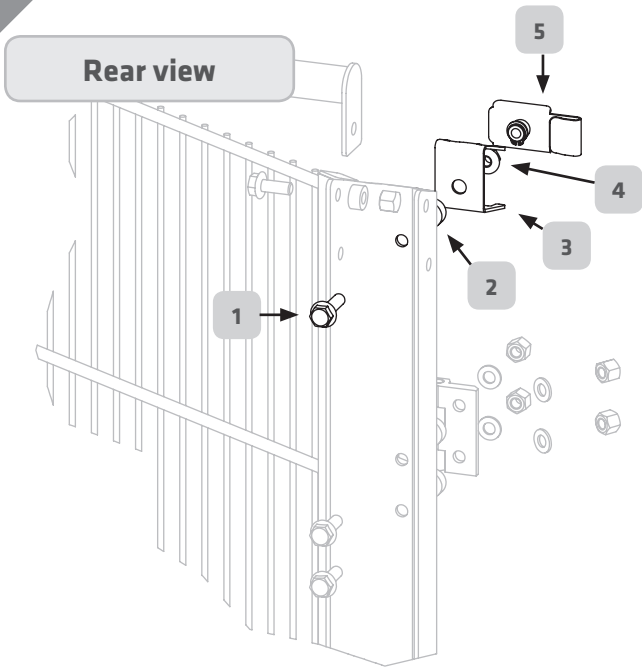

1 3 x DIN6921 A2 M8x30

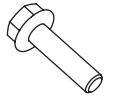

2 3 x VA-R 00031



3 3 x VA-B00030

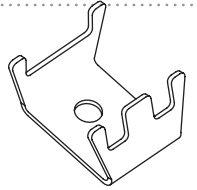

4 3 x DIN6923 A2 M8



5 3 x ZB31046

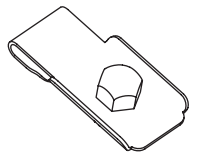

ZB31095

B

Rear view

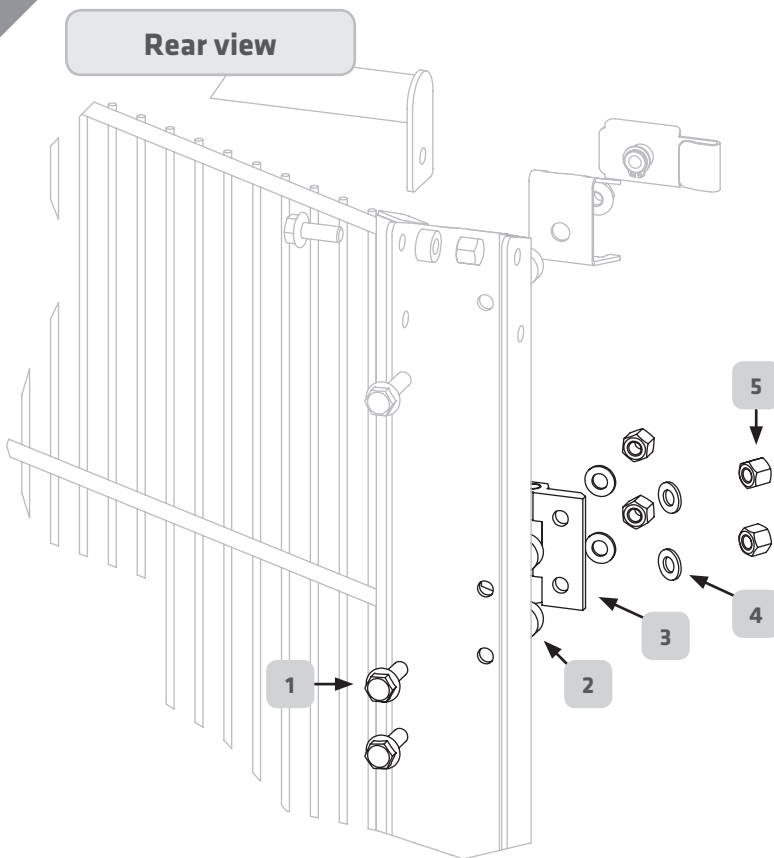

3 2 x ZB20022

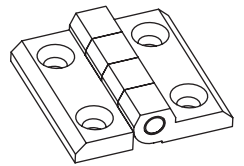

1 4 x DIN6921 A2 M8x25

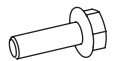

5 8 x DIN917 A2 M8



2 8 x VA-R 00031



4 8 x DIN125 A2 8,4

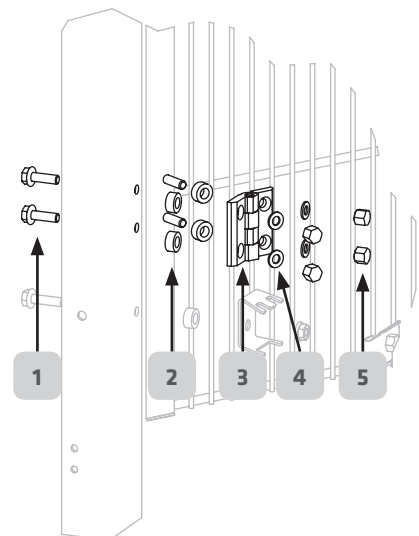

5.2.1. Assembly of 1-leaf revolving door | Order no. YUTLR18010019

DIN left assembly version

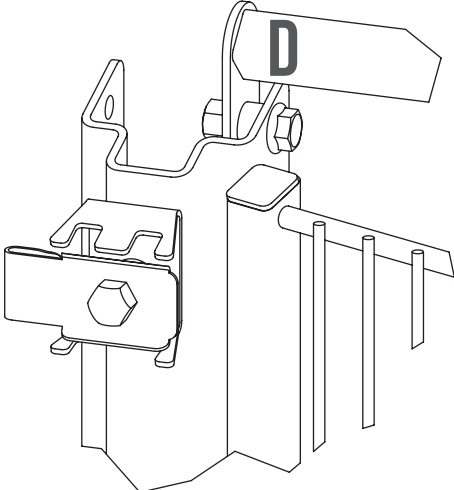
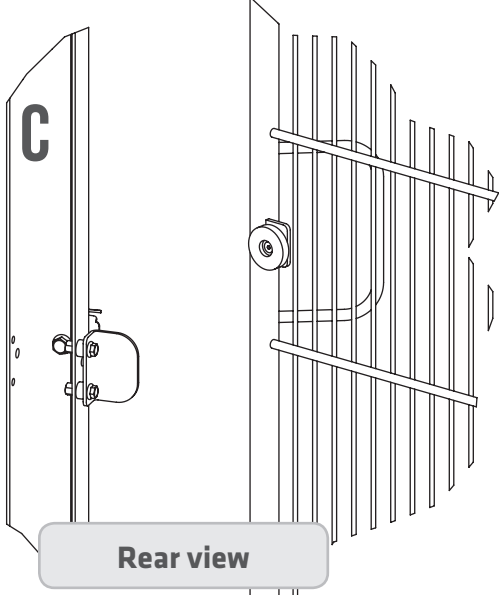
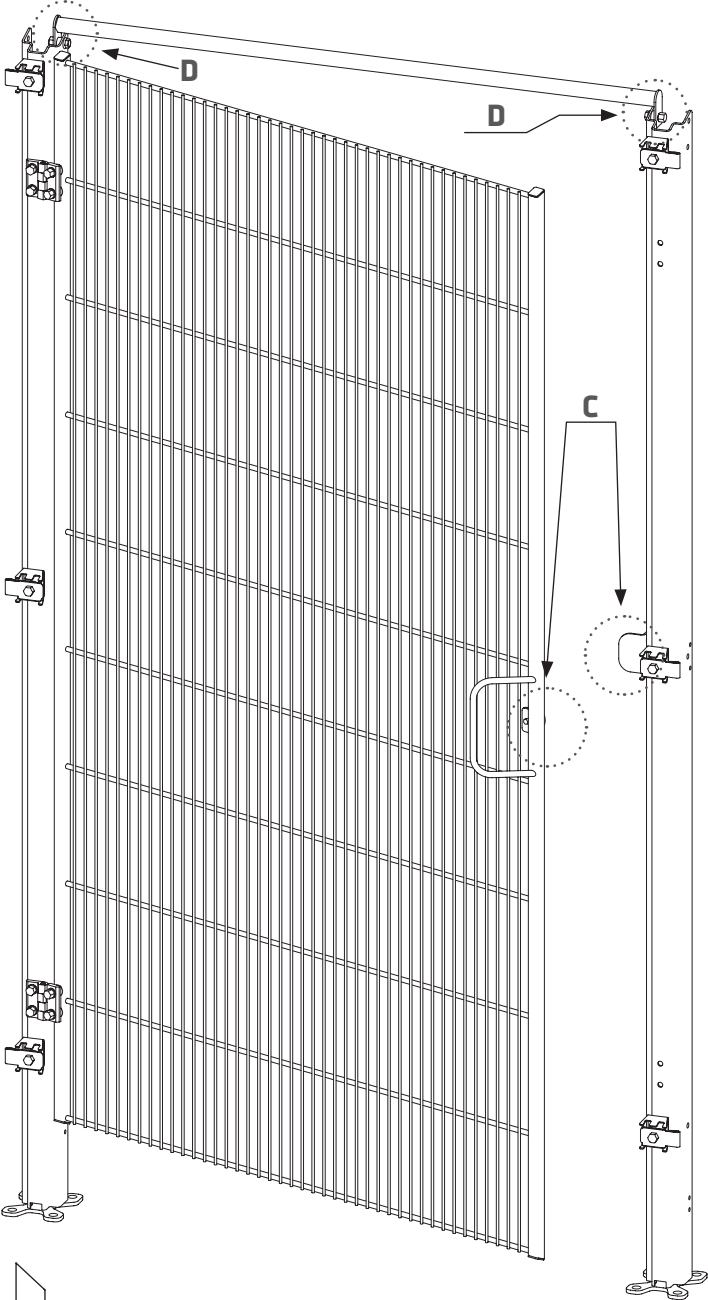

5.2.1. Assembly of 1-leaf revolving door | Order no. YUTLR18010019

DIN left assembly version

ZB31094

C

Rear view

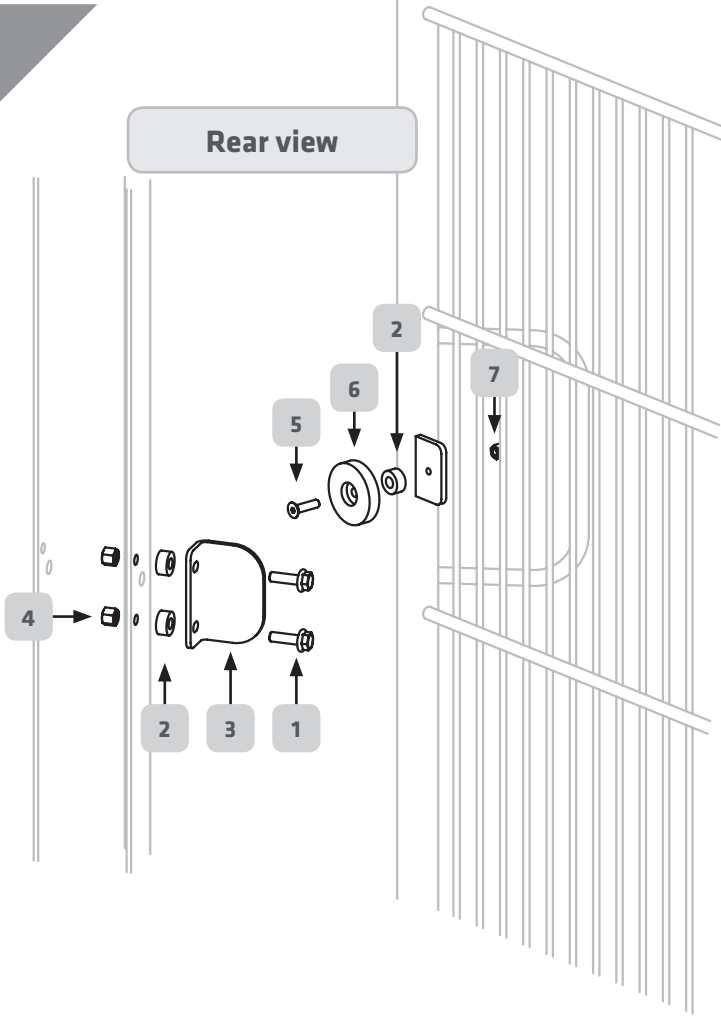

1 2 x DIN6921 A2 M6x16

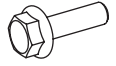

2 3 x VA-R 00055



3 1 x VA-B00093

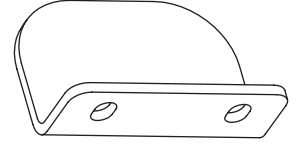

4 2 x DIN917 A2 M6



5 1 x DIN7991 A2 M5x20



6 1 x GN 50-45-HF-40

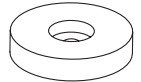

7 1 x DIN917 A2 M5



ZB31096

D

Rear view

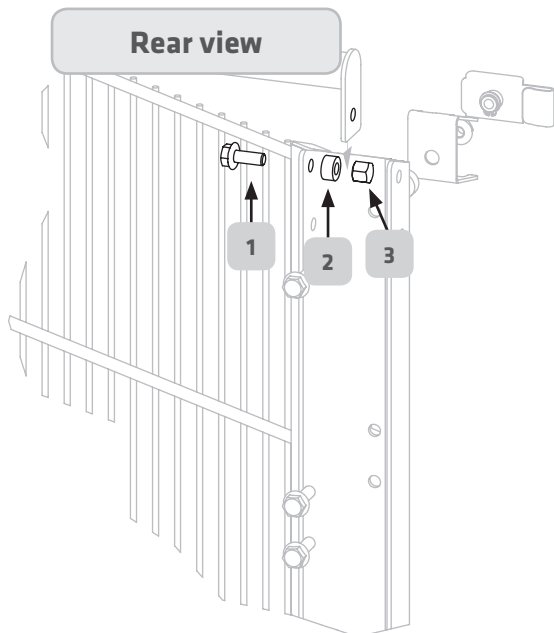

1 2 x DIN6921 A2 M8x20



2 2 x VA-R 00031



3 2 x DIN917 A2 M8



5.2.1. Assembly of 1-leaf revolving door | Order no. YUTLR18010019

DIN right assembly version



refer to page 10

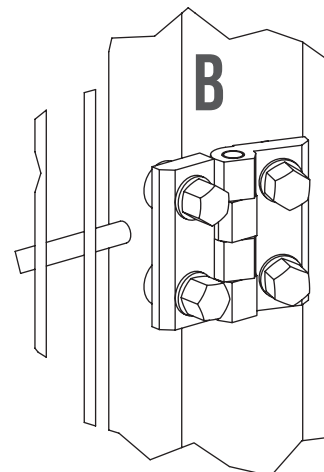
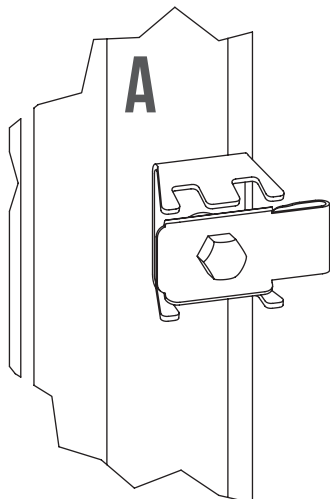
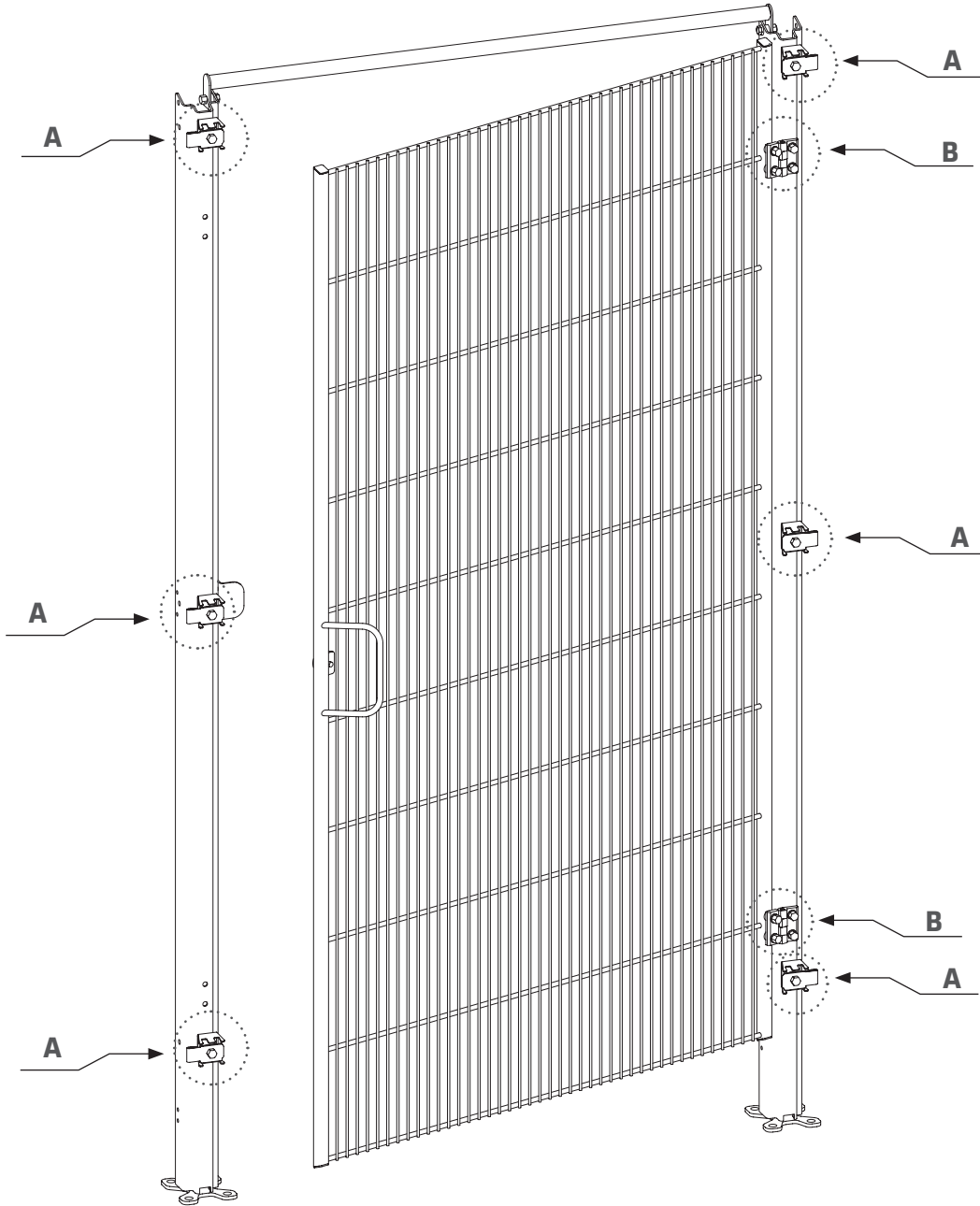
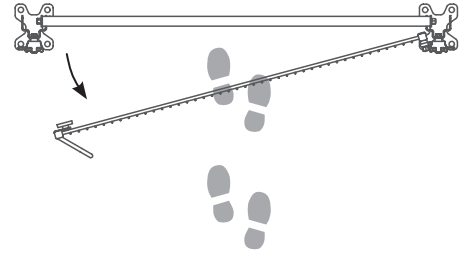

5.2.1. Assembly of 1-leaf revolving door | Order no. YUTLR18010019

DIN right assembly version

2 x ZB31098

A

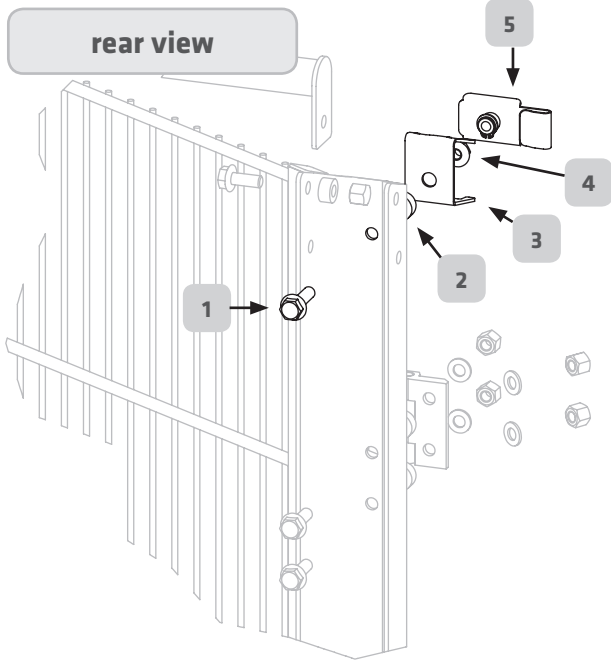

1 3 x DIN6921 A2 M8x30



2 3 x VA-R 00031



3 3 x VA-B00030

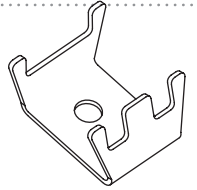

4 3 x DIN6923 A2 M8



5 3 x ZB31046

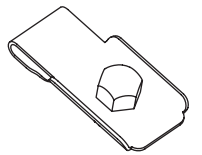

ZB31095

B

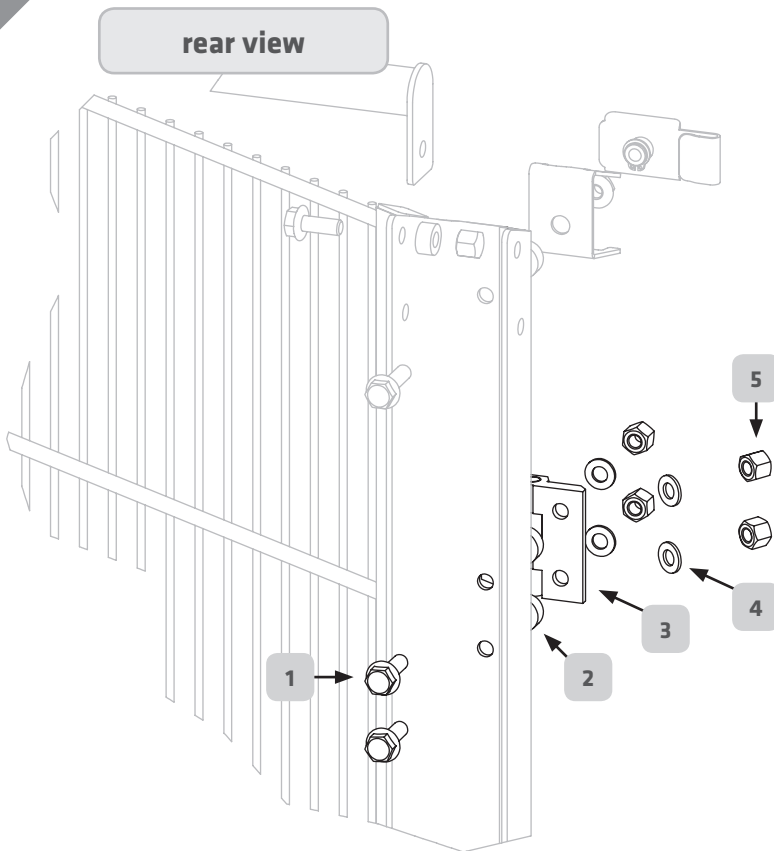

3 2 x ZB20022

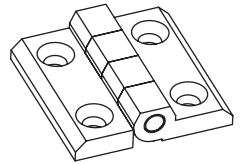

1 4 x DIN6921 A2 M8x25

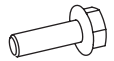

5 8 x DIN917 A2 M8



2 8 x VA-R 00031



4 8 x DIN125 A2 8,4

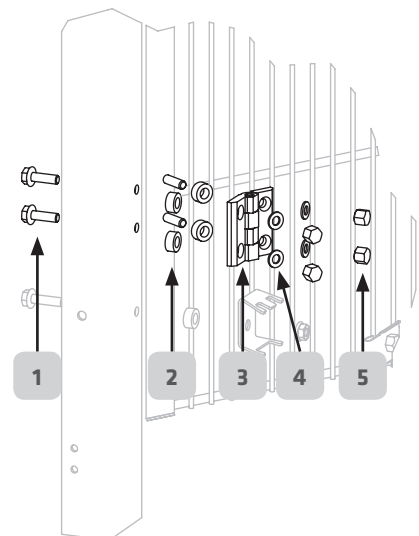

5.2.1. Assembly of 1-leaf revolving door | Order no. YUTLR18010019

DIN right assembly version

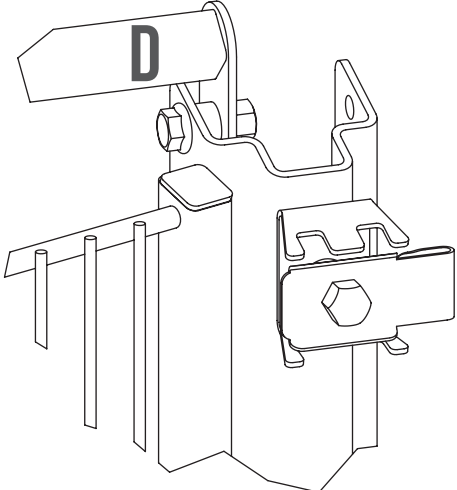
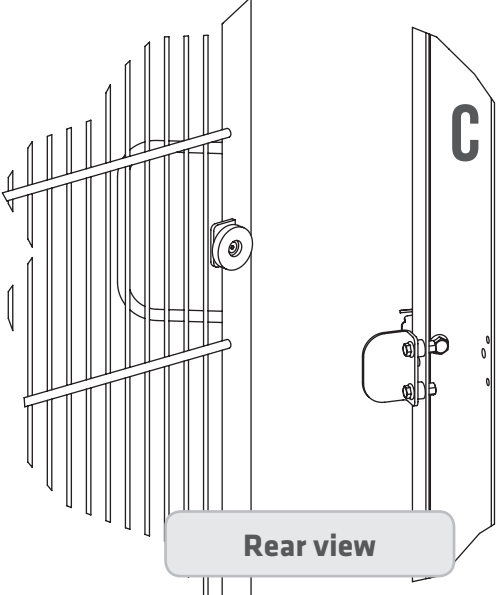
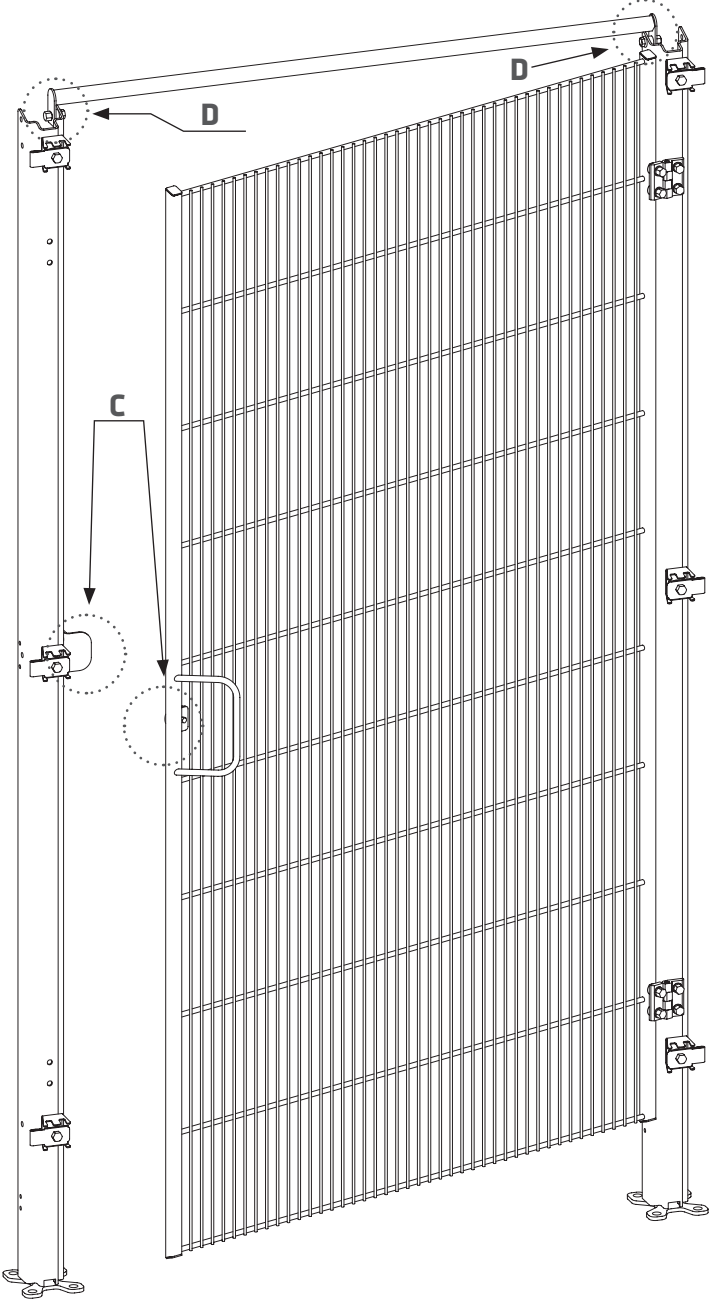

5.2.1. Assembly of 1-leaf revolving door | Order no. YUTLR18010019

DIN right assembly version

ZB31094

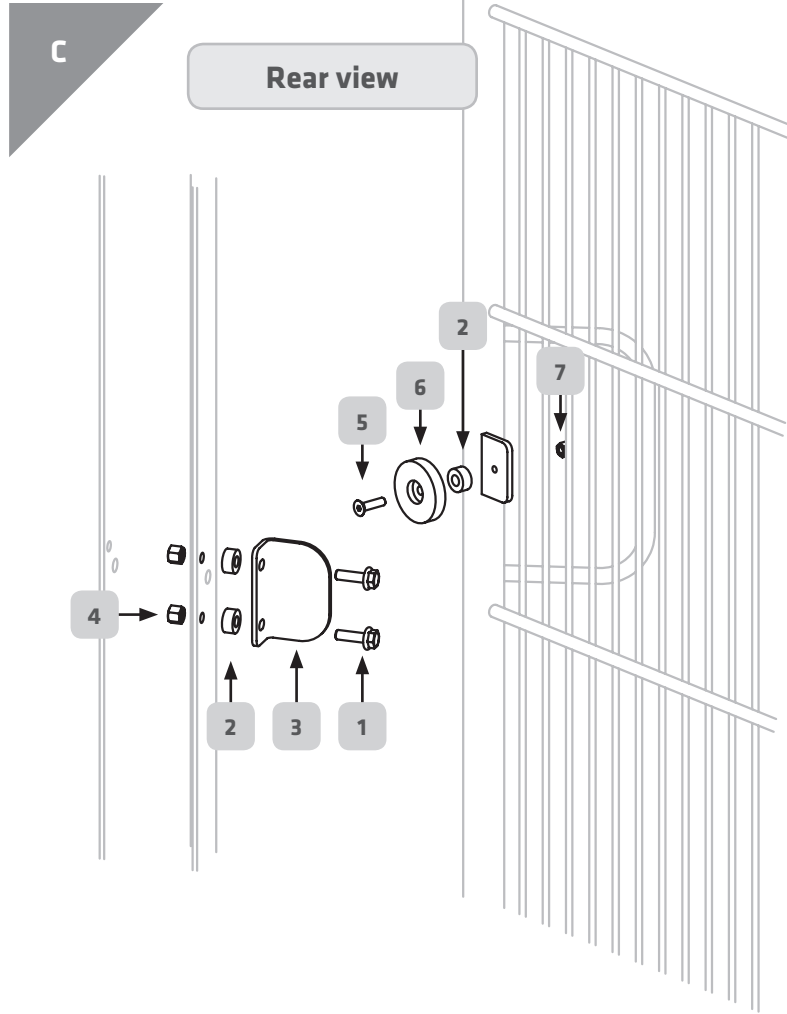

1 2 x DIN6921 A2 M6x16

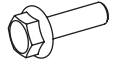

2 3 x VA-R 00055



3 1 x VA-B00093

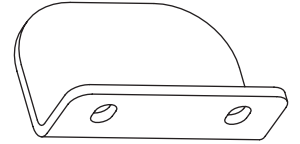

4 2 x DIN917 A2 M6



5 1 x DIN7991 A2 M5x20



6 1 x GN 50-45-HF-40

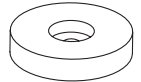

7 1 x DIN917 A2 M5



ZB31096

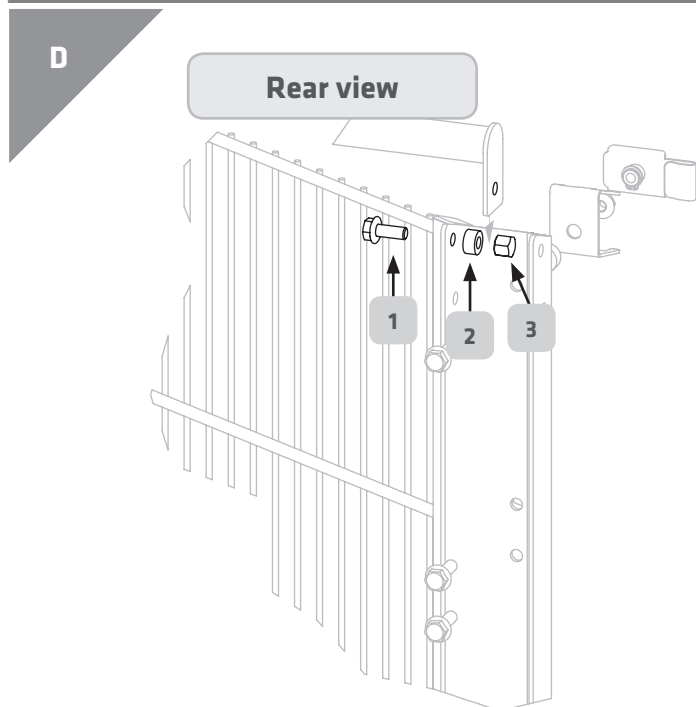

1 2 x DIN6921 A2 M8x20



2 2 x VA-R 00031



3 2 x DIN917 A2 M8



5.2.2. Assembly of 2-leaf revolving door | Order no. YUDT18020019



2039 mm



Refer to page 10

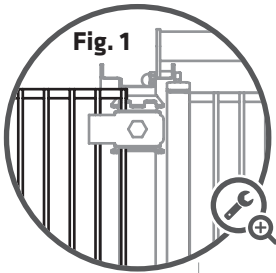
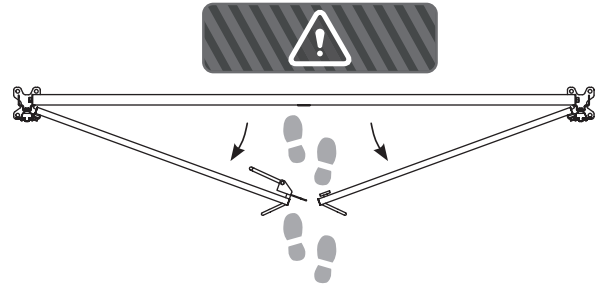
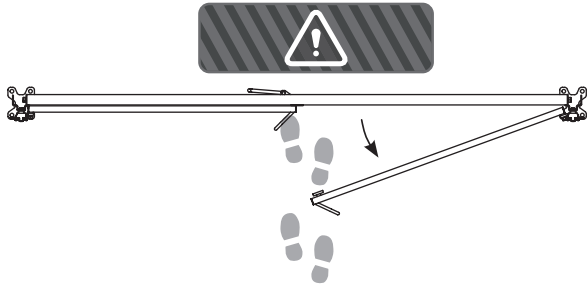

Fig. 1

In case of left and right fence assembly, always ensure that only one vertical fence rod is in the clamping element.
(Refer to figures 1 and 2)

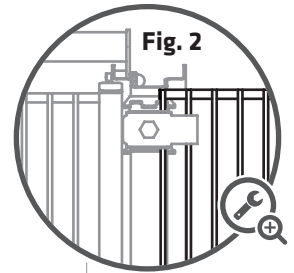
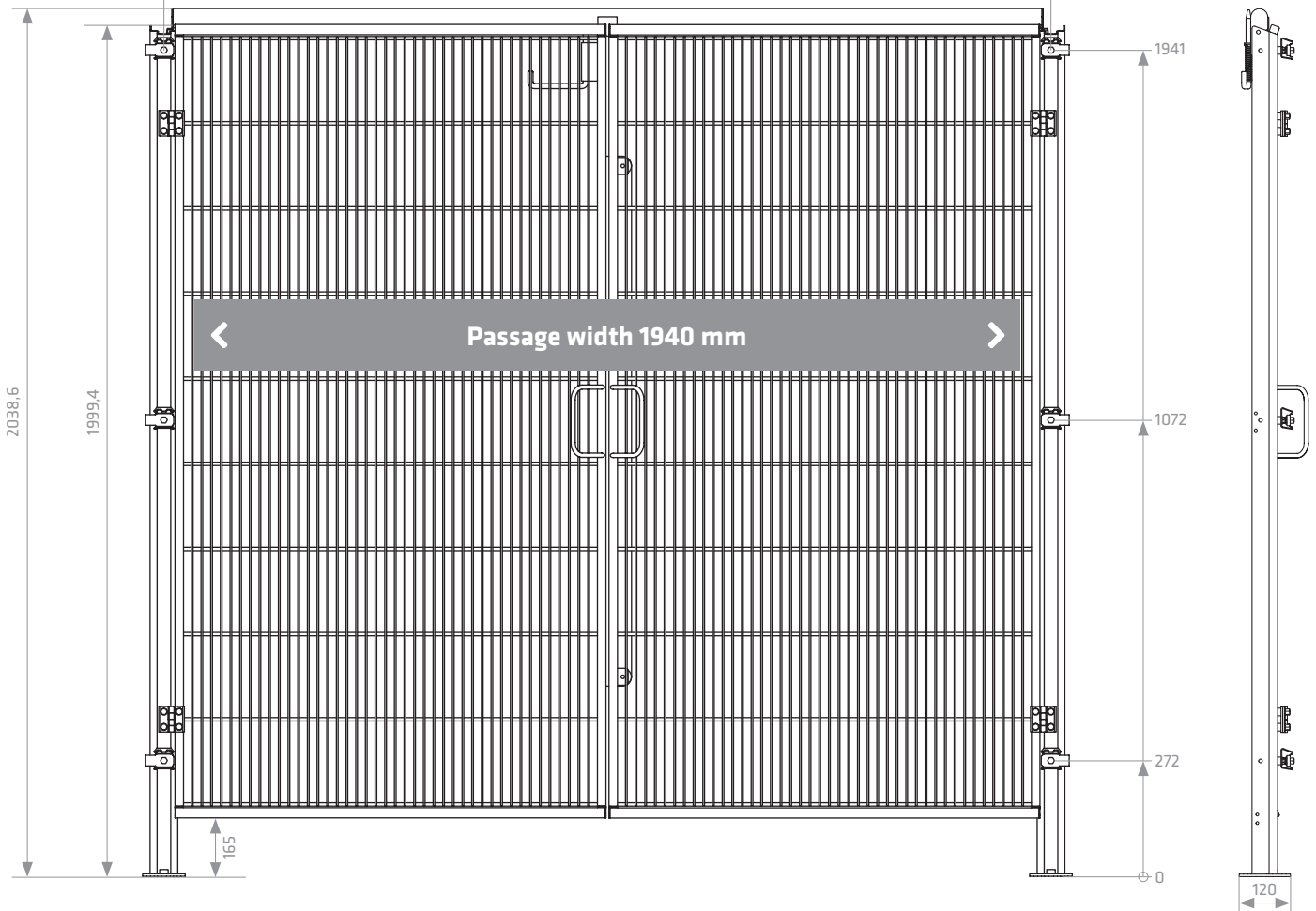
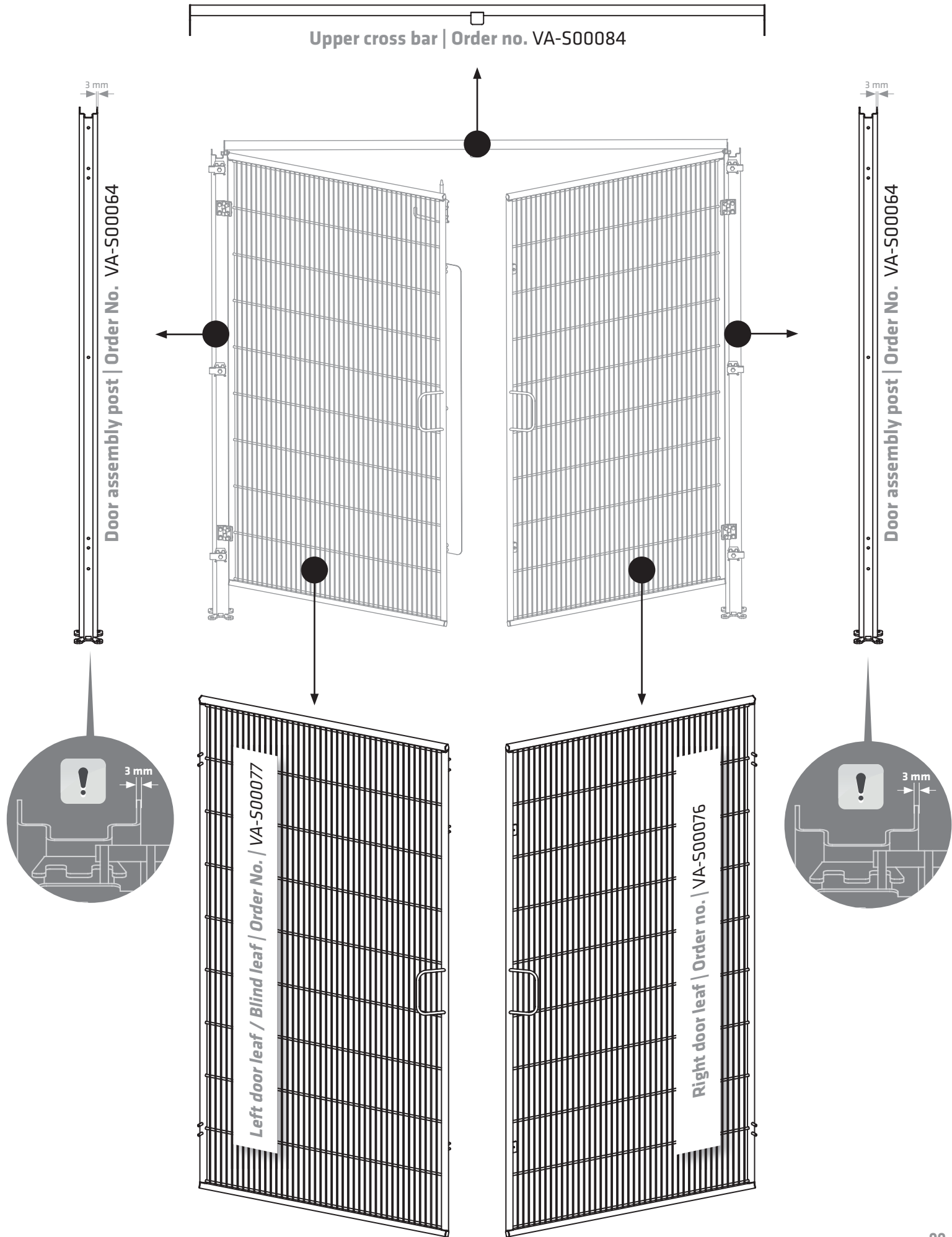

Fig. 2

2083,2



5.2.2. Assembly of 2-leaf revolving door | Order no. YUDT18020019



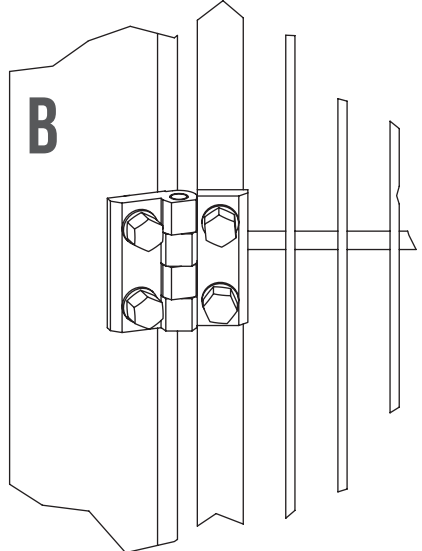
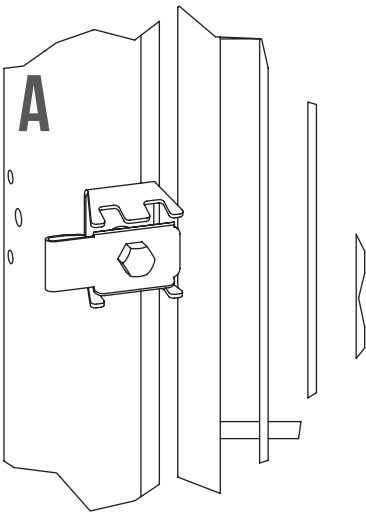
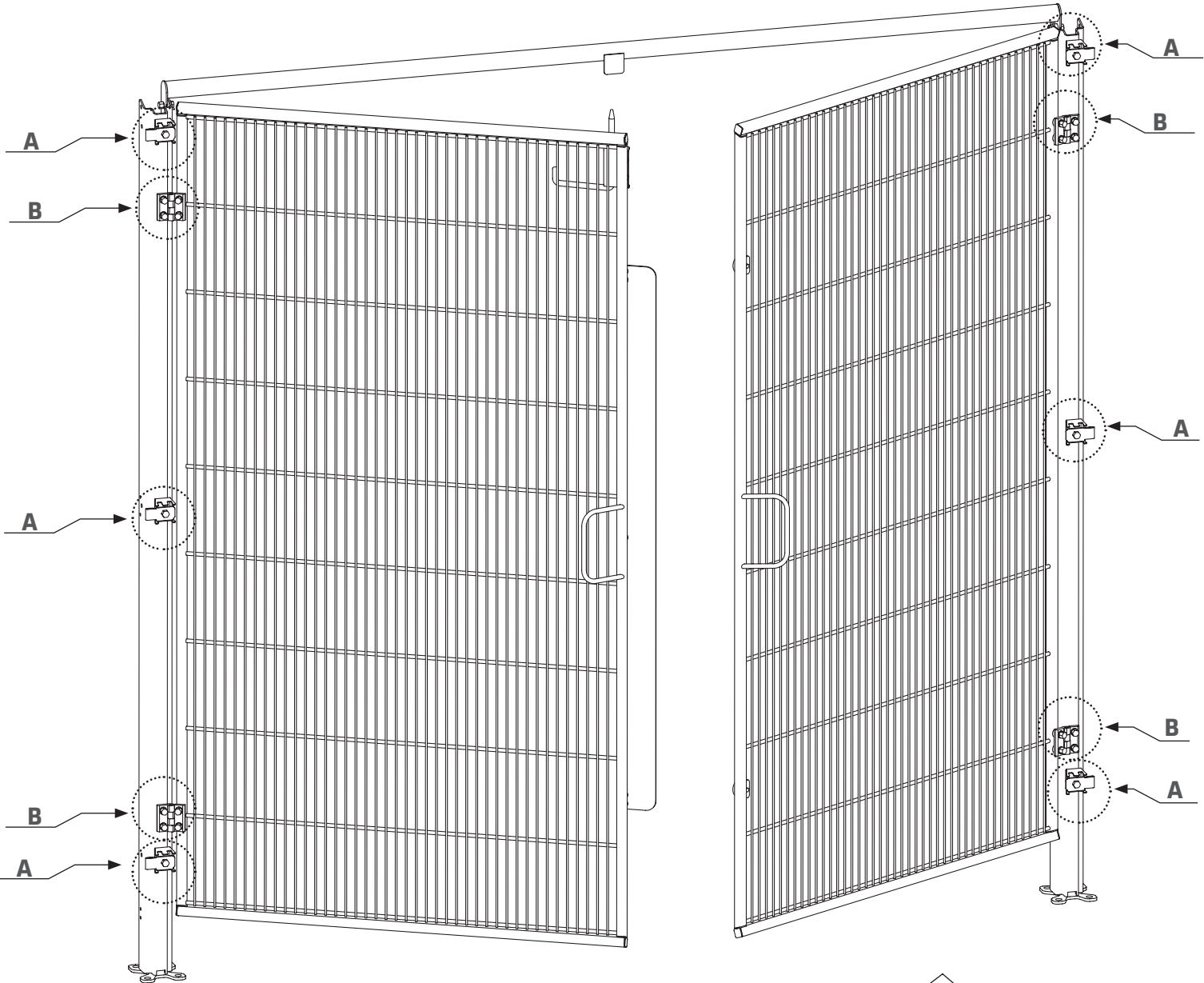

2 x ZB31098

A

Rear view

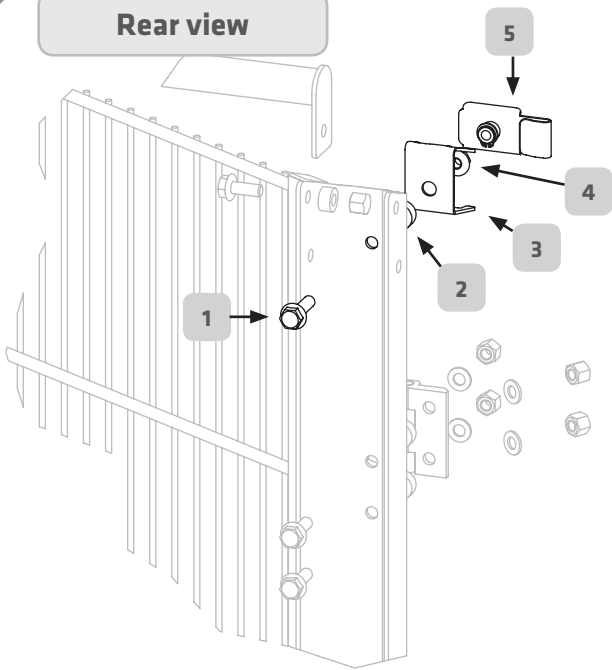

1 3 x DIN6921 A2 M8x30



2 3 x VA-R 00031



3 3 x VA-B00030

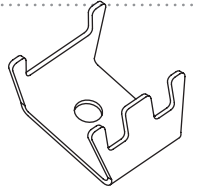

4 3 x DIN6923 A2 M8



5 3 x ZB31046

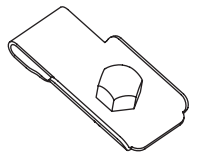

2 x ZB31095

B

Rear view

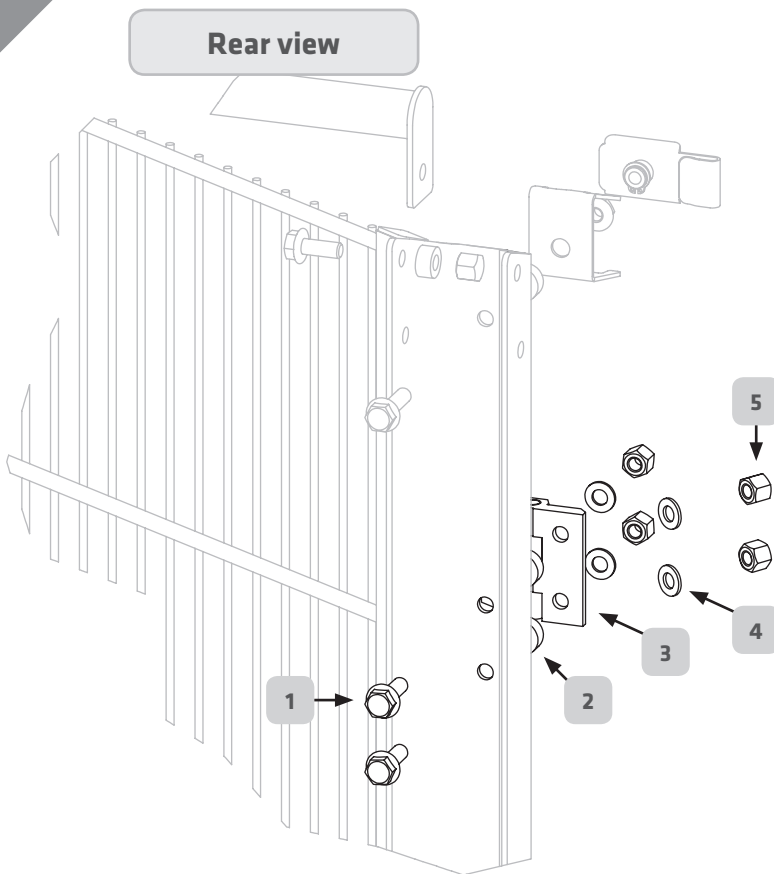

3 2 x ZB20022

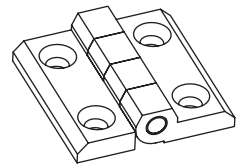

1 4 x DIN6921 A2 M8x25

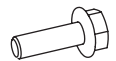

5 8 x DIN917 A2 M8



2 8 x VA-R 00031



4 8 x DIN125 A2 8,4

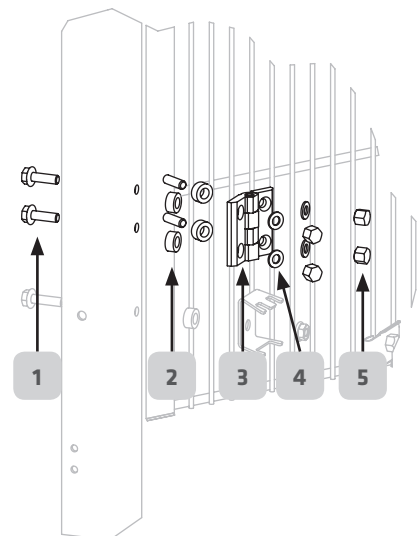

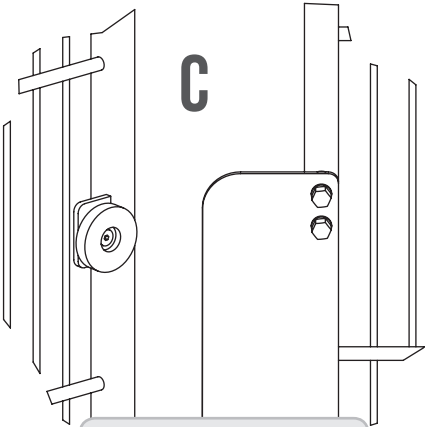
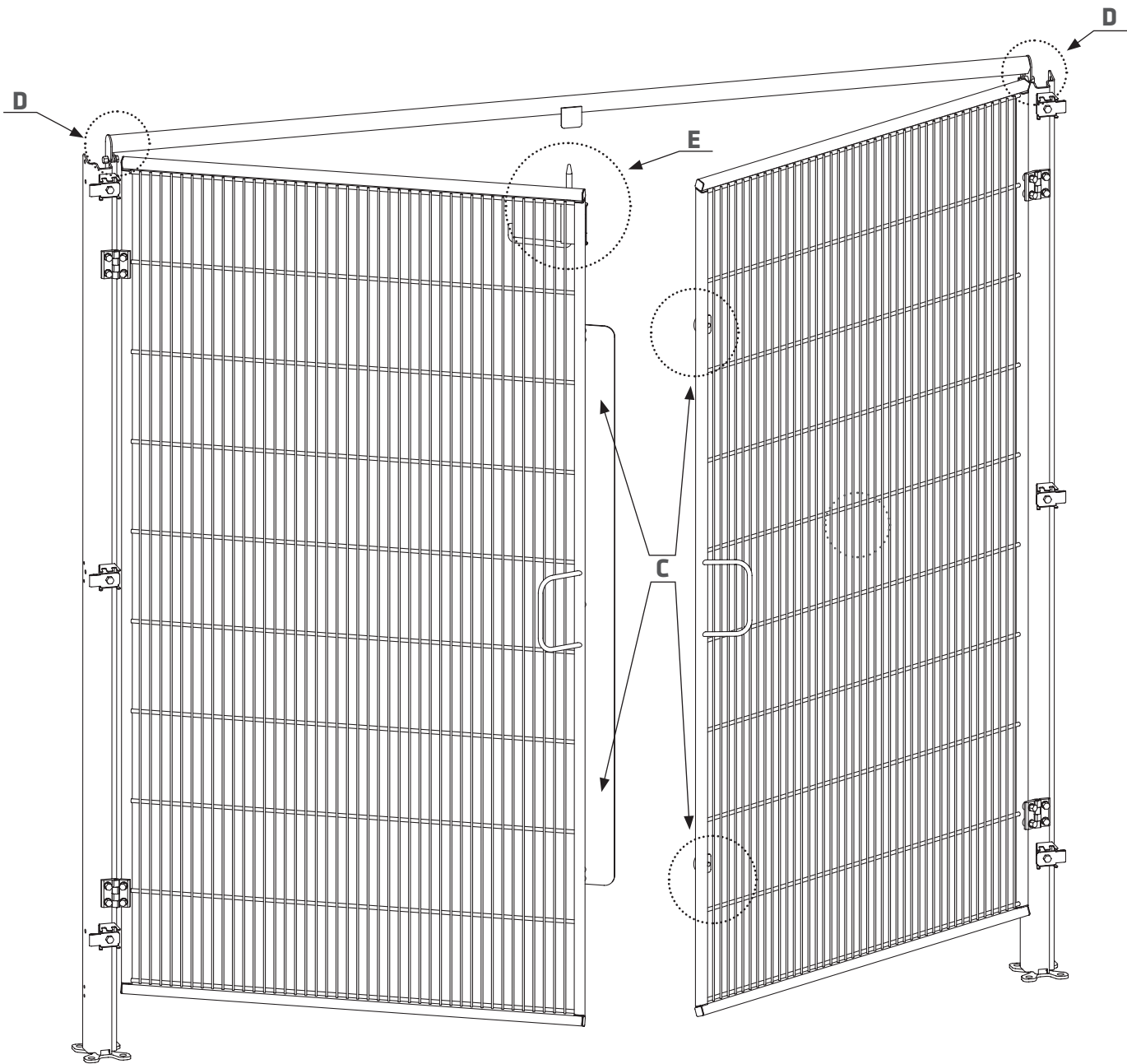

Rear view

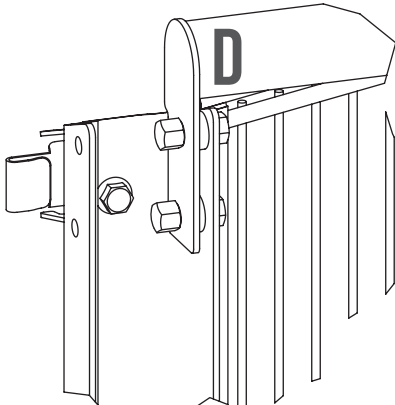



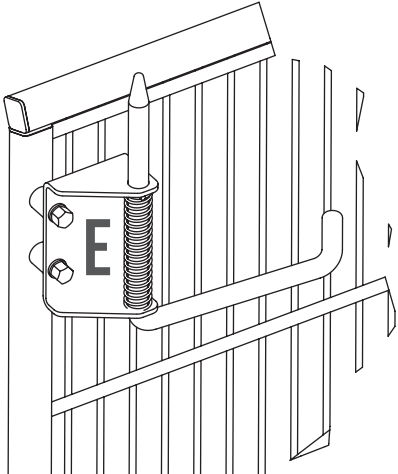



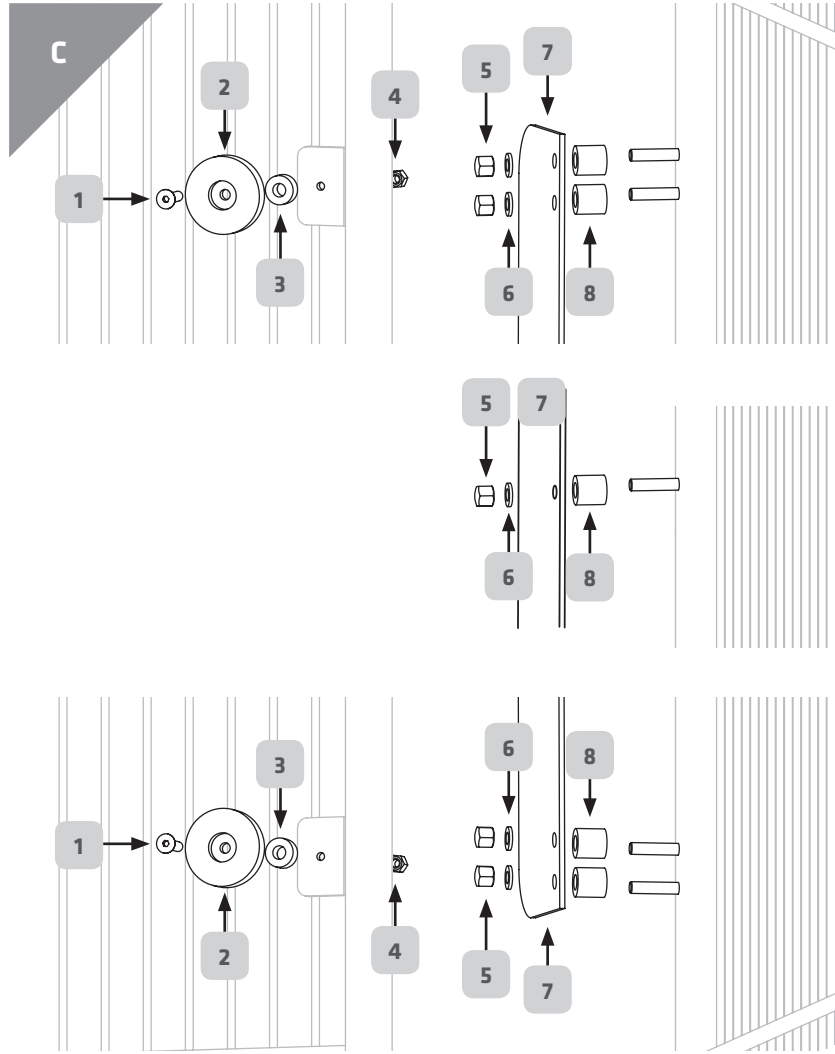

Rear view

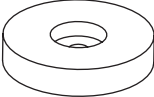

Rear view

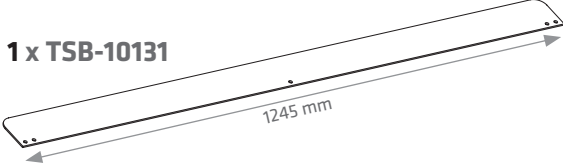

ZB31116



| | | |
|---|-----------------------|---|
| 1 | 2 x DIN7991 A2 M5x20 |  |
| 2 | 2 x GN 50-45-HF-40 |  |
| 3 | 2 x VA-R 00055 |  |
| 4 | 2 x DIN917 A2 M5 |  |
| 5 | 5 x DIN917 A2 M6 |  |
| 6 | 5 x DIN125 - A2 A 6.4 |  |
| 7 | 1 x TSB-10131 |  |
| 8 | 5 x VA-R 00047 |  |

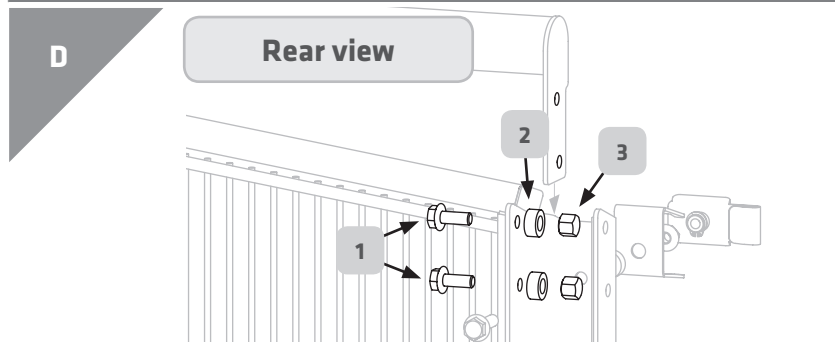

2 x ZB31096

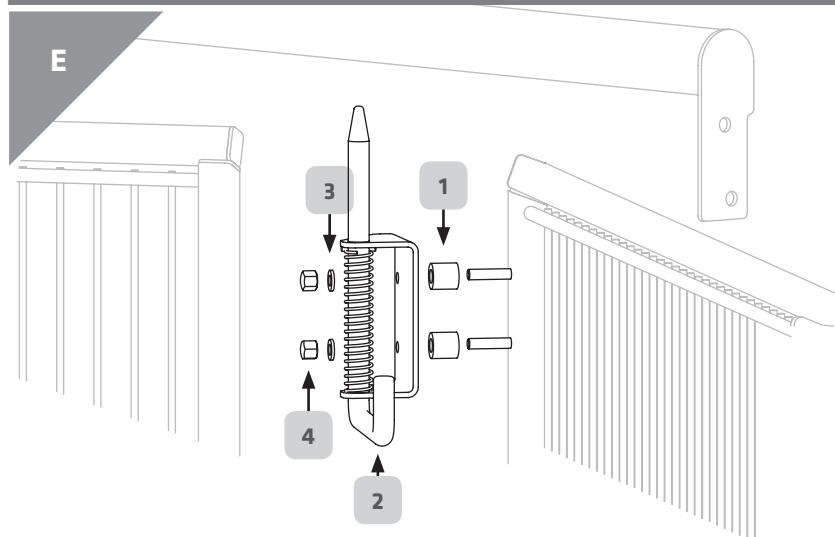

| | | |
|---|----------------------|---|
| 1 | 2 x DIN6921 A2 M8x20 |  |
| 2 | 2 x VA-R 00031 |  |
| 3 | 2 x DIN917 A2 M8 |  |

ZB31117

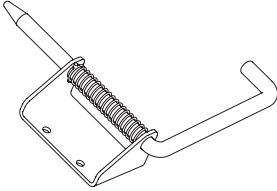

| | | |
|---|---------------------|---|
| 1 | 2 x VA-R00047 |  |
| 2 | 1 x ZB20033 |  |
| 3 | 2 x DIN 125 - A 6.4 |  |
| 4 | 2 x DIN917 A2-M6 |  |

5.2.3. Assembly of 1-leaf sliding door | Order no. YUSTL18015019



DIN left assembly version

 2039 mm



Refer to page 10



When assembling the fence, always ensure that the correct number of vertical fence rods are in the clamping element.
(Refer to figures 1, 2 and 3)

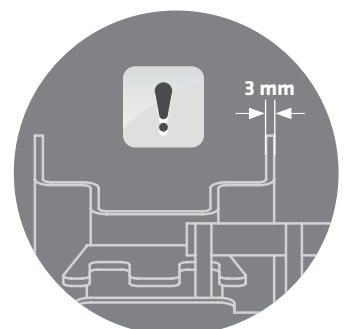
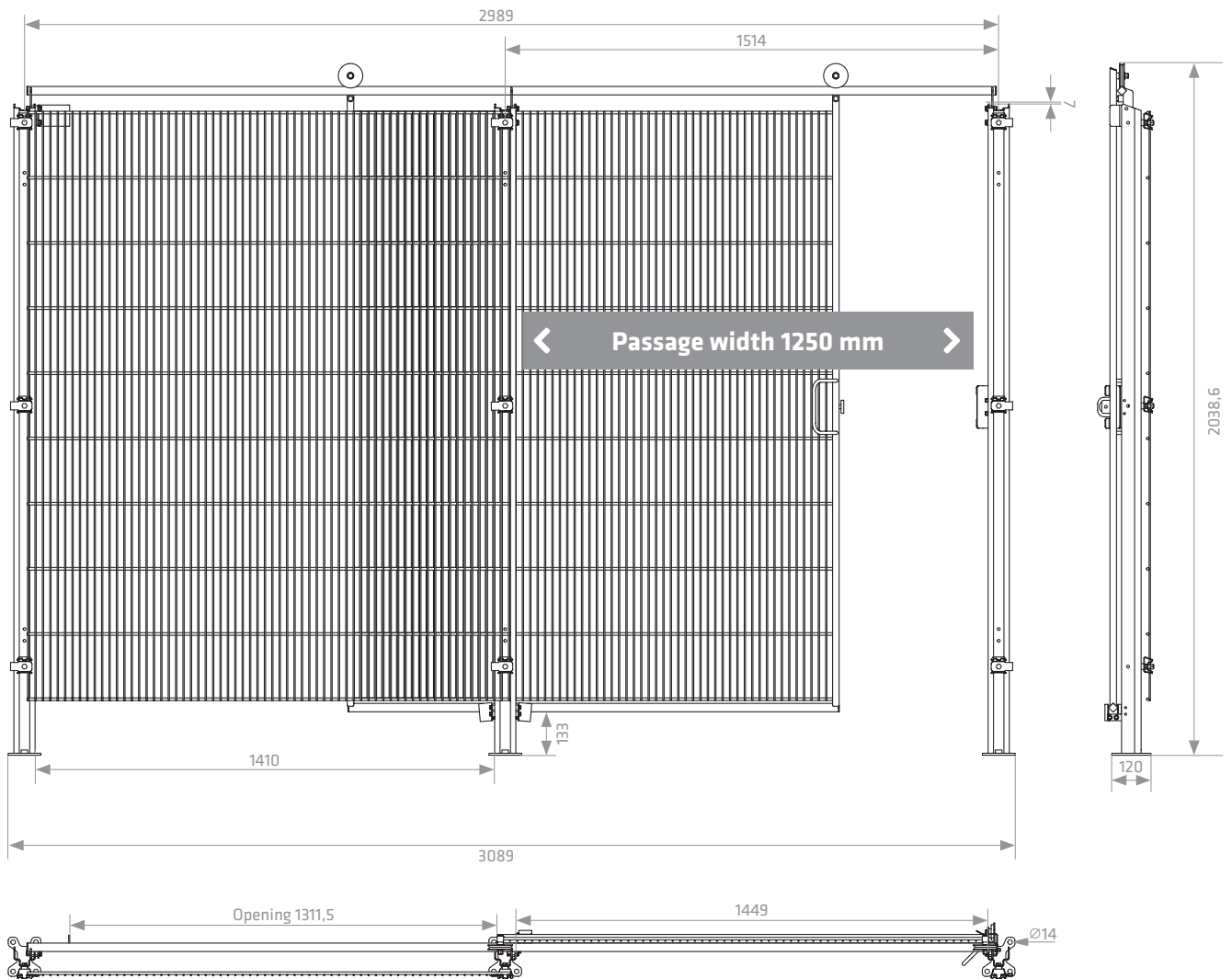
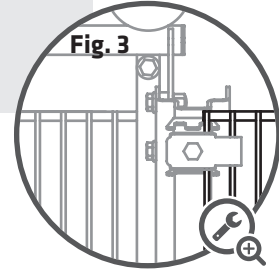
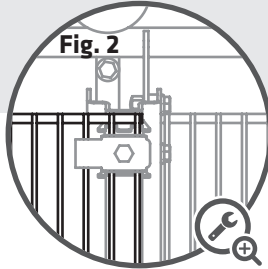
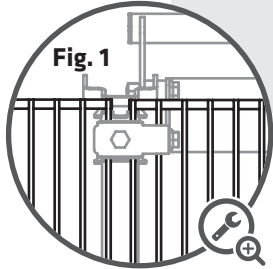

5.2.3. Assembly of 1-leaf sliding door | Order no. YUSTL18015019

DIN left assembly version

Upper cross bar | Order no. VA-S00074

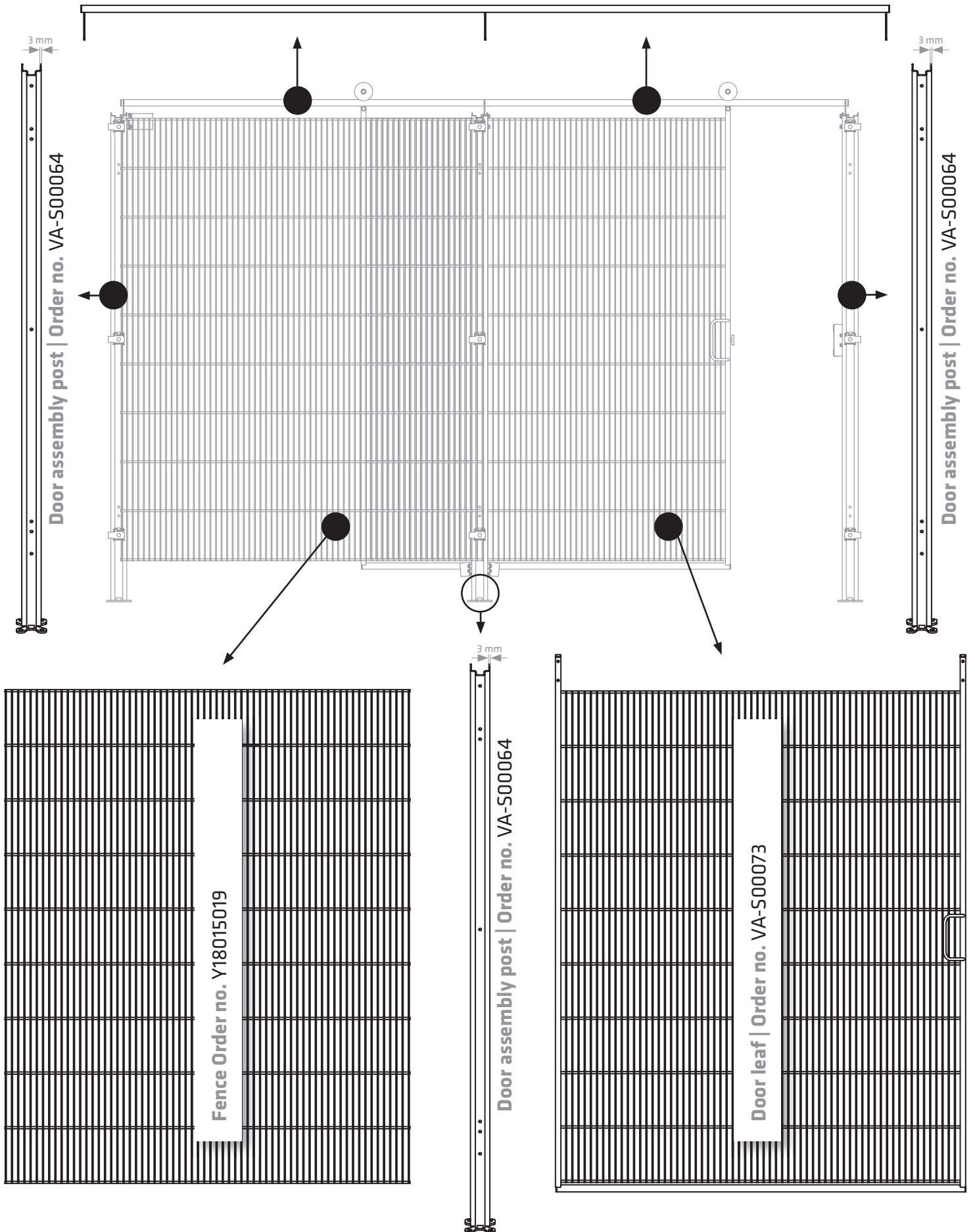

DIN left assembly version

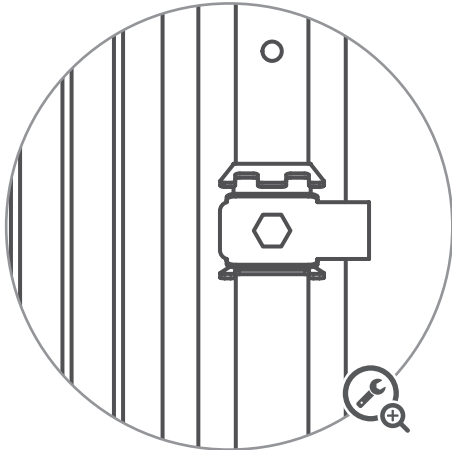
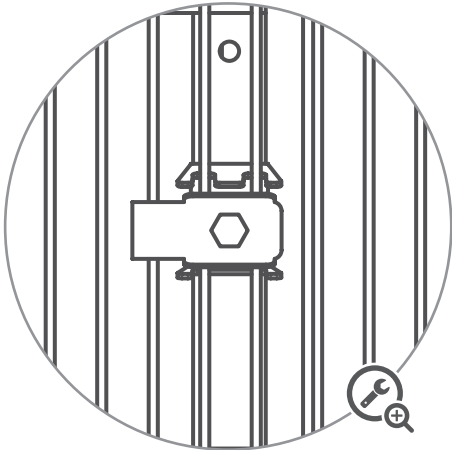
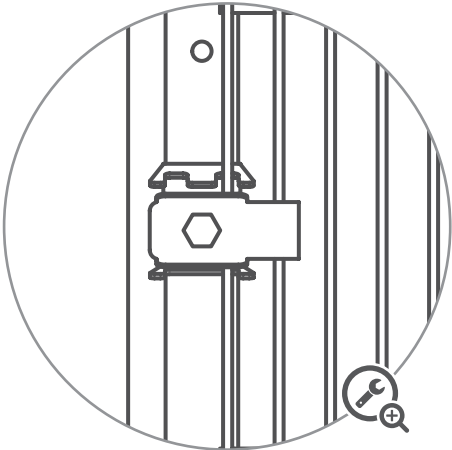
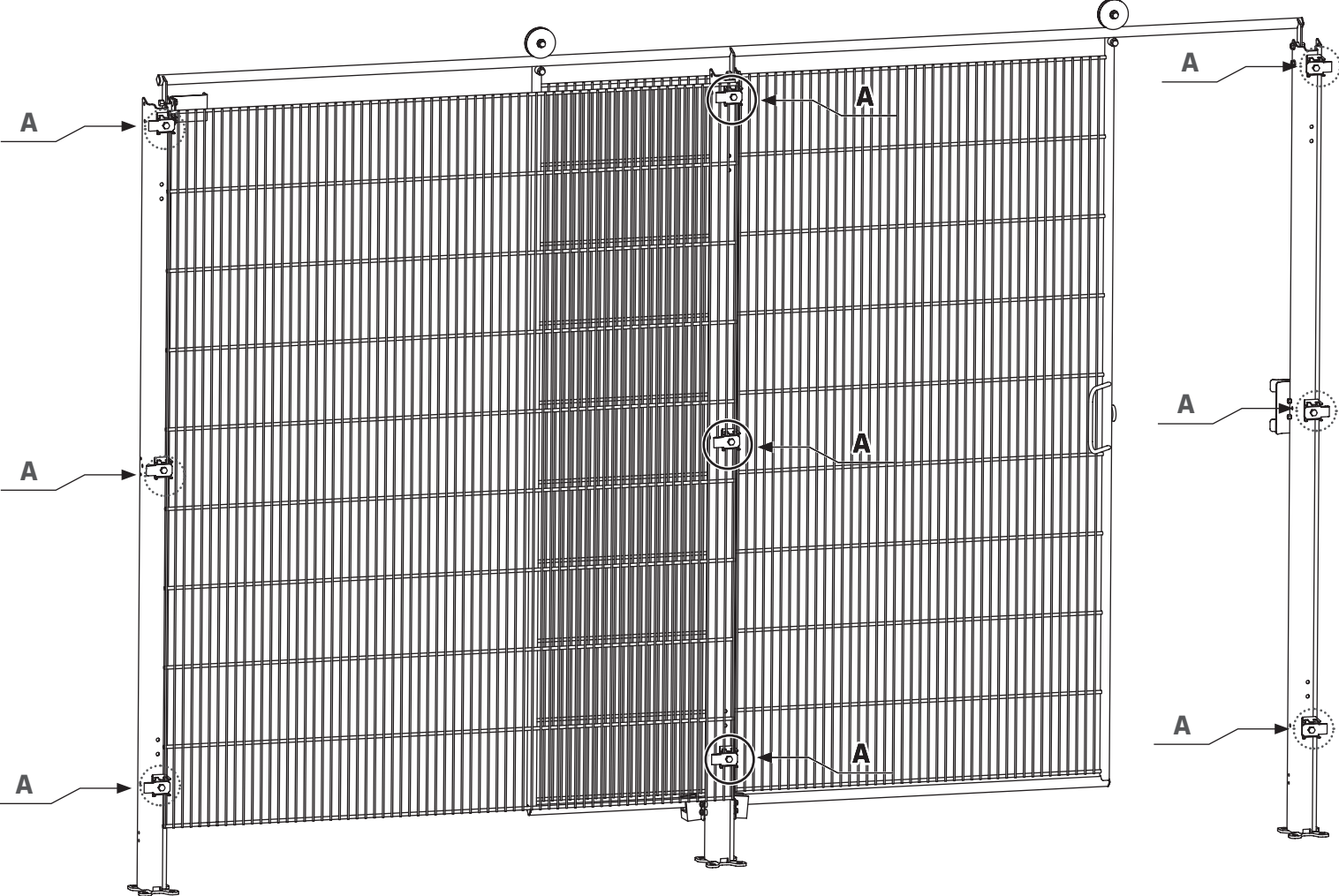



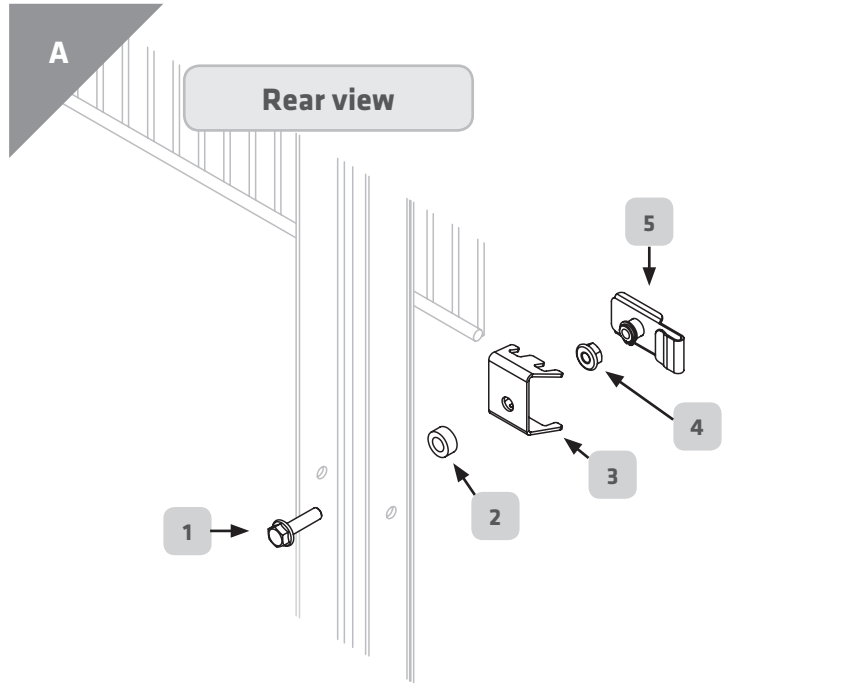

5.2.3. Assembly of 1-leaf sliding door | Order no. YUSTL18015019

DIN left assembly version

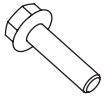
3 x ZB31098

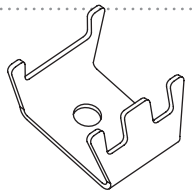

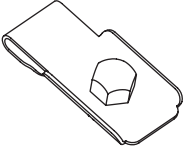
| | | |
|---|----------------------|---|
| 1 | 3 x DIN6921 A2 M8x30 |  |
| 2 | 3 x VA-R 00031 |  |
| 3 | 3 x VA-B00030 |  |
| 4 | 3 x DIN6923 A2 M8 |  |
| 5 | 3 x ZB31046 |  |

5.2.3. Assembly of 1-leaf sliding door | Order no. YUSTL18015019

DIN left assembly version

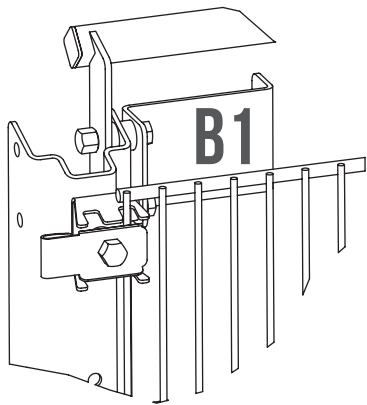
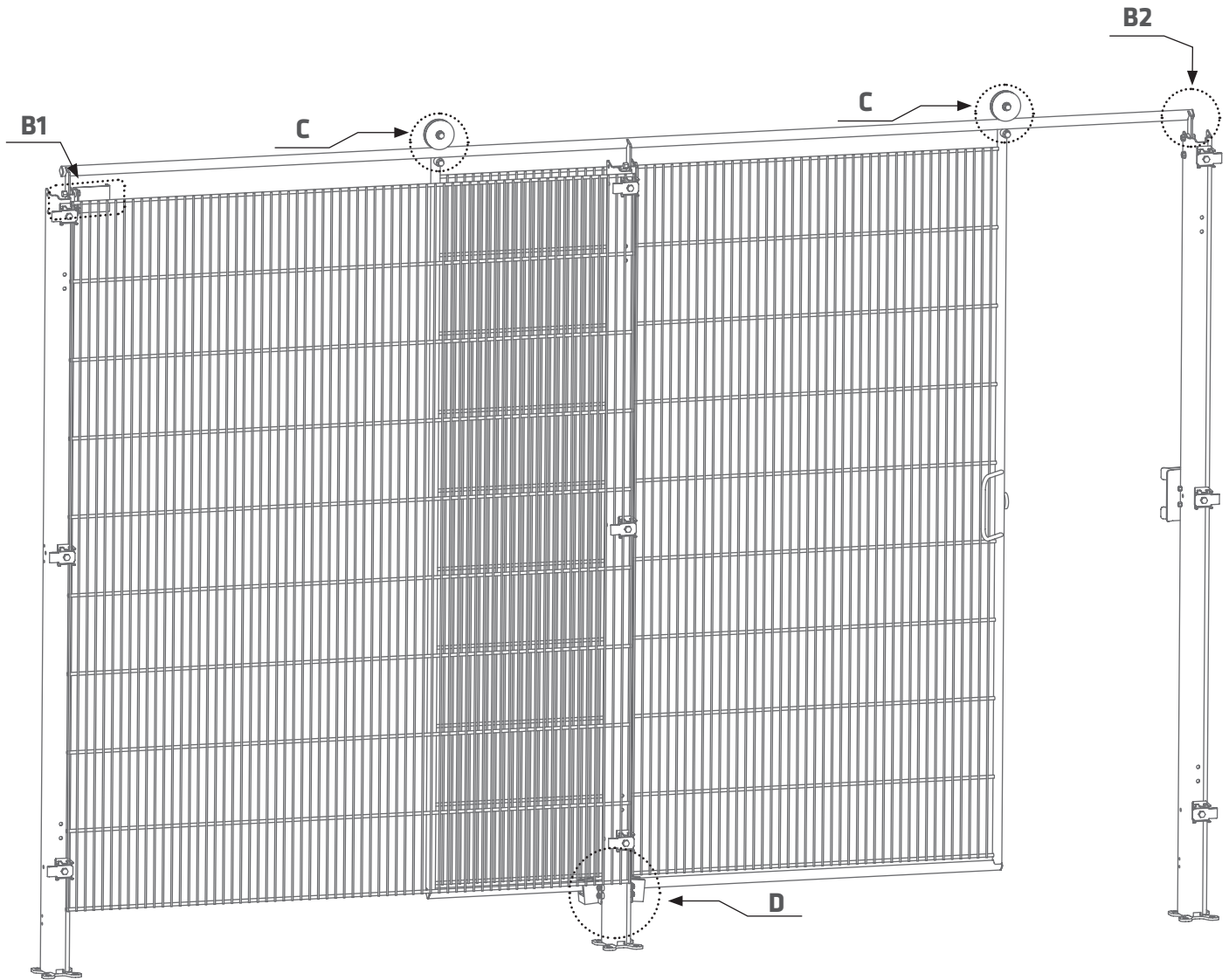

Rear view

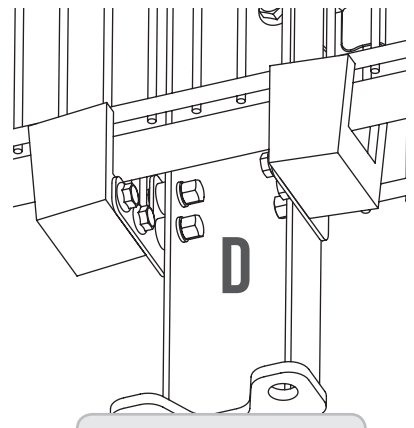
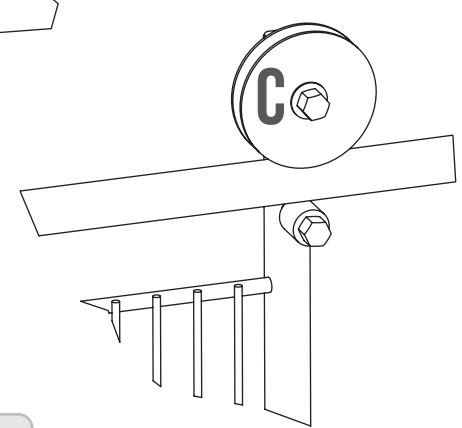
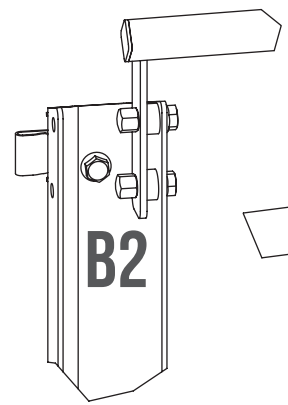

Rear view

5.2.3. Assembly of 1-leaf sliding door | Order no. YUSTL18015019

DIN left assembly version

TSM-10028

B1

Rear view

B2

Rear view

| | | |
|----------|------------------------------|--|
| 1 | 1 x VA-B00073 | |
| 2 | 8 x VA-R00031 | |
| 3 | 2 x DIN 6921 A2-M8x35 | |
| 4 | 4 x DIN 6921 A2-M8x20 | |
| 5 | 6 x DIN 917 A2-M8 | |

TSM-10011

C

| | | |
|----------|--------------------------|--|
| 1 | 2 x R00069 | |
| 2 | 2 x VA-R00031 | |
| 3 | 2 x VA-R00045 | |
| 4 | 2 x VA-R00052 | |
| 5 | 4 x DIN 917 A2-M8 | |
| 6 | 2 x TSB-10034 | |

2 x TSM-10010

D

Rear view

| | | |
|----------|-------------------------------|--|
| 1 | 2 x FR00001 | |
| 2 | 2 x VA-B00077 | |
| 3 | 4 x VA-R00039 | |
| 4 | 4 x DIN 6921 A2-M6x20 | |
| 5 | 4 x DIN 6921 A2-M6x16 | |
| 6 | 4 x DIN 917 A2-M6 | |
| 7 | 4 x DIN 125 A2 - A 6.4 | |

5.2.3. Assembly of 1-leaf sliding door | Order no. YUSTL18015019

DIN left assembly version

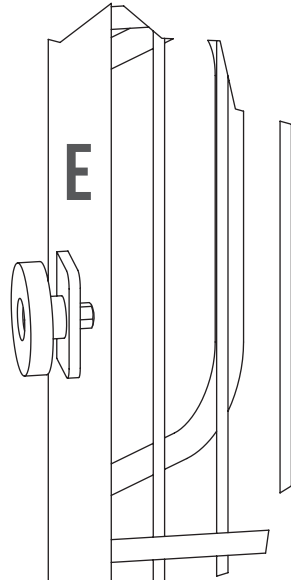
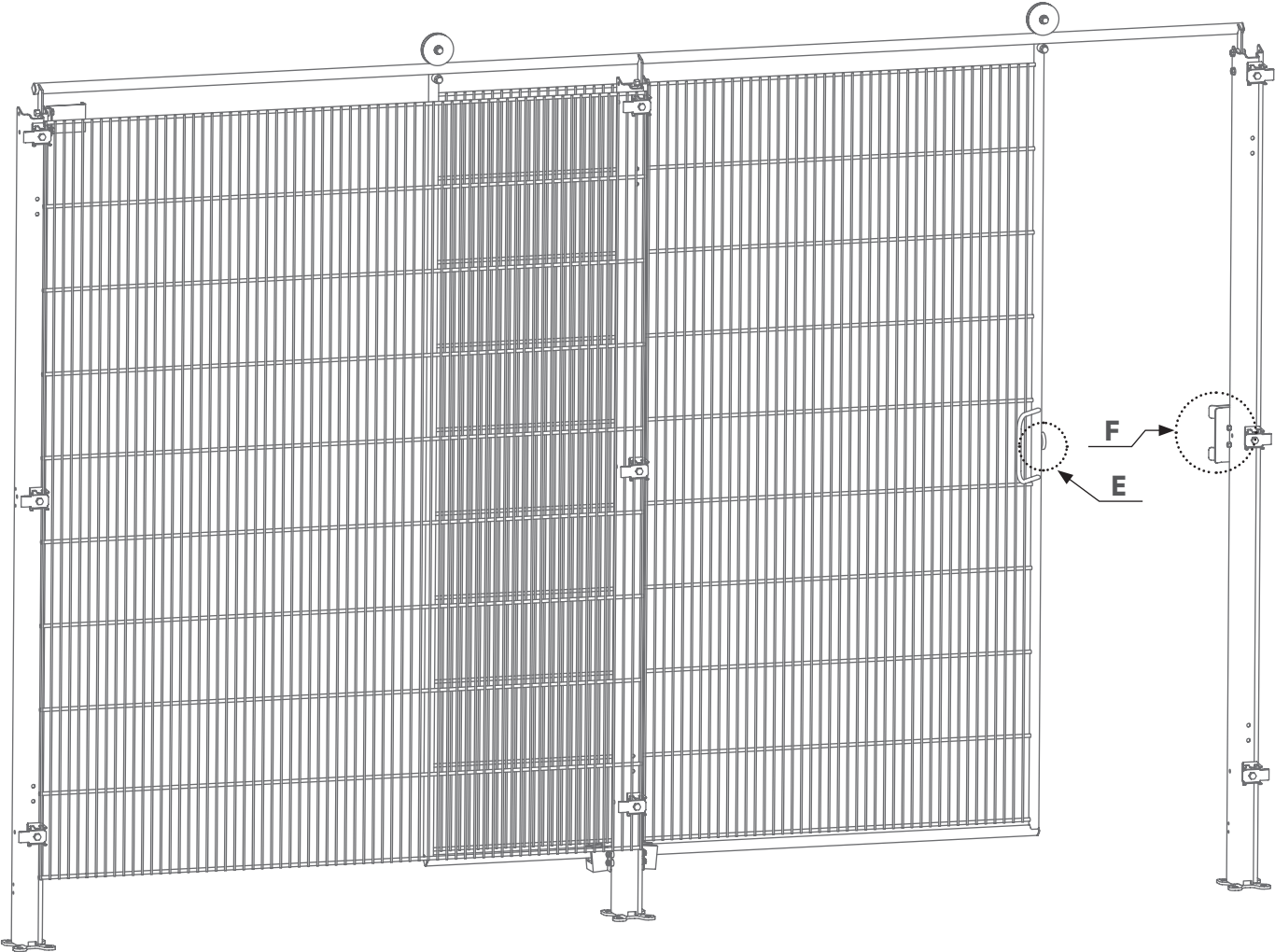

Rear view

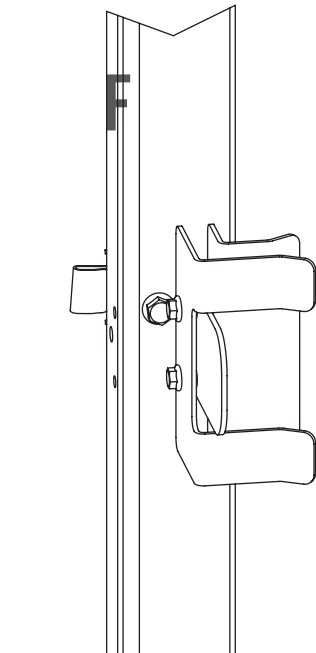

Rear view

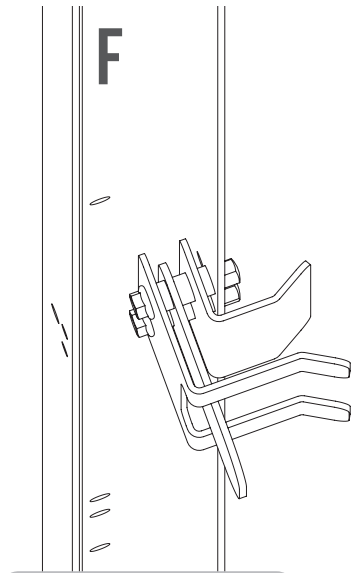

Rear view

5.2.3. Assembly of 1-leaf sliding door | Order no. YUSTL18015019

DIN left assembly version

ZB31119

E

Rear view

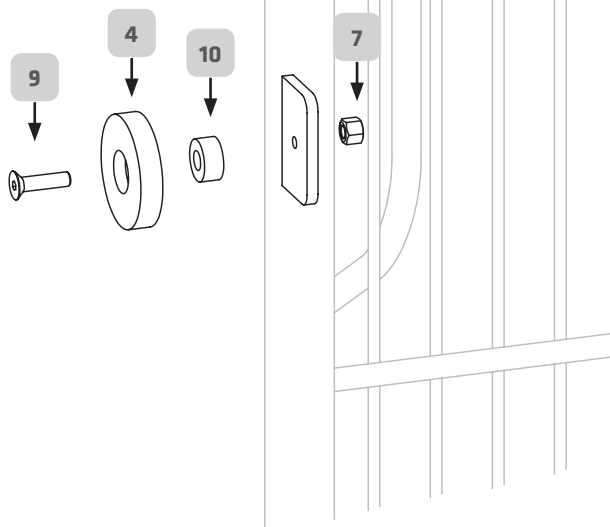

1 1 x VA-B00074

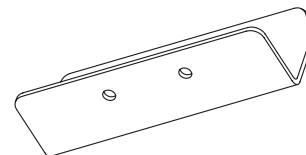

2 1 x VA-B00075

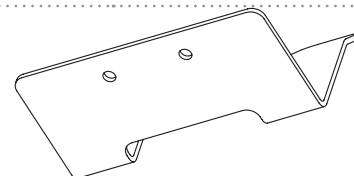

3 1 x VA-B00094

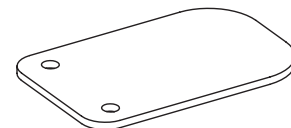

4 1 x GN50-45-HF-40



5 6 x VA-R00055



6 2 x DIN 917 A2-M6



7 1 x DIN 917 A2-M5



8 2 x DIN 6921 - A2 M6x35

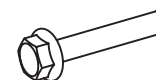

9 1 x DIN 7991 - A2 M5x20



10 1 x VA-R00055



F

Rear view

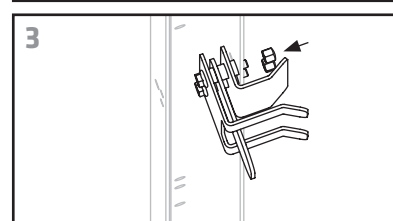
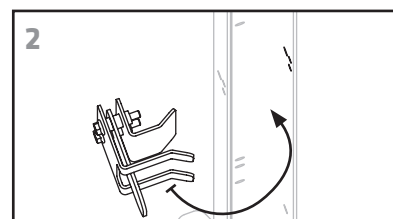
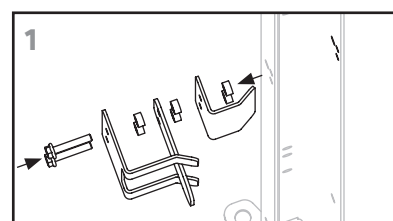
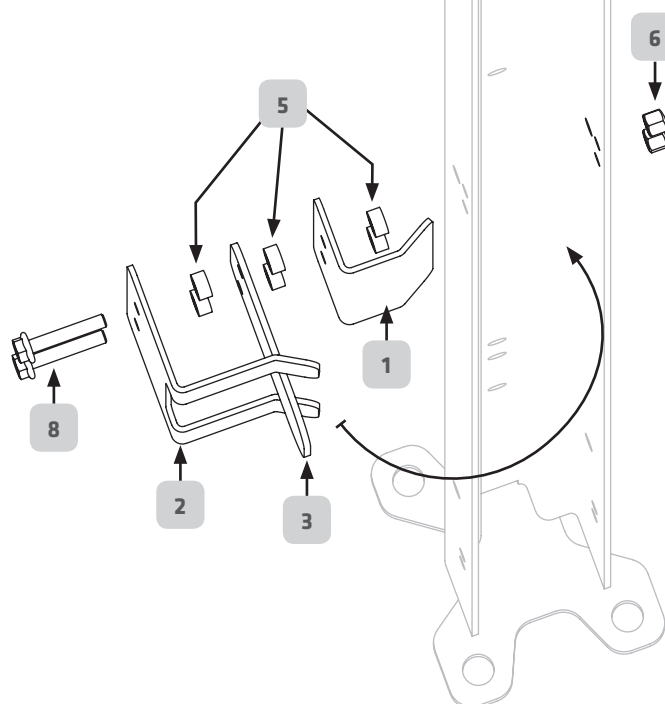

5.2.3. Assembly of 1-leaf sliding door | Order no. YUSTR18015019

DIN right assembly version



 2039 mm



Refer to page 10

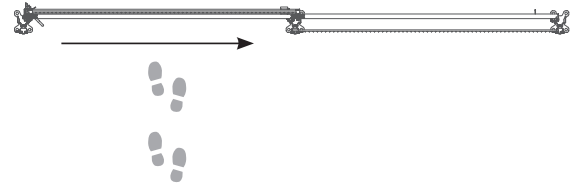

When assembling the fence, always ensure that the correct number of vertical fence rods are in the clamping element.
(Refer to figures 1, 2 and 3)

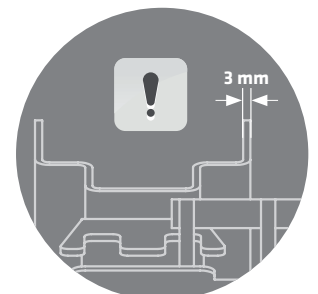
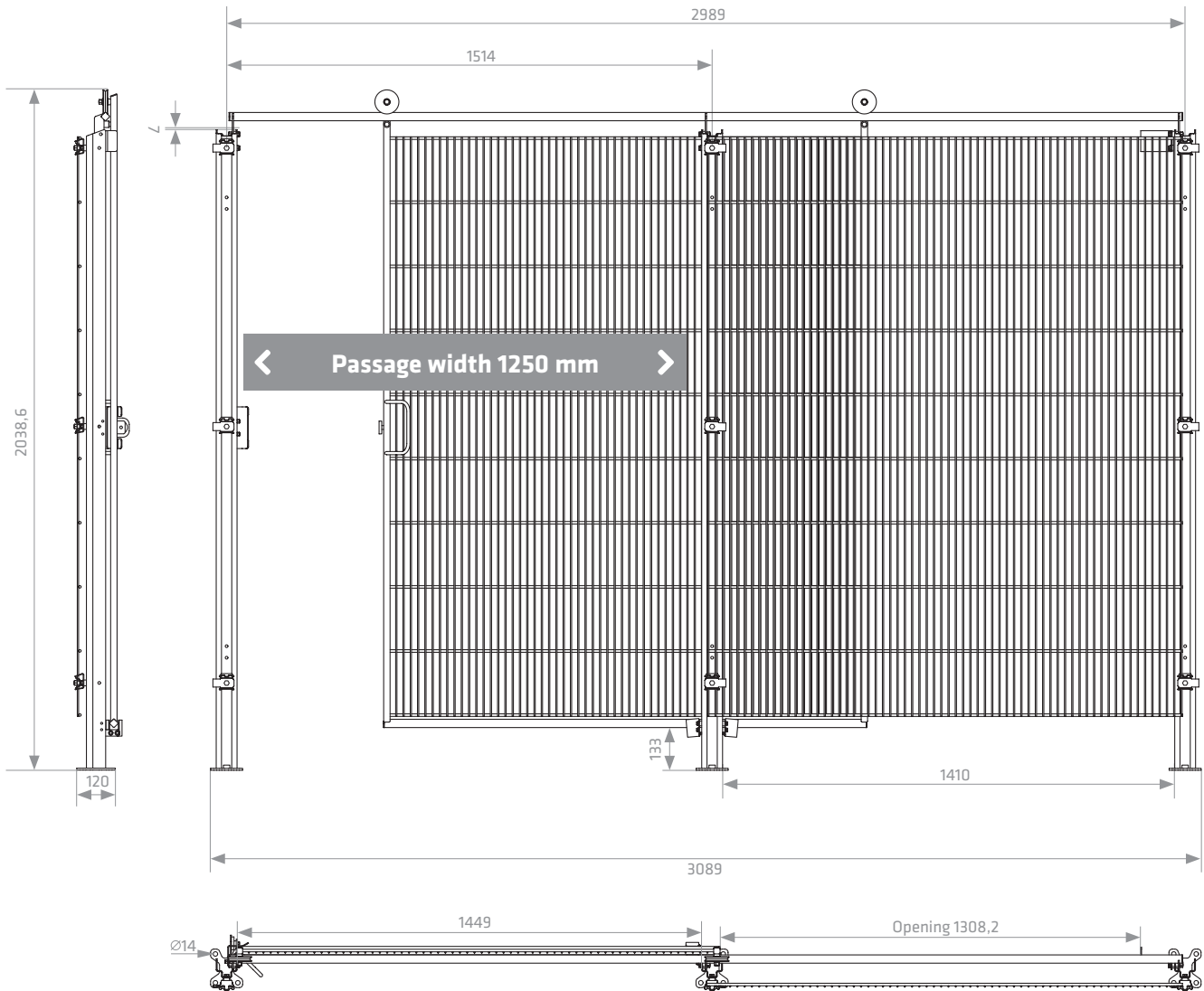
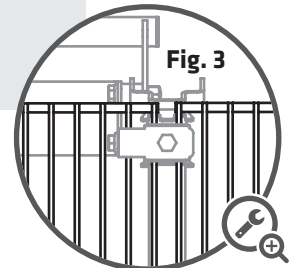
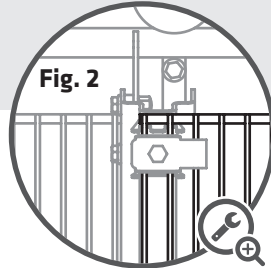
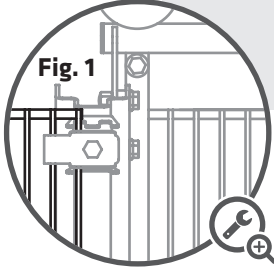

5.2.3. Assembly of 1-leaf sliding door | Order no. YUSTR18015019

DIN right assembly version

Upper cross bar | Order no. VA-S00074

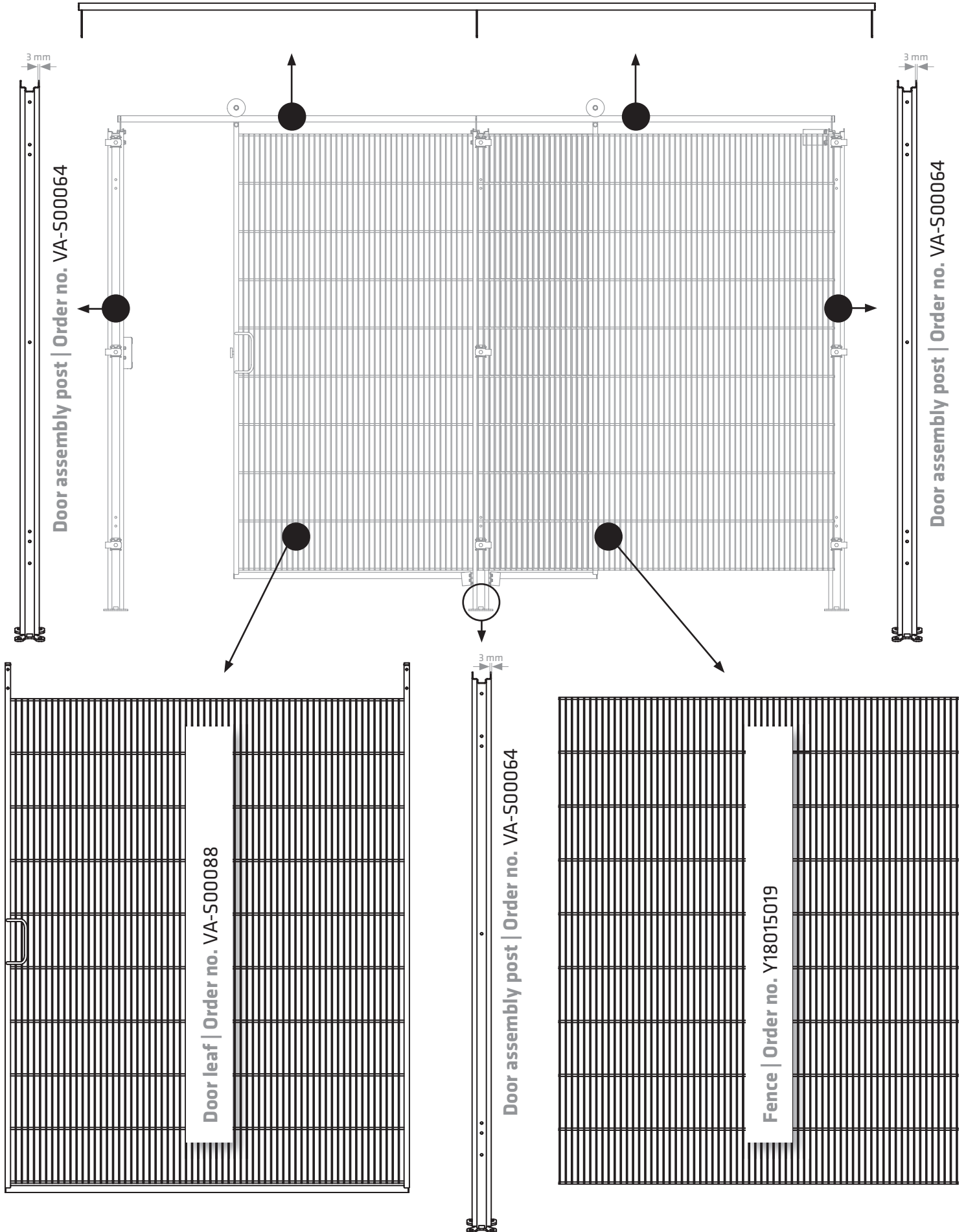

5.2.3. Assembly of 1-leaf sliding door | Order no. YUSTR18015019

DIN right assembly version

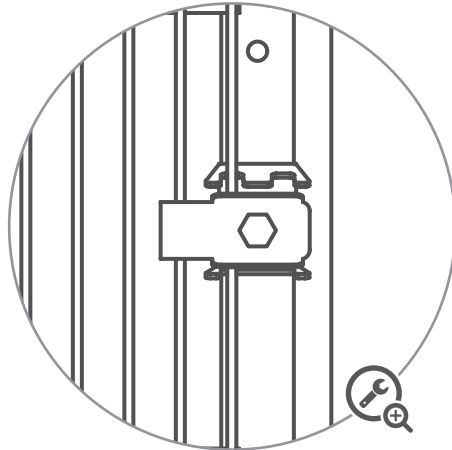
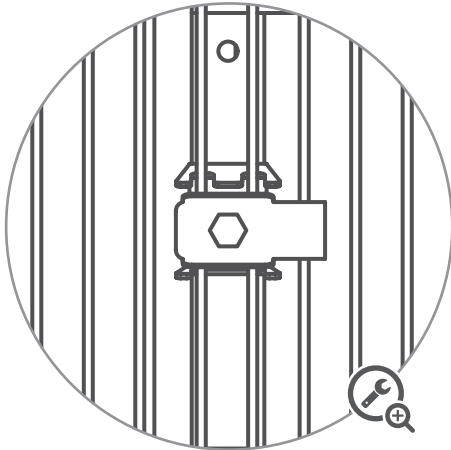
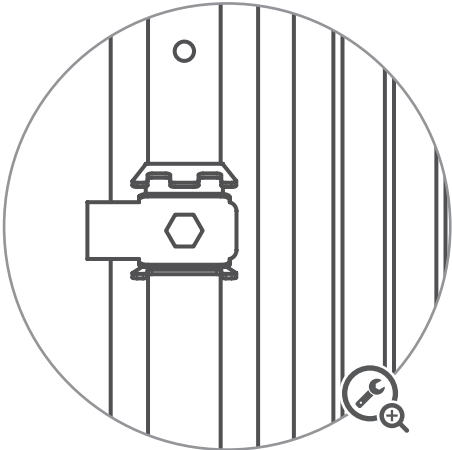
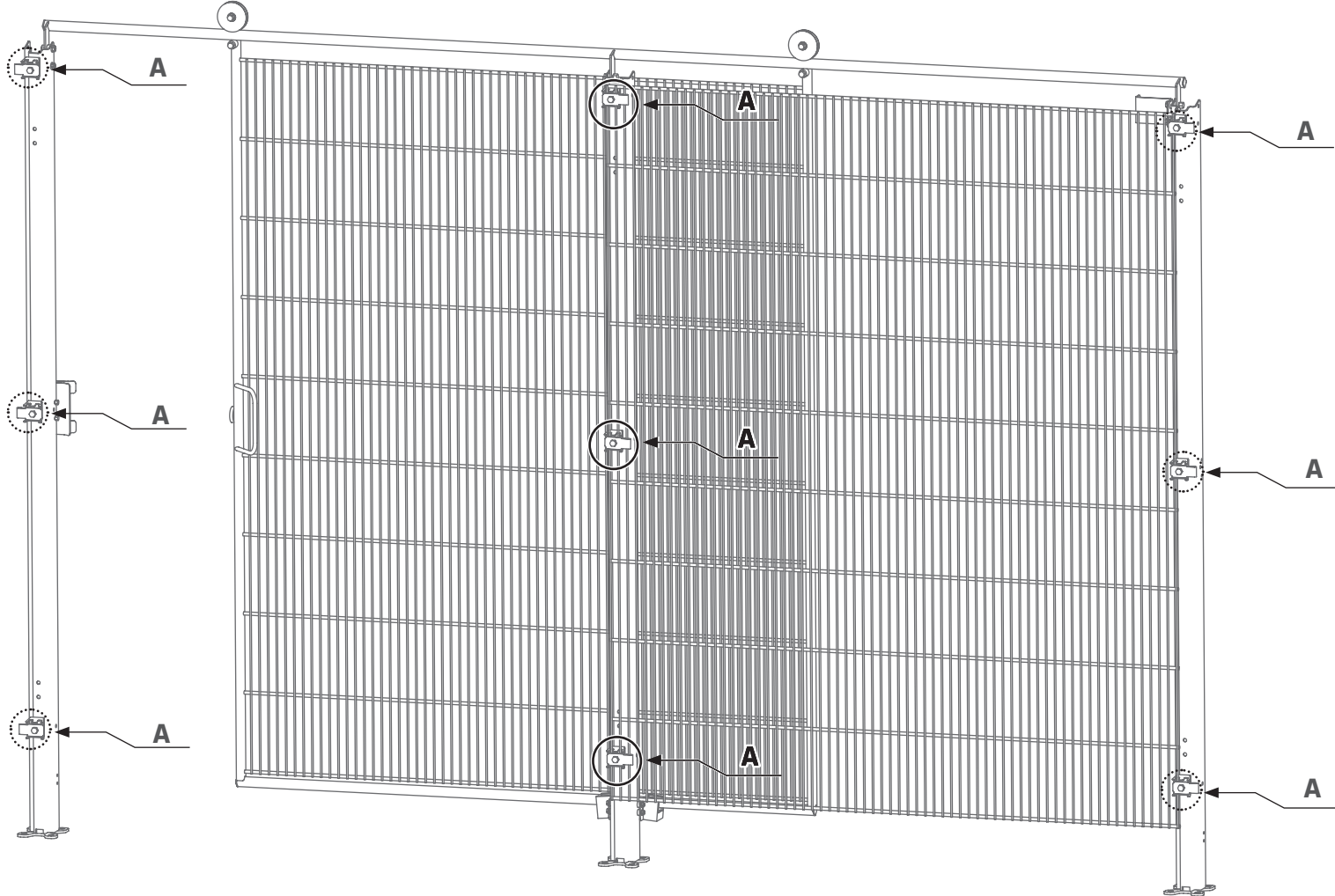

5.2.3. Assembly of 1-leaf sliding door | Order no. YUSTR18015019

DIN right assembly version

3 x ZB31098

A

Rear view

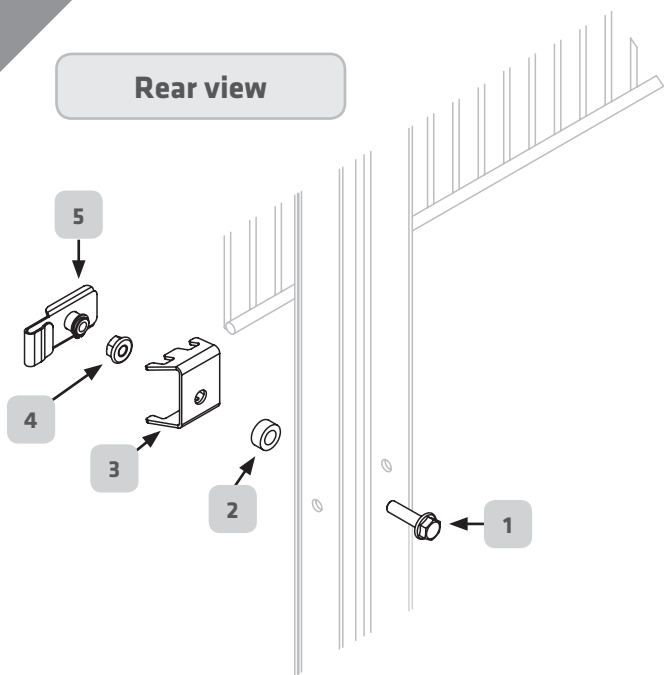

1 3 x DIN6921 A2 M8x30

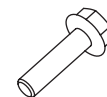

2 3 x VA-R 00031



3 3 x VA-B00030

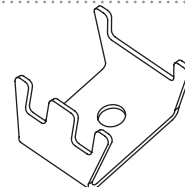

4 3 x DIN6923 A2 M8



5 3 x ZB31046

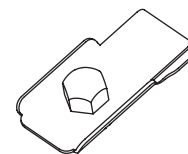

5.2.3. Assembly of 1-leaf sliding door | Order no. YUSTR18015019

Right assembly version

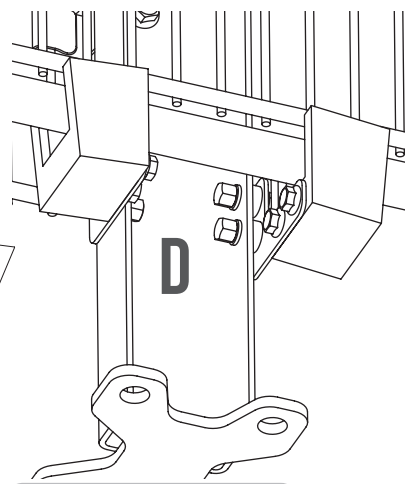
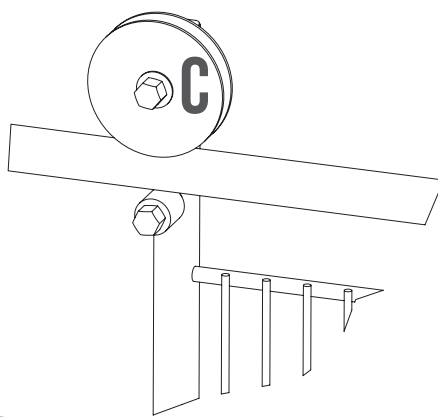
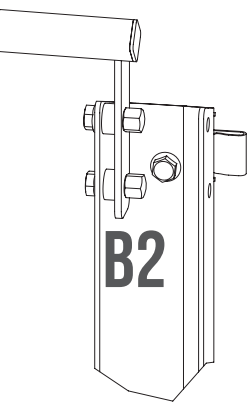
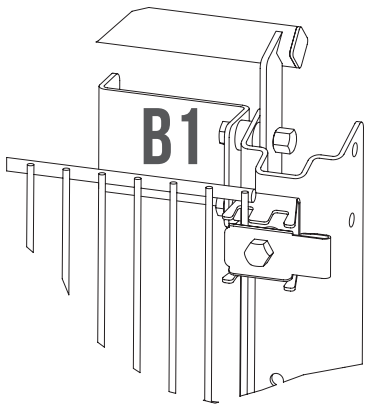
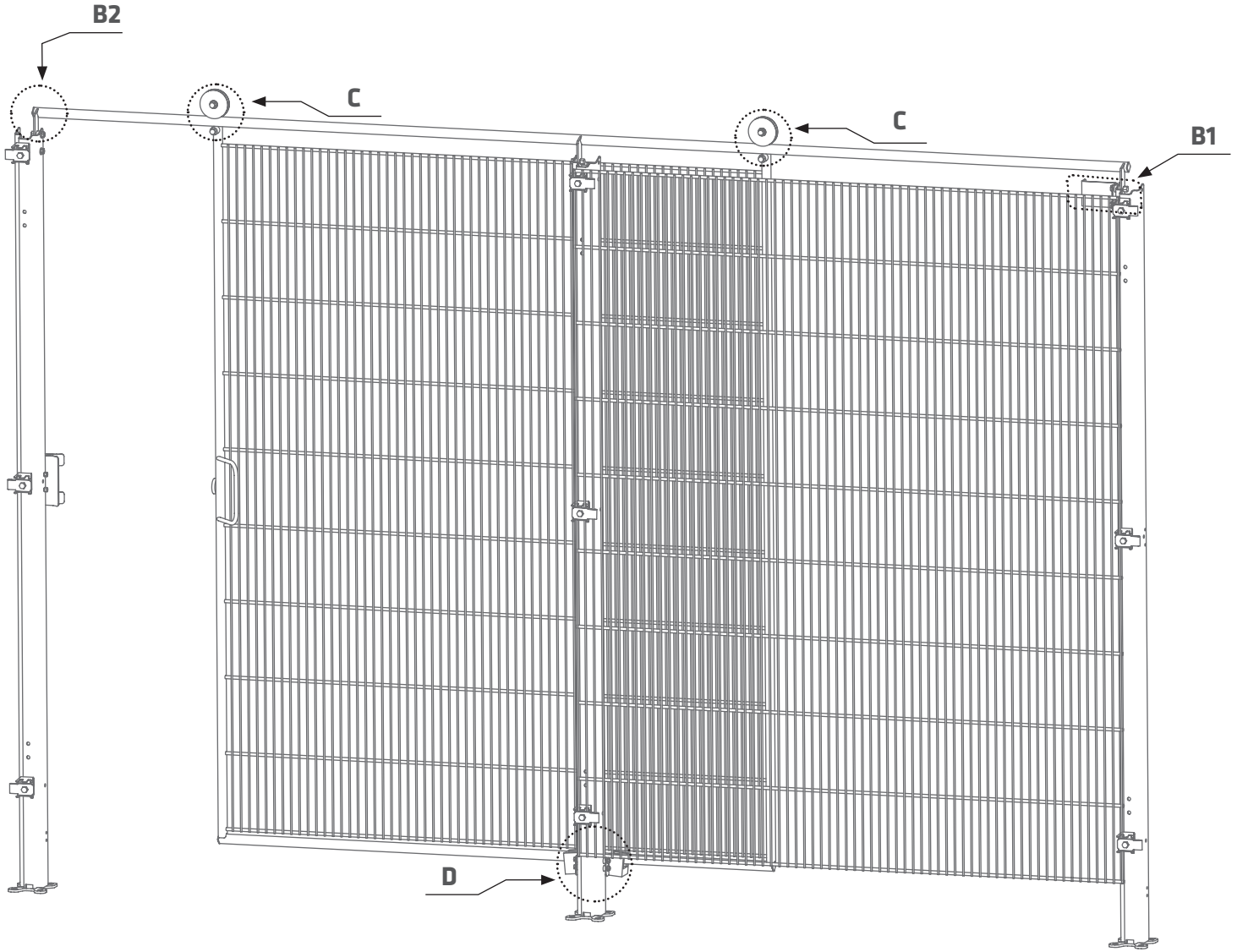

Rear view

Rear view

5.2.3. Assembly of 1-leaf sliding door | Order no. YUSTR18015019

DIN right assembly version

TSM-10009

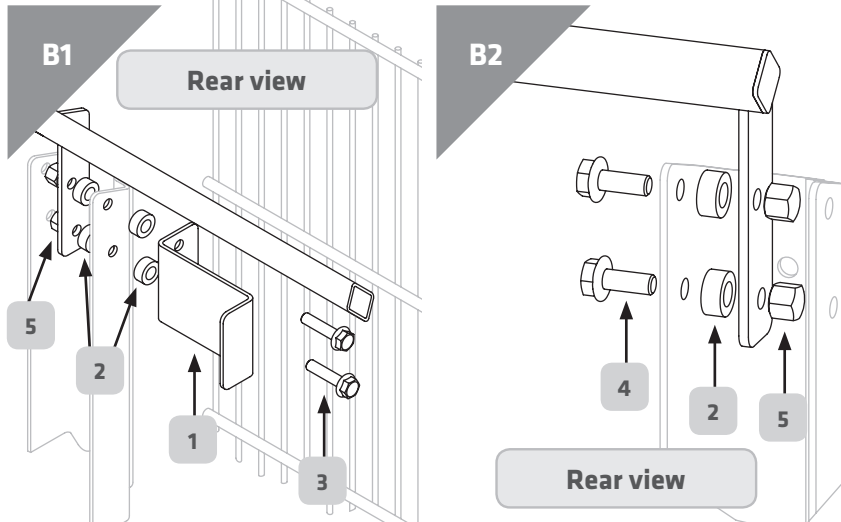

1 1 x VA-B00103

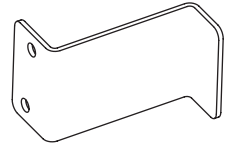

2 8 x VA-R00031



3 2 x DIN 6921 A2-M8x35

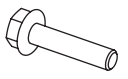

4 4 x DIN 6921 A2-M8x20



5 6 x DIN 917 A2-M8



TSM-10011

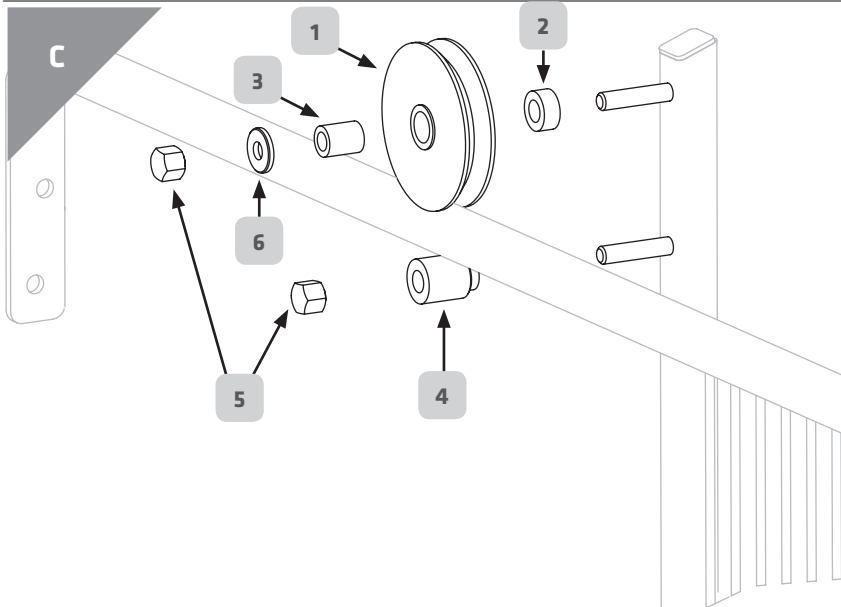

1 2 x R00069

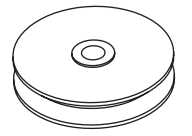

2 2 x VA-R00031



3 2 x VA-R00045



4 2 x VA-R00052



5 4 x DIN 917 A2-M8



6 2 x TSB-10034



TSM-10010

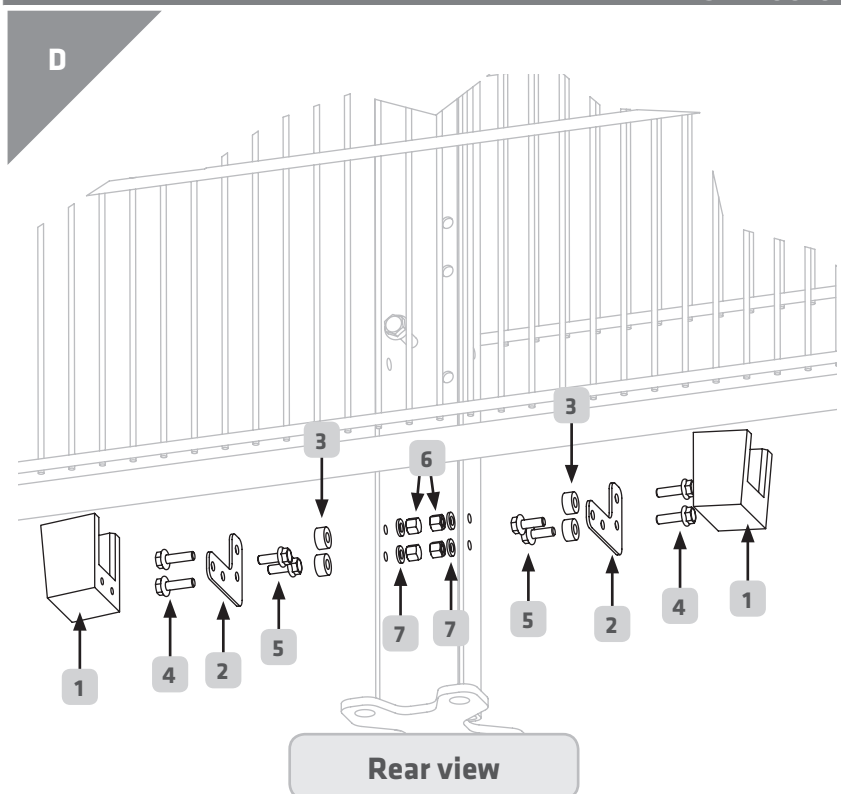

1 2 x FR00001

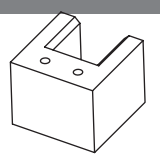

2 2 x VA-B00077

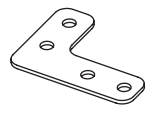

3 4 x VA-R00039



4 4 x DIN 6921 A2-M6x20



5 4 x DIN 6921 A2-M6x16



6 4 x DIN 917 A2-M6



7 4 x DIN 125 A2 - A 6.4



5.2.3. Assembly of 1-leaf sliding door | Order no. YUSTR18015019

DIN right assembly version

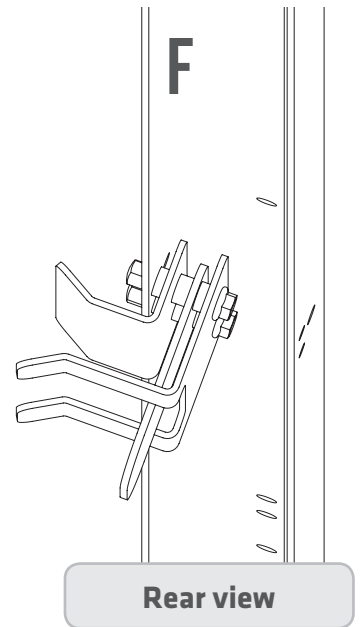
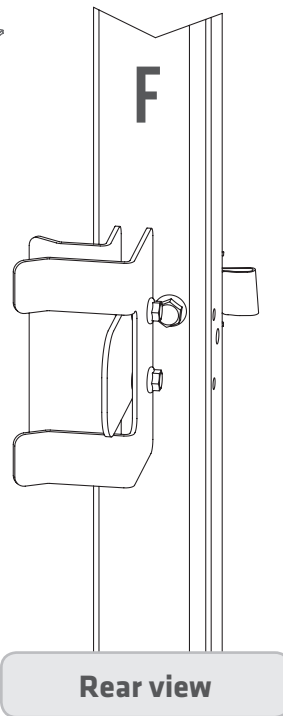
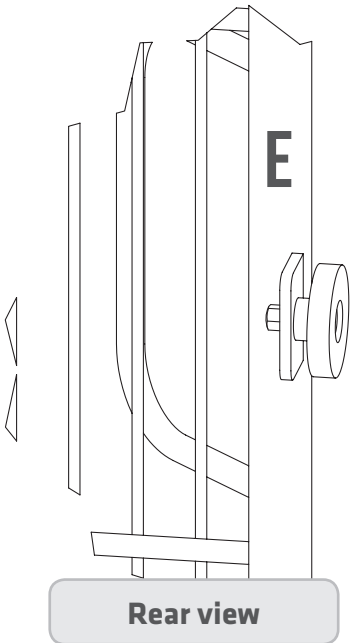
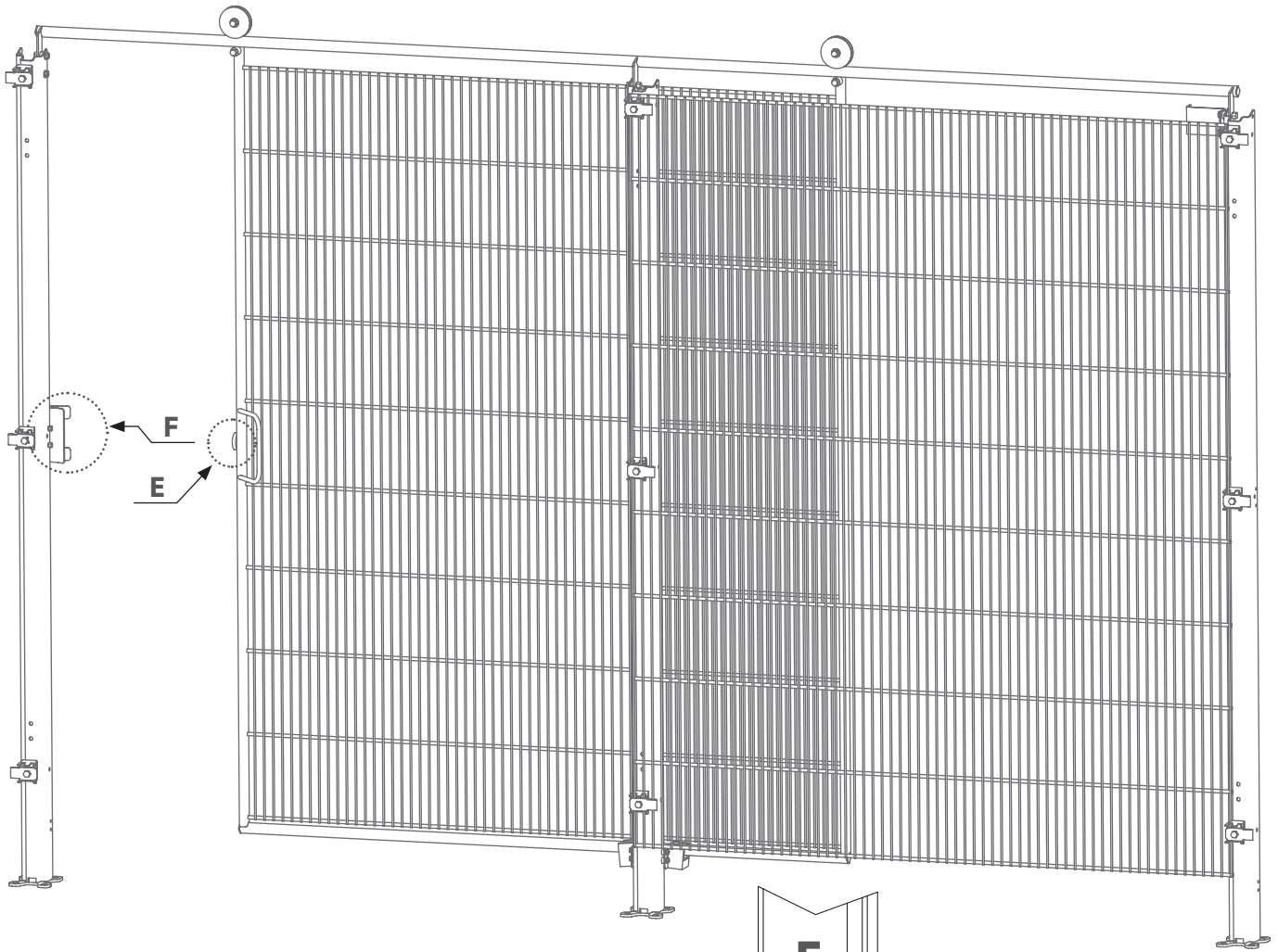

DIN right assembly version

ZB31119

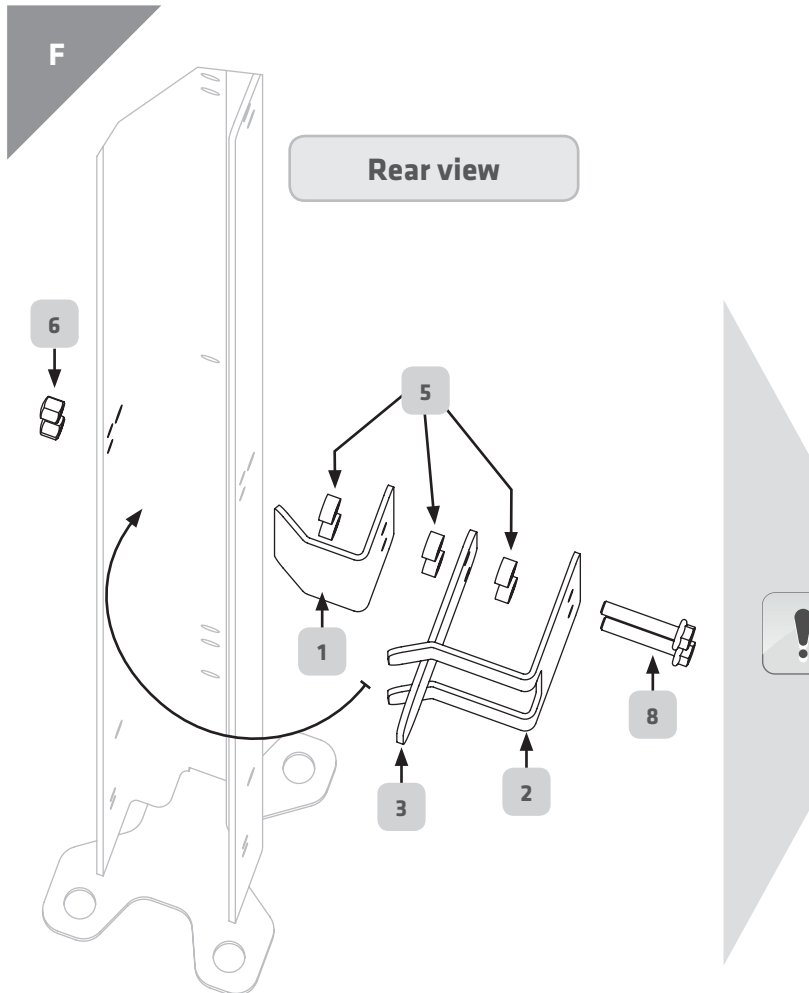
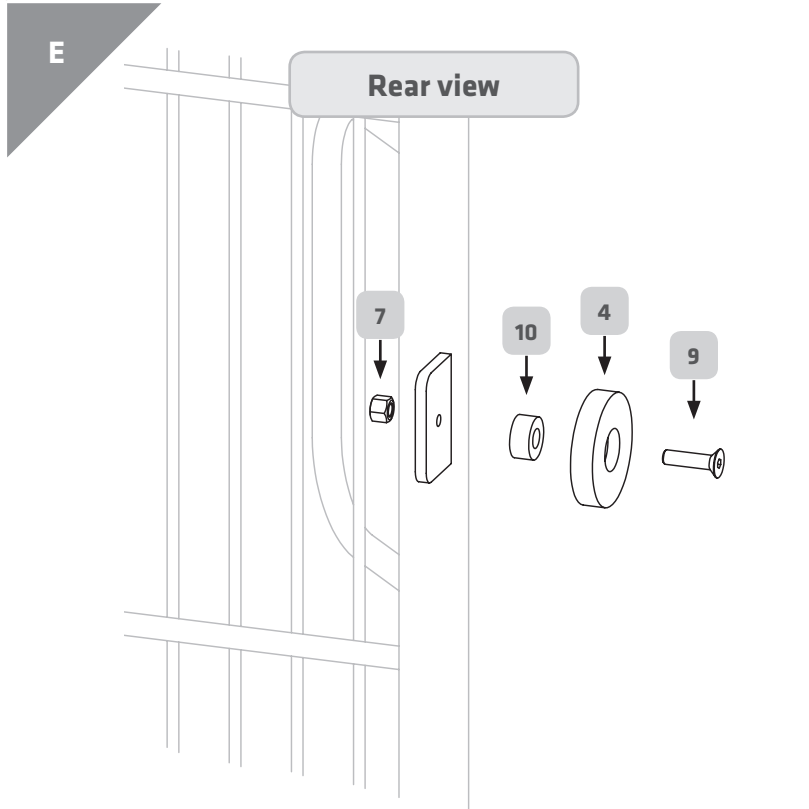

| | | |
|----|-------------------------|--|
| 1 | 1 x VA-B00074 | |
| 2 | 1 x VA-B00075 | |
| 3 | 1 x VA-B00094 | |
| 4 | 1 x GN50-45-HF-40 | |
| 5 | 6 x VA-R00055 | |
| 6 | 2 x DIN 917 A2-M6 | |
| 7 | 1 x DIN 917 A2-M5 | |
| 8 | 2 x DIN 6921 - A2 M6x35 | |
| 9 | 1 x DIN 7991 - A2 M5x20 | |
| 10 | 1 x VA-R00055 | |

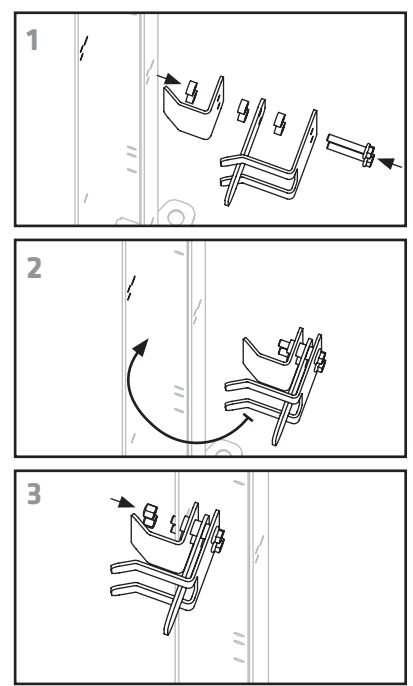

5.3 Providing openings in fence elements

The size and position of openings must not affect the stability of the fence element.

Adhere to the minimum safety distances from hazard areas around openings as per DIN EN ISO 13857.

Adhere to the requirements of DIN EN 619 for the openings of conveyor aids (e.g. conveyor belt, roller conveyor, etc.).

Wear safety goggles and ear protectors when processing the sections using cutting grinders (Flex).

After a cutting process, deburr or pickle the interfaces. Use of edge strips is recommended.



6. Cleaning

The cleaning is normally carried out on the ready-to-use protective fencing system, i.e. there is no need to dismantle or remove individual parts.

Cleaning with a steam jet with clear water and a maximum pressure of 6-8 bar is recommended.

Information regarding suitable cleaning agents is given on page 55 (Ecolab).

Do not use hydrochloric acid or chlorine-containing cleaning agents.



| | |
|------------------------------|---|
| Reason for inspection | Inspection of the material suitability of the "Hygiene fence" test specimen |
| Manufacturer: | Tiemann Schutz-Systeme GmbH Lübbecke Straße 16 32257 Bünde Contact person: Mr. Tiemann frank.tiemann@econference.com |
| QM method | QS R&D/40-1 |
| Specimen identifier | "Hygiene fence" test specimen SER00122 |
| Product description | P3-topax 56, P3-topax 66, P3-topax 990, P3-topactive 200, P3-topactive OKTO |

Execution:

Test specimens were washed with deionised water and dried. These test specimens were then stored in the application solution at room temperature for 28 days.

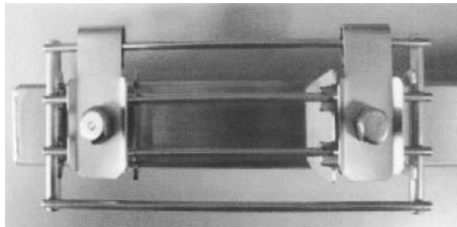

Original view of upper part

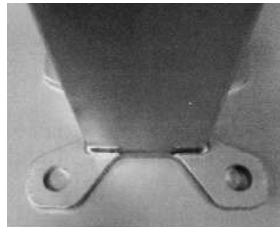

Original view of lower part

Cleaning solutions were changed every 7 days and disinfectant solutions were changed every 3 days. After the end of the immersion time, test specimens were thoroughly washed with deionised water and dried. They were then visually inspected. Results:

Inspected test specimens are considered to be resistant to the used P3 products P3-topax 56, P3-topax 66, P3-topax 990, P3-topactive OKTO and P3-topactive 200 as far as material technology is concerned. Traces or corrosion or changes were not observed in any of the test specimens.

Test results are documented in the following table:

HYGIENEFENCE SER00122

| Test specimen No. | Test product* | Test conditions | | | | Evaluation |
|---|---------------------|---|-------|-------------|------|------------|
| | | H ₂ O | Conc. | Temperature | Time | |
| | Deionised water | 0 | - | RT | 28 | + |
| | P3-topax 56 | 0 | 5 | RT | 28 | + |
| | P3-topax 66** | 0 | 3 | RT | 28 | + |
| | P3-topax 990** | 0 | 3 | RT | 28 | + |
| | P3-topactive 200 | 0 | 5 | RT | 28 | + |
| | P3-topactive OKTO** | 0 | 3 | RT | 28 | + |
| Remark * All solutions are in the deionised water ** Solution replaced after every three days LK = pitting SpRK = stress corrosion | | Legend + resistant/suitable 0 partially resistant/suitable - not resistant/suitable 1) Colour change 2) Surface attack 3) Rust formation 4) White deposit 5) Local corrosion (e.g. LK, SpRK) 6) Cracks 7) Some components dissolved / detached | | | | |

7. Maintenance

The HYGINEFENCE® protective fencing system is maintenance-free in principle.



To ensure the safety function, annual inspections must be carried out by the ! experts of the operating company. Replace the damaged parts.

8. Dismantling and disposal

Two persons are required for dismantling; only experts may carry out this activity.



Before dismantling, switch off the machine or the system or bring it to a safe condition.

If necessary, de-energise the electrical devices install on the protective fencing system or bring them to a safe condition.

Dispose of in accordance with the local regulations of the authorities.

9. Spare parts and accessories

All article numbers given in these Operating Instructions are the order numbers at the same time, unless otherwise noted.

| Order No. | Description | Fig. |
|-----------|--|------|
| ZB20028 | Hilti shear connector cartridge HVU M10x90 with anchor rod HAS-R M10x90/21 for non-cracked concrete | 7 |
| ZB40005 | Fence blanks and cut outs for dimension and as per customer layout | |
| ZB40020 | Planning / construction of a protective fencing system using suitable Components with CAD, in 2 or 3 D, with an installation plan and identification of components | |
| | | |
| | Subject to technical modifications. | |







A series of horizontal dotted lines spanning the width of the page, providing a guide for handwriting practice.



...we protect people!

TIEMANN

Schutz-Systeme GmbH

Lübbecker Str. 16

32257 Bünde

Germany

Fon +49 (0)5223 791995-0

Fax +49 (0)5223 791995-90

www.hygienefence.com

info@hygienefence.com



BA-100043-2

