

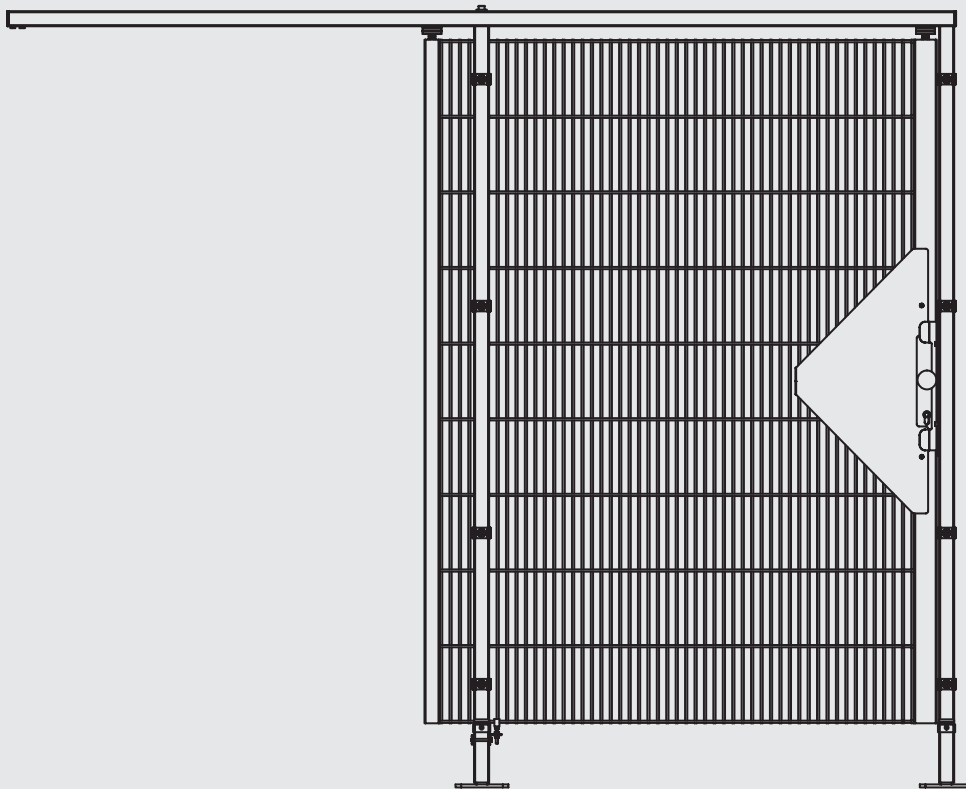

These operating instructions contain important product information and safety instructions. This information must be taken into consideration prior to carrying out any activities relating to the product and observed throughout. These operating instructions must be made available to all parties and stored in a safe place.



...we protect people!



**TRANSLATION OF THE ORIGINAL
OPERATING INSTRUCTIONS**

ECONFENCE®
protection · german made

BASIC LINE

**1-LEAF SLIDING DOOR
VARIANT TS01**

System heights 2000 | 2200 mm
Version: 01/2018



NOTES

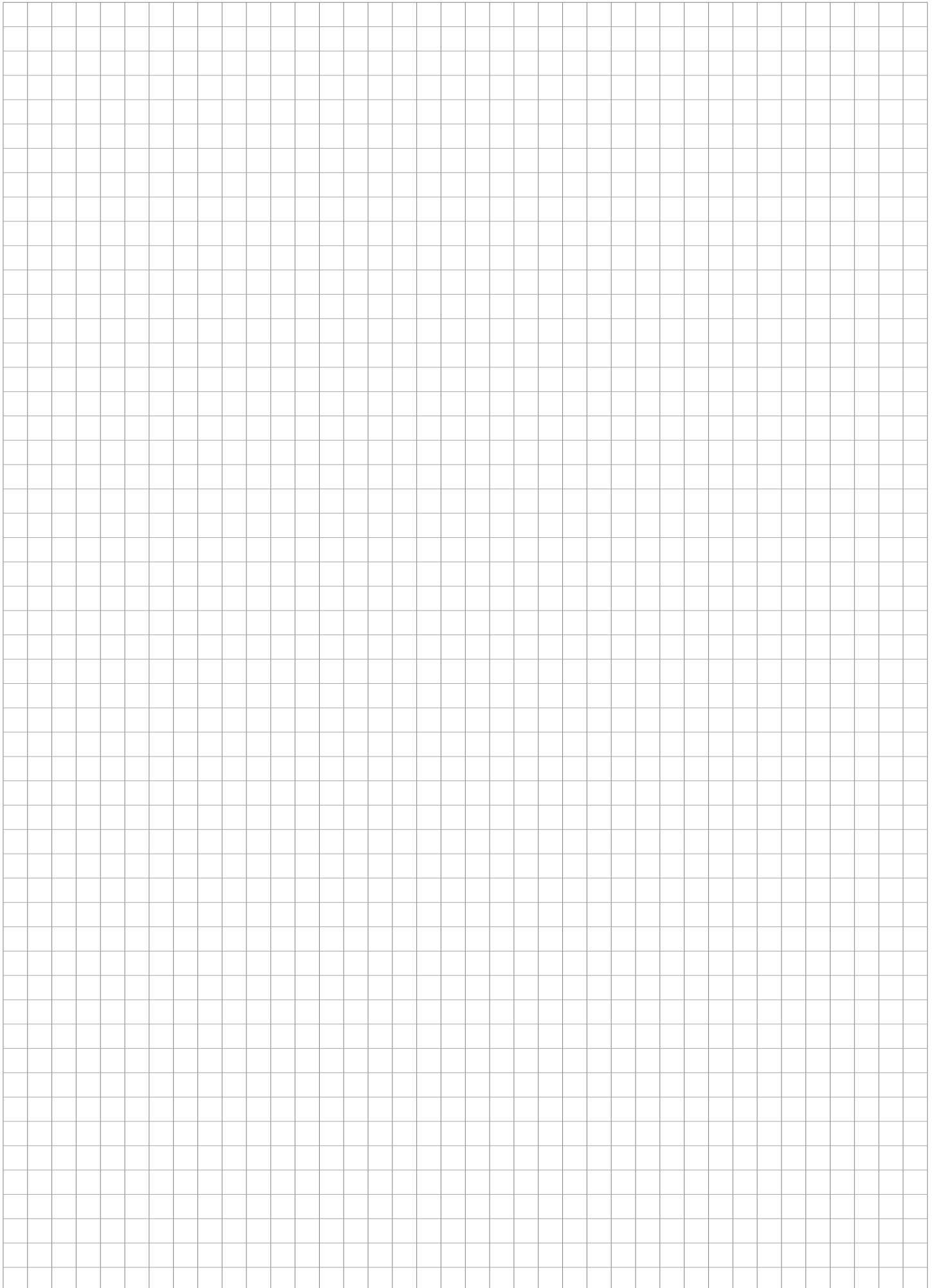
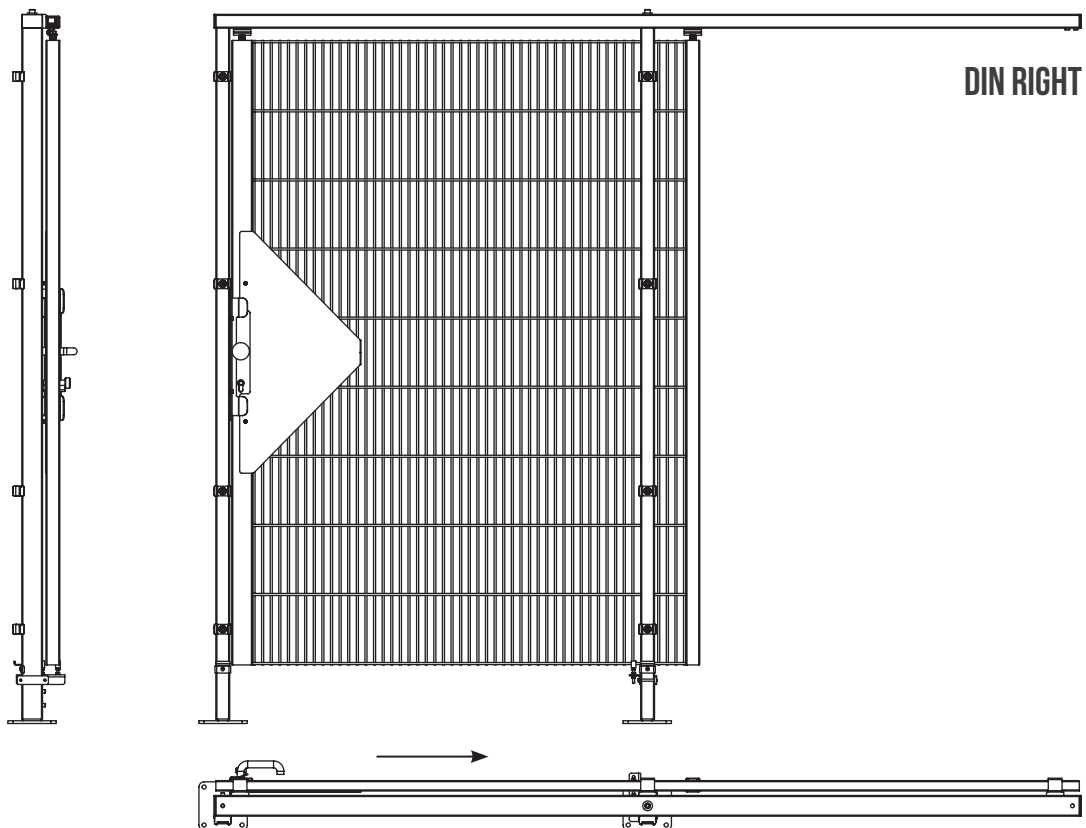
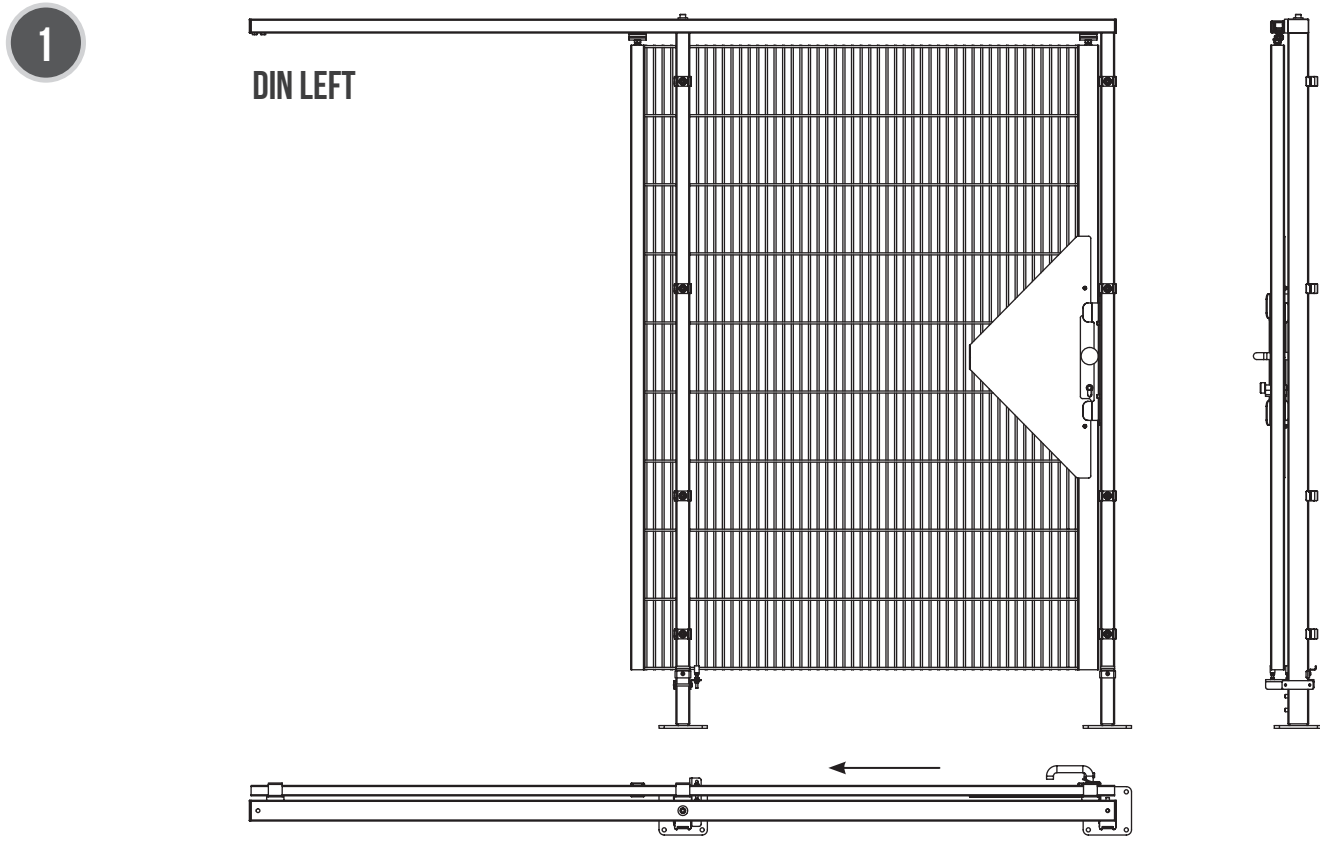

Table of contents

1.	Product description and technical data	Page 4
2.	Intended use and limitations	Page 5
3.	EC Declaration of Conformity	Page 6
4.	Safety instructions and explanation of symbols	Page 7
5.	Assembly and installation	Page 8 - 37
	5.1. Essential tools	Page 9
	5.2. Fastening to the substrate	Page 10
	5.3. Interface for fixing locking devices	Page 11
	5.4. Installation 1-leaf sliding door	Page 12 - 35
	5.5. Installation on the protective mesh	Page 36 - 37
6.	Maintenance	Page 38
7.	Disassembly and disposal	Page 38
8.	Accessories	Page 39

1. Product description and technical data

The 1-leaf sliding doors of the variant TS01 are available in the following designs as standard:



BASIC LINE	Widths (mm)	Opening widths (mm)	Heights (mm)	Base plate (mm)	Weights (kg)
1 1-leaf sliding door Variant TS01 DIN left / right	2554	953	2053	140x140	59.11
	2554	953	2253	140x140	66.97

2. Intended use and limitations

The ECONFENCE® BASIC LINE protective fencing system is designed to establish a fixed, safe distance to protect people from coming into contact with hazardous machinery and facilities in production and warehouse logistics.

The fencing elements are suitable for use as fixed guards and the 1-leaf sliding doors of the variant TS01 are designed for use as guards in combination with locking devices with door handles (in the sense of DIN EN ISO 14119)

according to DIN EN ISO 14120.

The locking devices themselves and their fastening accessories are not part of the scope of delivery. The system manufacturer is responsible for the expert layout and installation of suitable locking devices. This expertise also includes an understanding and observance of the relevant legislation governing safety technology, including e.g. DIN EN ISO 13849. Application of the CE mark provided (type plate) is prohibited until the doors have been completed by the necessary locking devices.

Only operate the guard when it is in perfect technical condition! Taking health and safety at work into account, eliminate any problems which can impair the safety of employees and operational safety without delay!

Any other use shall require the written approval of the manufacturer. If machines or systems are not surrounded entirely by the protective fencing system, the open areas (such as material transfer points and personnel access points) must be secured by the plant engineer in accordance with the risk assessment and the relevant legislation.

Intended use also includes taking the operating instructions into consideration and observing the cleaning, maintenance and inspection conditions. The guard has been designed for industrial machine and system construction and may only be mounted, operated, maintained and repaired by trained, instructed specialists.

The owner / operator must check whether the currently valid standards and regulations require the protective fencing to have a protective earth connection.

The protective earth connection may only be carried out by a qualified electrician.

When incorporating the protective fencing systems into the overall security concept of the machine or system, the following standards must be taken into consideration:

DIN EN ISO 12100	Safety of machinery – General principles for design – Risk assessment and risk reduction
DIN EN ISO 11161	Safety of machinery – Integrated manufacturing systems – Basic requirements
DIN EN ISO 13857	Safety of machinery – Safety distances to prevent hazard zones being reached by upper and lower limbs
DIN EN 349	Safety of machinery – Minimum gaps to avoid crushing parts of the human body
DIN EN ISO 14120	Safety of machinery – Guards – General requirements for the design and construction of fixed and movable guards
DIN EN ISO 14119	Safety of machinery – Interlocking devices associated with guards – Principles for design and selection
DIN EN ISO 13849-1	Safety of machinery – Safety-related parts of control systems – Part 1: General principles for design

Depending on the machine / system constellation, other standards which are not listed here must also be taken into consideration.

The system is not intended for outdoor use. Any kind of manipulation is prohibited.

The protective fencing may only be set up in an environment with temperatures from 10°C to max. 50°C (not corrosive environment).

The machine / system must be switched off before anyone enters the hazardous area (electrical, pneumatic) and secured against unauthorised restarting by means of a lockout/tagout lock. The key must always be carried on your person.





...we protect people!

TIEMANN
Schutz-Systeme GmbH
Lübbecker Straße 16
32257 Bünde | Germany

T+49 (0)5223 791995-0
F+49 (0)5223 791995-90

info@econference.com
www.econference.com

EG-KONFORMITÄTSERKLÄRUNG

im Sinne der EG Maschinenrichtlinie 2006/42/EG, Anhang II A

EC DECLARATION OF CONFORMITY

according to EC Machinery Directive 2006/42/EC, Annex II A

Hersteller | Manufacturer

Tiemann Schutz-Systeme GmbH
Lübbecker Str. 16
32257 Bünde / Germany



Hiermit erklären wir, dass das Produkt

Produktbezeichnung: Trennende Schutzeinrichtung
Typ: ECONFENCE® BASIC LINE TS01

Baujahr bzw. Seriennummer: ab 05/2016

den einschlägigen Bestimmungen der Richtlinie 2006/42/EG entspricht.

Es wurden folgende harmonisierte Normen angewandt:

- DIN EN ISO 14120:2016-05

We hereby declare that the product:

Product designation: Separating guard
Type: ECONFENCE® BASIC LINE TS01

Year of build or serial number: as of 05/2016

meets the relevant provisions of directive 2006/42/EC.

The following harmonised standards have been applied:

- DIN EN ISO 14120:2016-05

Ort
City

Datum
Date

Unterschrift*
Signature*









Axel W. Tiemann
Geschäftsführer
Managing Director

Der Unterzeichner ist verantwortlich für die Zusammenstellung der technischen Unterlagen und gleichzeitig der verantwortliche Herausgeber der technischen Dokumentation.

*The signatory is responsible for the composition of the technical documents and at the same time the responsible publisher of the technical documentation.

4. Safety instructions and explanation of symbols

The safety symbols are to be noted and observed in each of the relevant sections of these operating instructions.

Symbol	Explanation
	Safety instruction (Failure to observe will result in injury or death)
	Functional instruction (Failure to observe will result in malfunctions or material damage)
	Hazardous area
	Non-hazardous area
	Magnified/detailed view
	Installation height
	Essential tools (reference to page 9)
	Use ear protectors
	Use protective eyewear

5. Assembly and installation



At least two people are required for assembly and installation. Wear personal protective equipment or fastened working clothes, wear safety footwear and head protection. In addition, goggles with side protectors must be worn during drilling in concrete. If dusts occur, filter mask of at least FFP 1 must be worn.

Only specialist personnel are authorised to carry out assembly and installation.

Prior to commencing the installation work, the machine or system being enclosed must be switched off or else made safe. The machine / system must be switched off before installation and secured against unauthorised restarting by means of a lock-out/tagout lock. The key must always be carried on your person. Establish / check the required safety distances from the hazardous areas of the machine/system in accordance with DIN EN ISO 13857:

Safety distances according to DIN EN ISO 13857

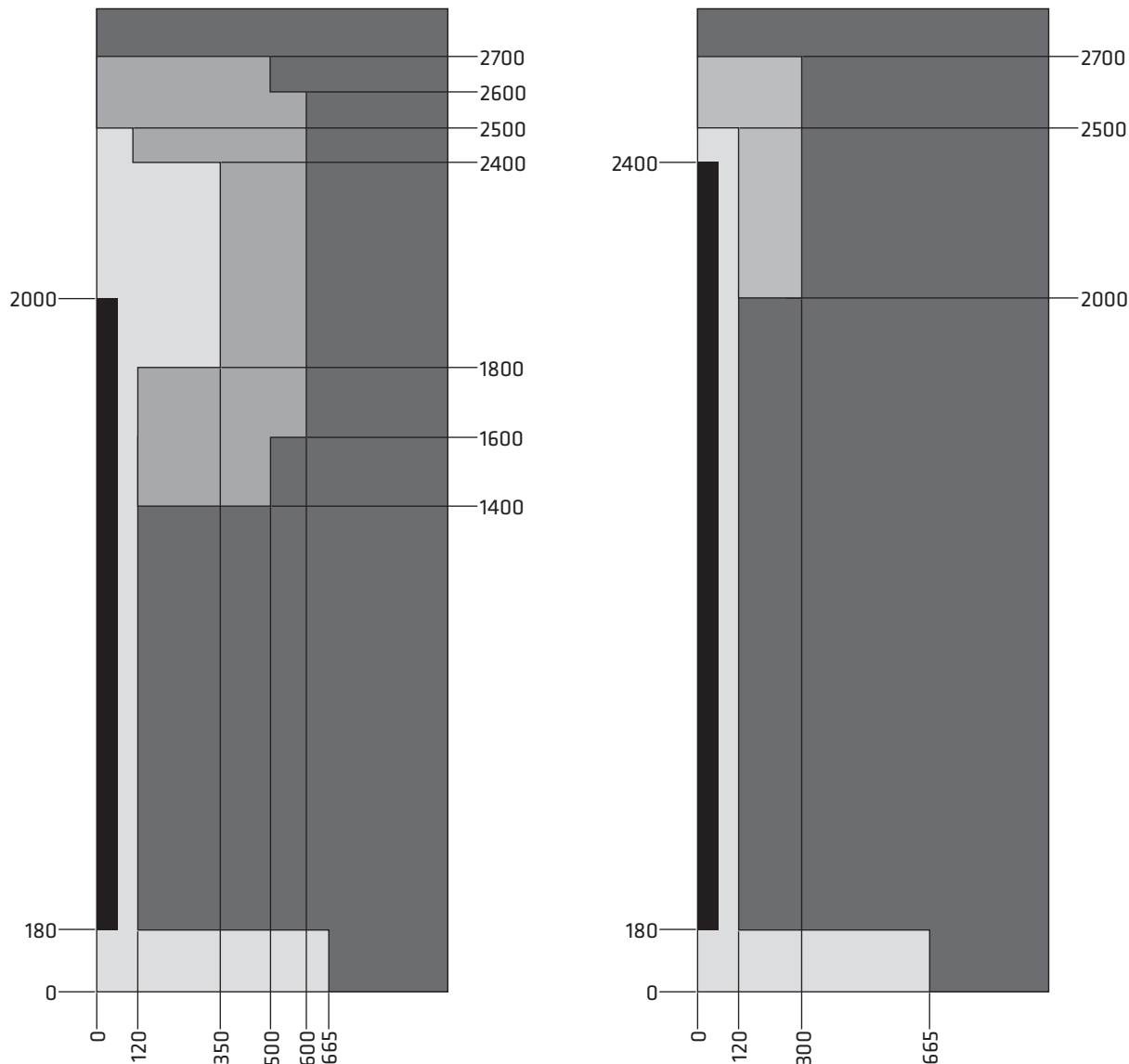

Low risk

High risk

Please note: In the event of a risk posed by slips or misuse, the use of safety distances to prevent hazardous zones being reached by lower limbs in accordance with DIN EN ISO 13857, Annex B may not be suitable. If this is the case, then the safety distances must be defined by the plant manufacturer in accordance with the risk assessment.



Safety distances only apply with the use of ECONFENCE® mesh elements with a mesh size of 19|190 mm. Information on dimensions and weight specifications of the system components can be found in Section 1. Technical data, page 4. The system is only intended to be used on the following surface (see page 10). Only the fastening elements provided are to be used. When installing the electrical equipment (such as cables, switches, control cabinet etc.) for the protective fencing system, the Requirements of DIN EN 60204-1 must be observed.

Should you have any further questions, please contact our Customer Service team on +49 (0) 5223 791995-0

5.1. Essential tools

Product

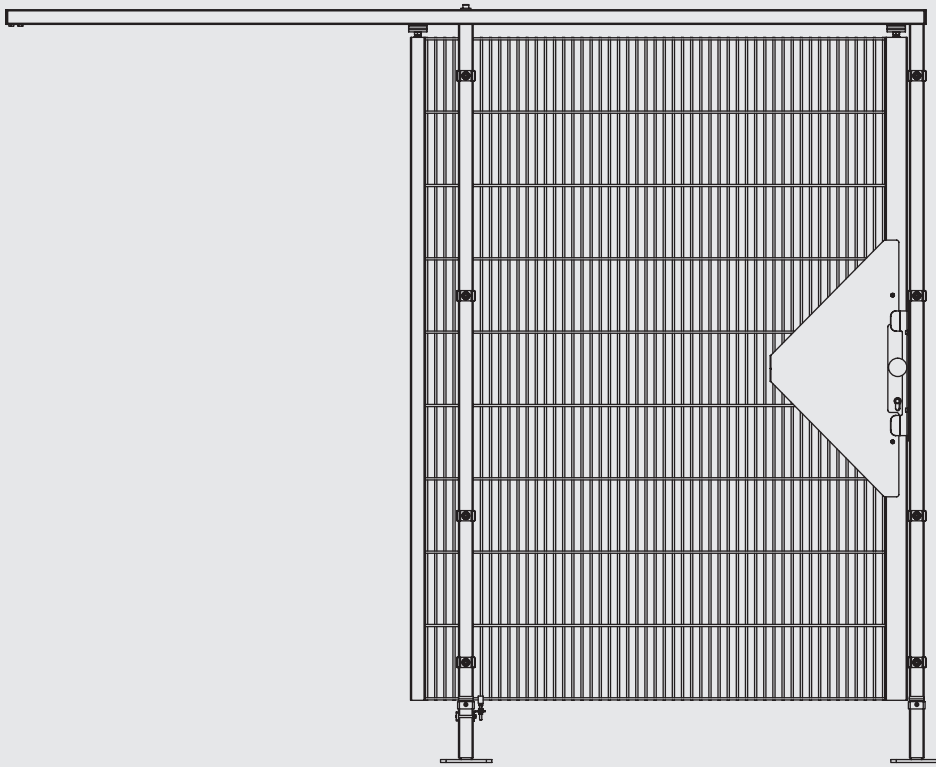

1-leaf Sliding door, variant TS01, installation (page 10-35)



Tools

Drill with
10 mm concrete drill bit
Hammer
13 mm and 17 mm socket wrenches
3 mm, 4 mm, 5 mm and 8 mm Allen keys

5.2. Fastening to the substrate

Substrate material: Concrete (uncracked) C20/25 to C50/60



See page 9

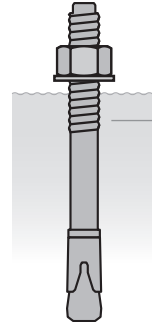
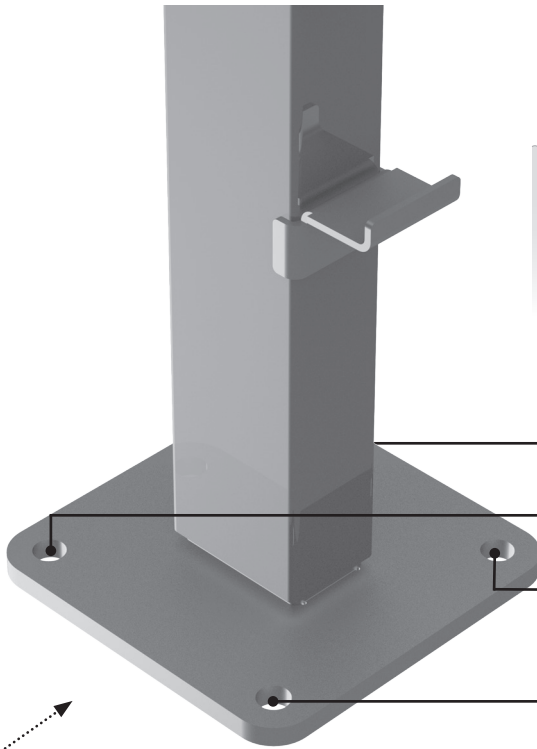
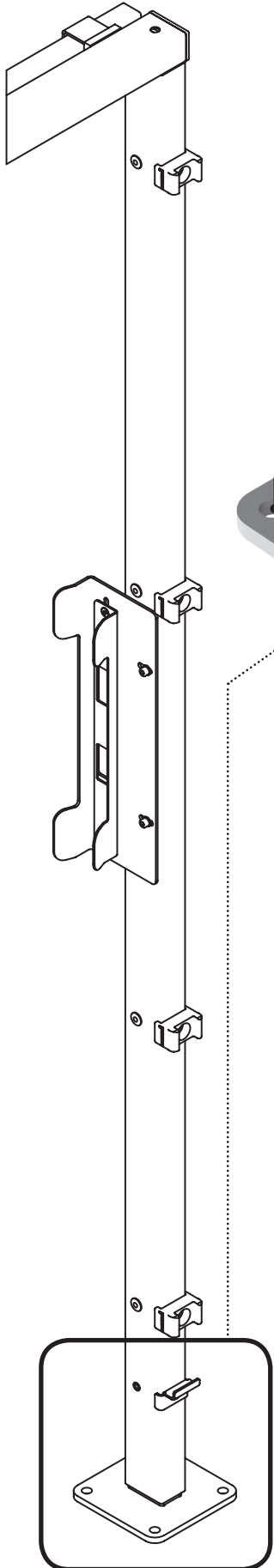

4 x  HSA M10x113 50/40/10

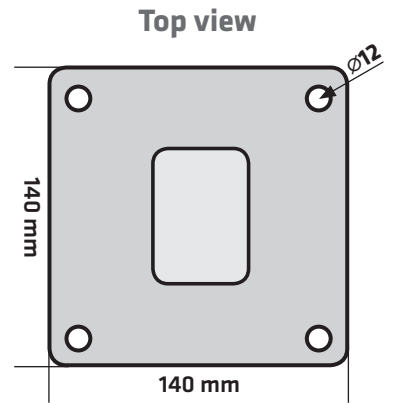

Technical data:

Dowel size	M10
Dowel length	113 mm
Approvals	ETA-11/0374
Substrate material	Concrete (uncracked) C20/25 - C50/60
Environmental factors	Indoors, dry
Edge clearance	50 mm
Operating principle	Torque-controlled expansion anchor
Standard embedment depth	50 mm
Nominal drill diameter	10 mm
Borehole depth	80 mm
Required tightening torque	25 Nm

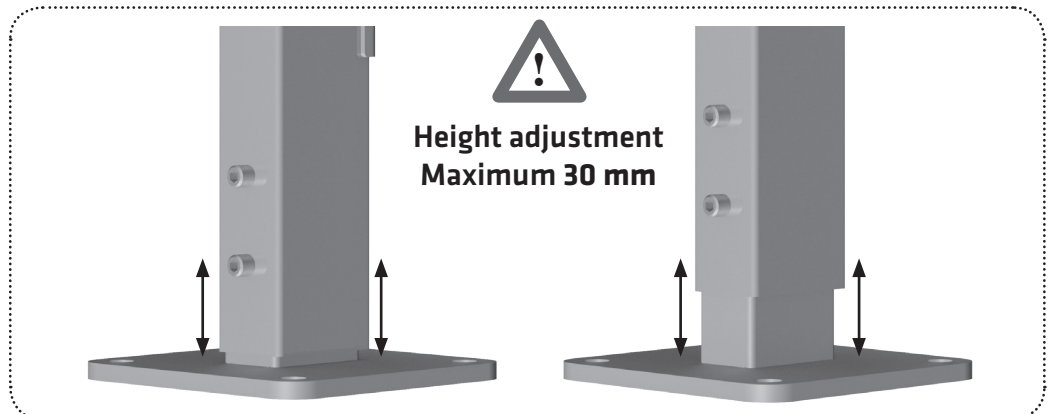

5.3. Interface for fixing locking devices 1-leaf sliding door, variant TS01, as a movable guard in connection with an on-site locking device



For the locking device (safety switch) to be fixed in place, threaded rivets can be set on the door leaf and post in the upper area of the inner side of the door (see illustration below, area marked grey).

 Should you have any further questions, please contact us on +49 (0) 5223 791995-0.

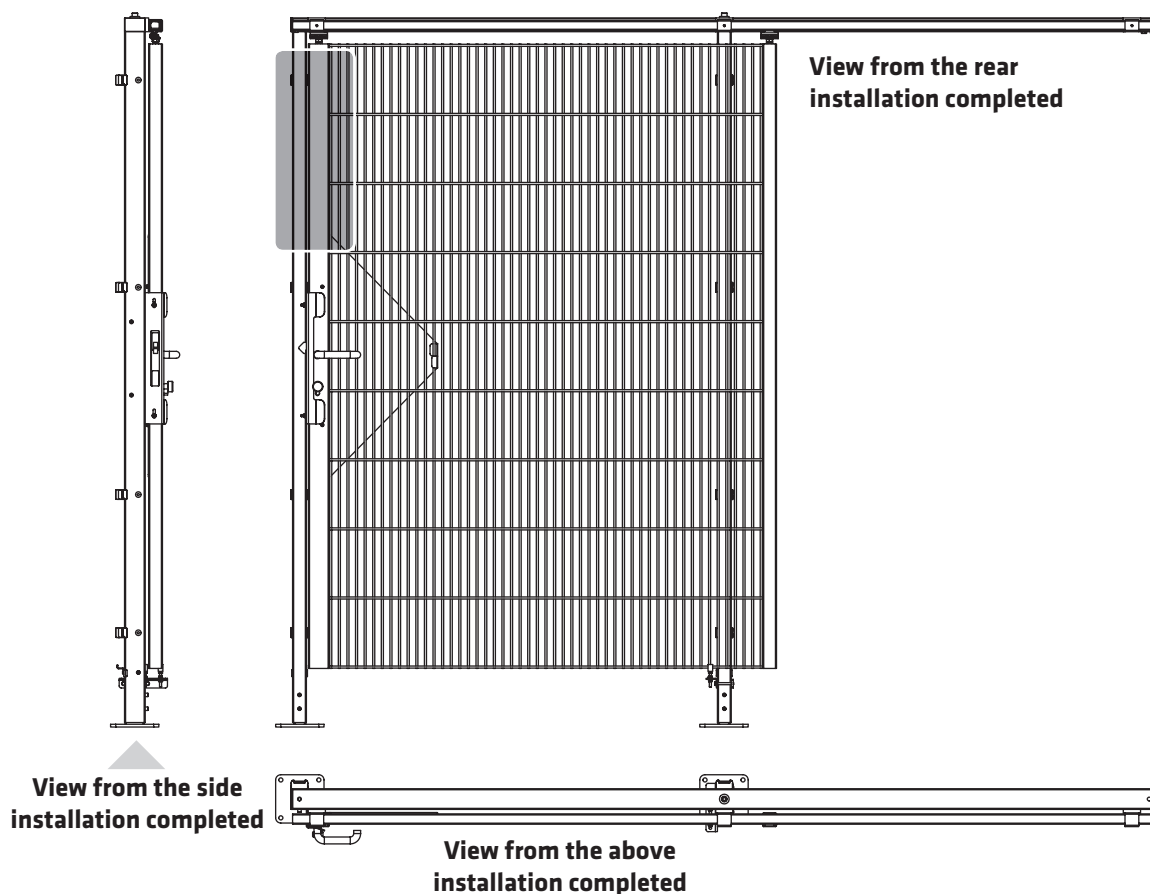
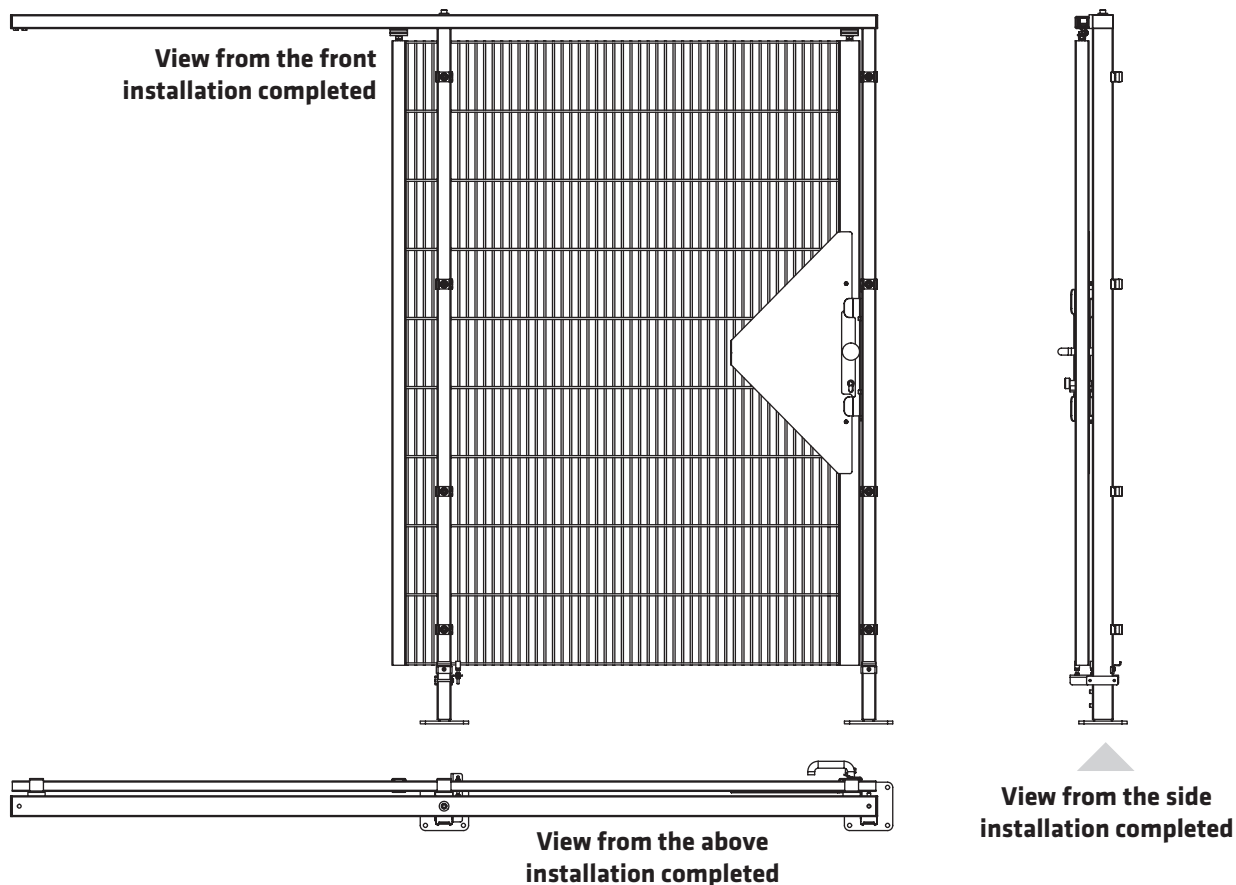

5.4. Installation of 1-leaf sliding door
Installation version DIN LEFT / installation height 2053 mm

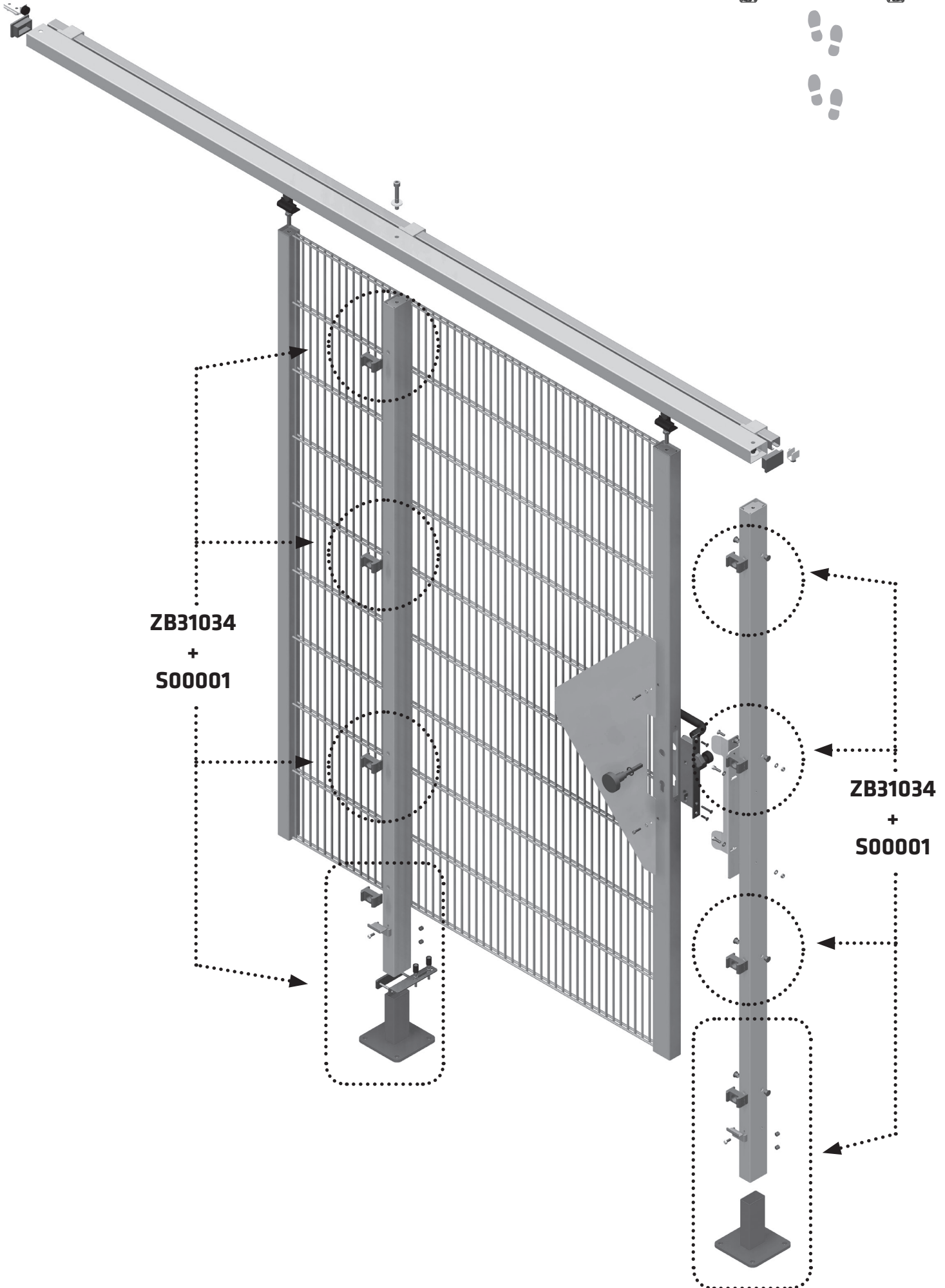
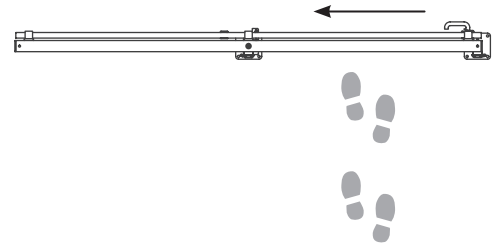

5.4. Installation of 1-leaf sliding door

Installation version DIN LEFT / installation height 2053 mm



See page 9

View from the front

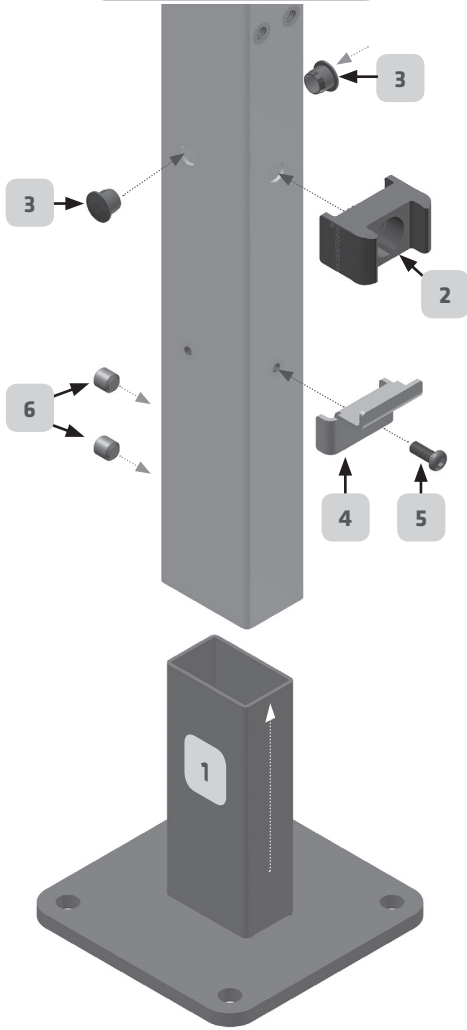

View from the rear

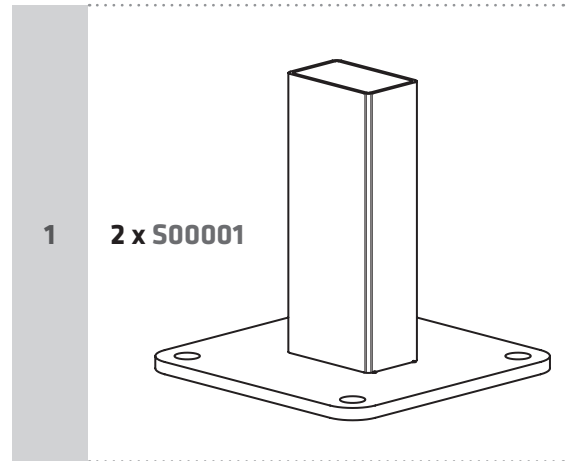
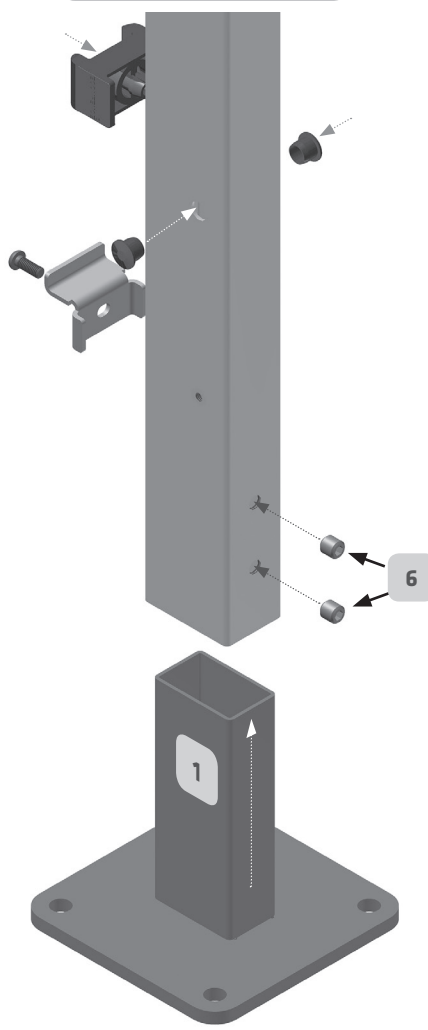

2 x ZB31034

2	4 x ZB21008	
3	8 x ZB20018	
4	1 x VA-B00024	
5	1 x ISO 7380 M6x16	
6	2 x DIN913 M10x10	
For installation height 2253 mm use 2 x ZB31035.		

View with installation completed

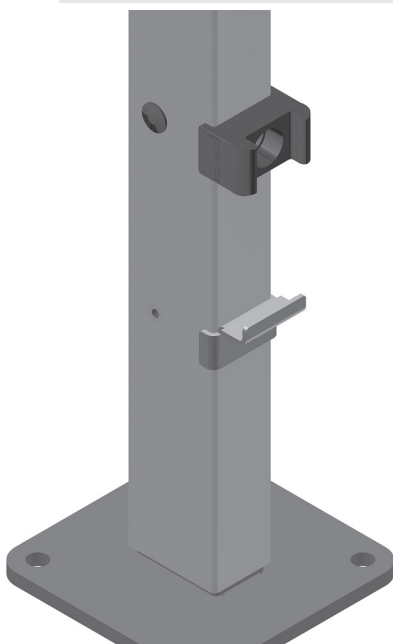

View from the front

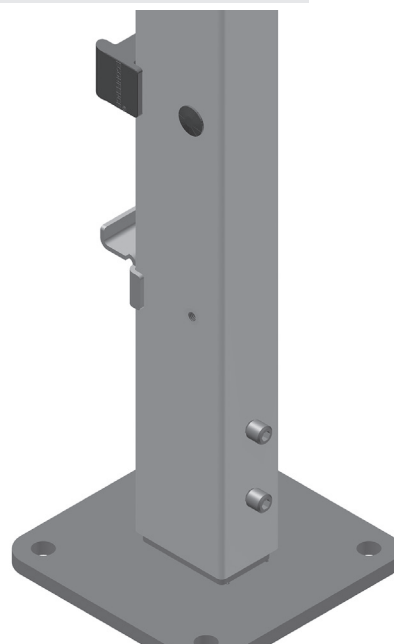

View from the rear

5.4. Installation of 1-leaf sliding door
Installation version DIN LEFT / installation height 2053 mm

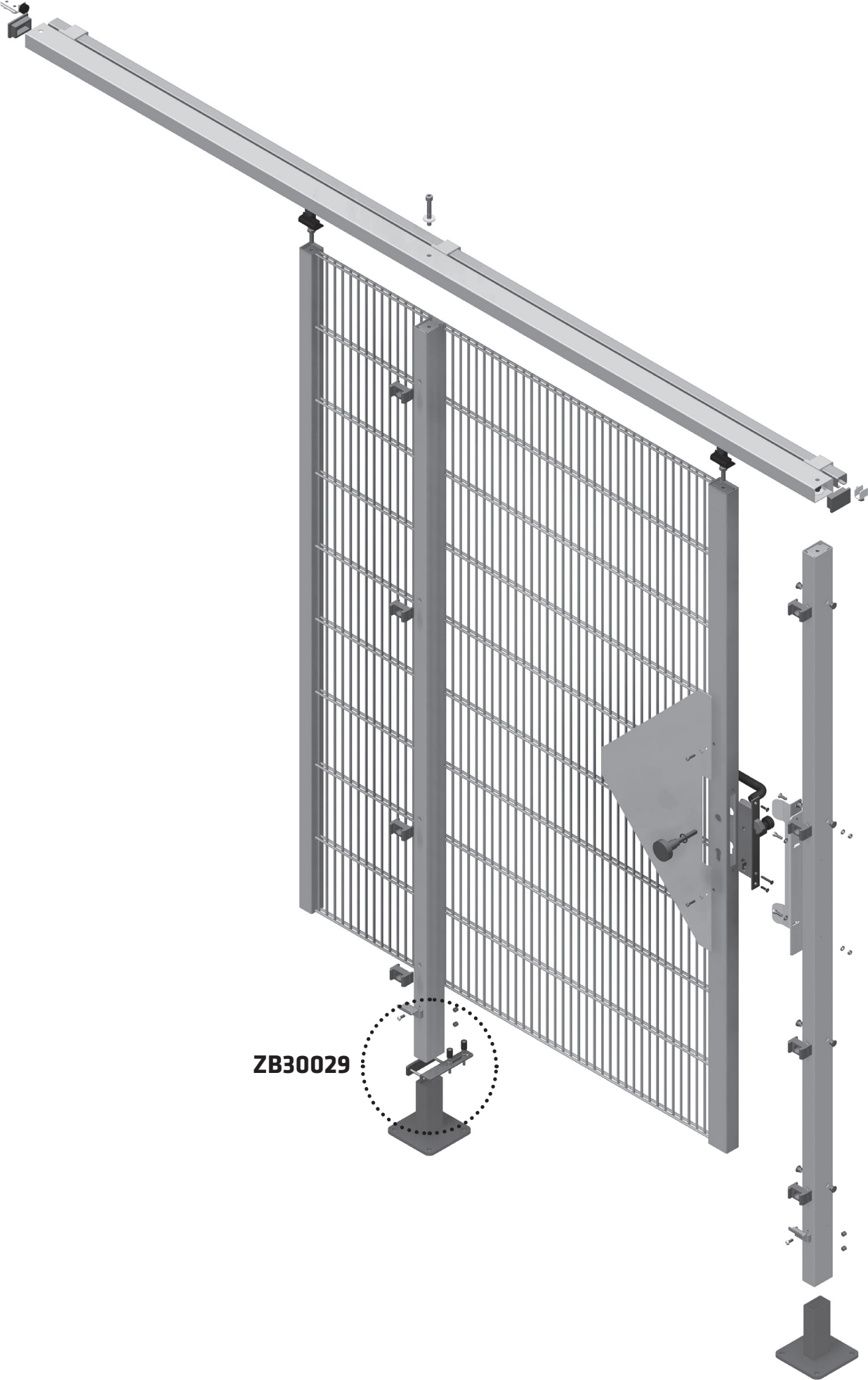
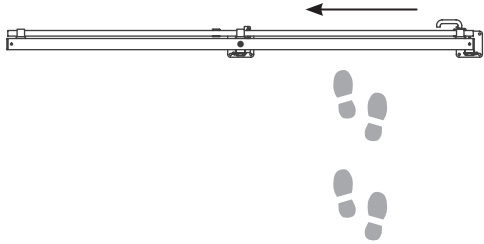

ZB30029

5.4. Installation of 1-leaf sliding door
Installation version DIN LEFT / installation height 2053 mm



See page 9

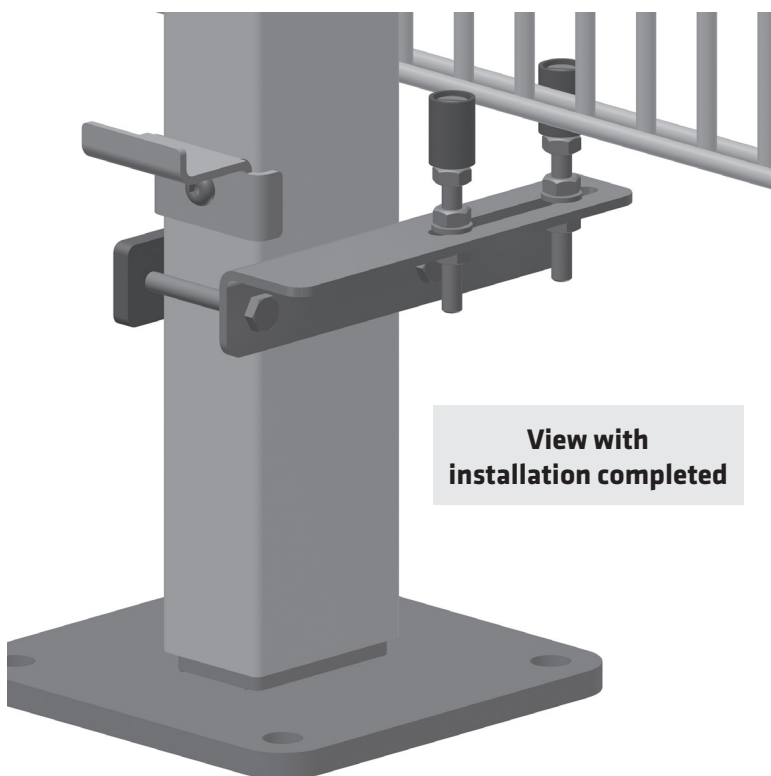
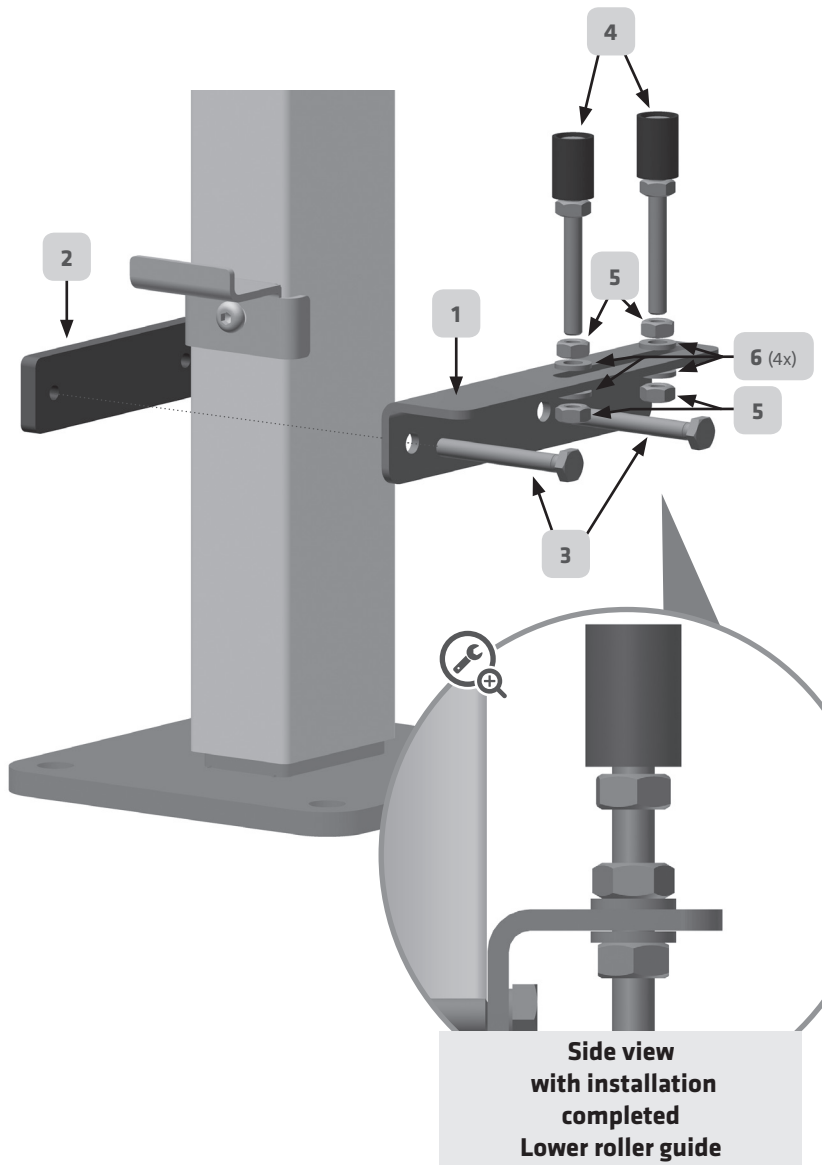

ZB30029		
1	1 x B00007	
2	1 x F00008	
3	2 x DIN933-8,8-M6x50	
4	2 x roller	
5	4 x DIN934-M6	
6	4 x DIN125-8,8-A6,4	

5.4. Installation of 1-leaf sliding door
Installation version DIN LEFT / installation height 2053 mm

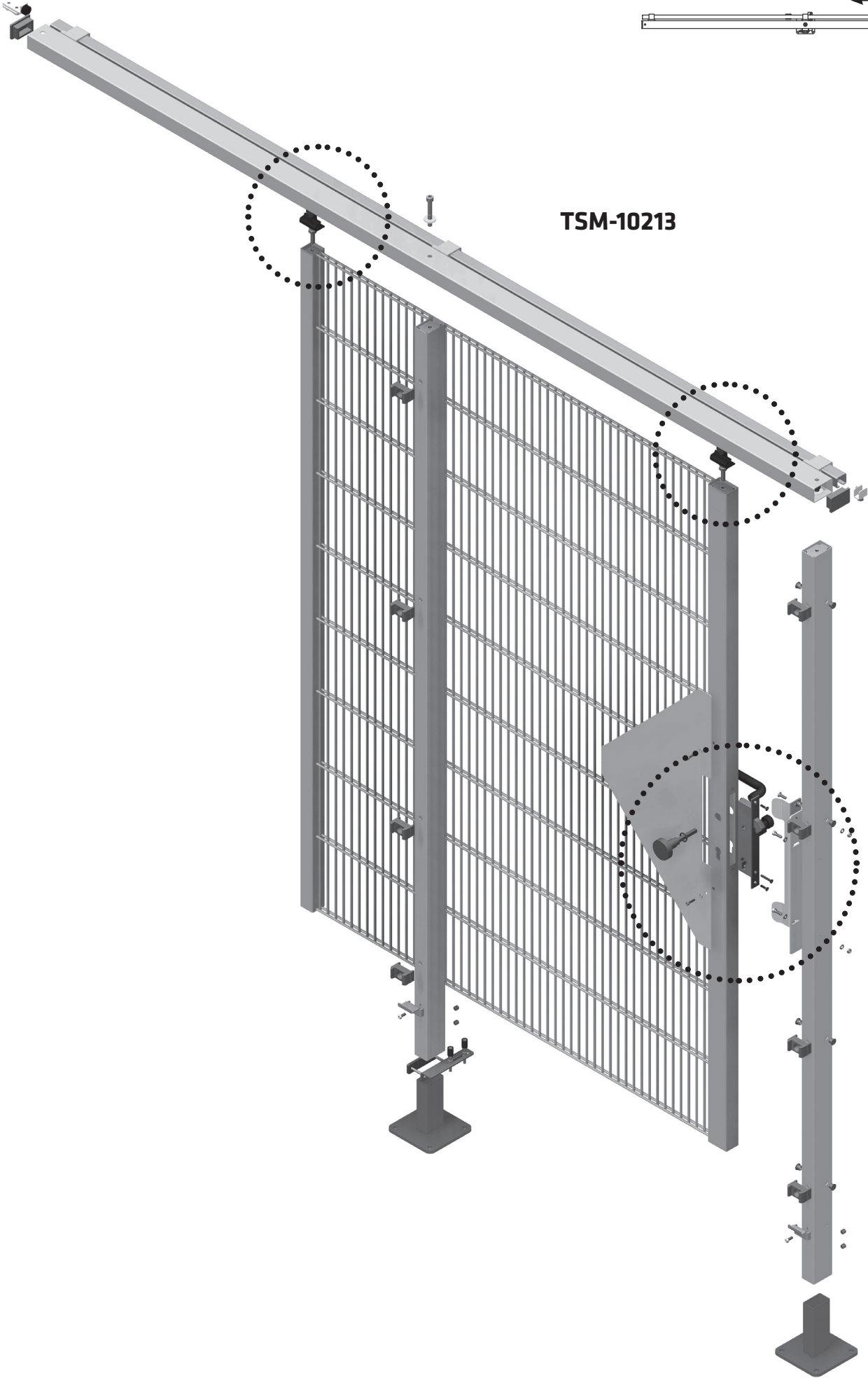
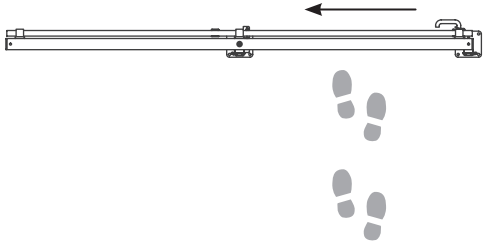

5.4. Installation of 1-leaf sliding door

Installation version DIN LEFT / installation height 2053 mm



See page 9

TSM-10213

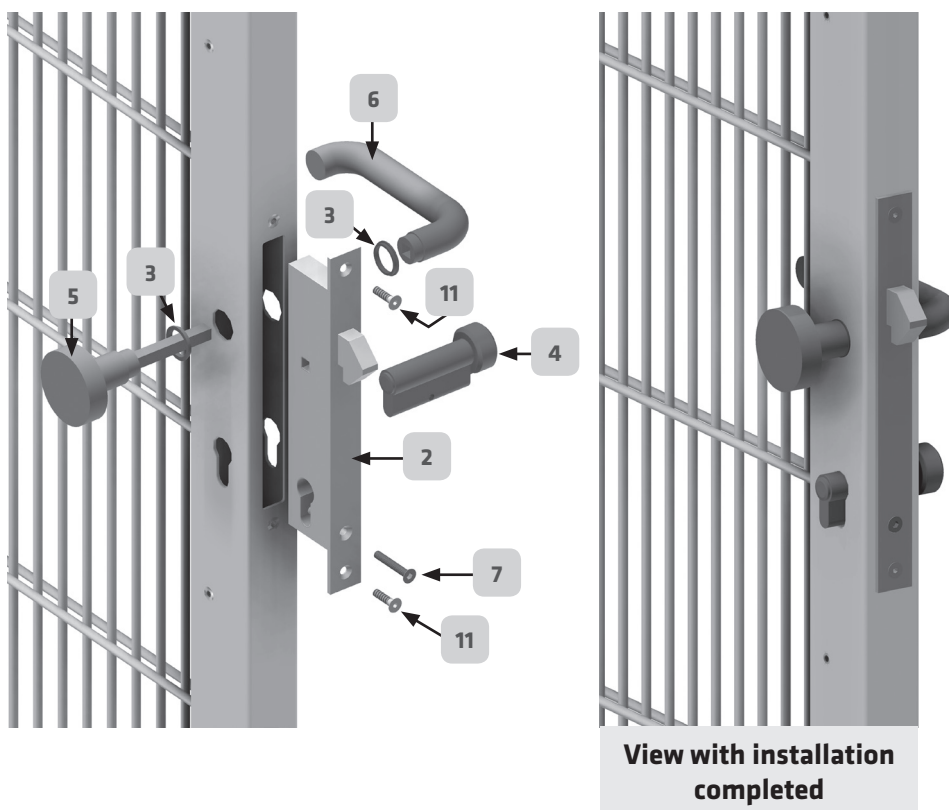
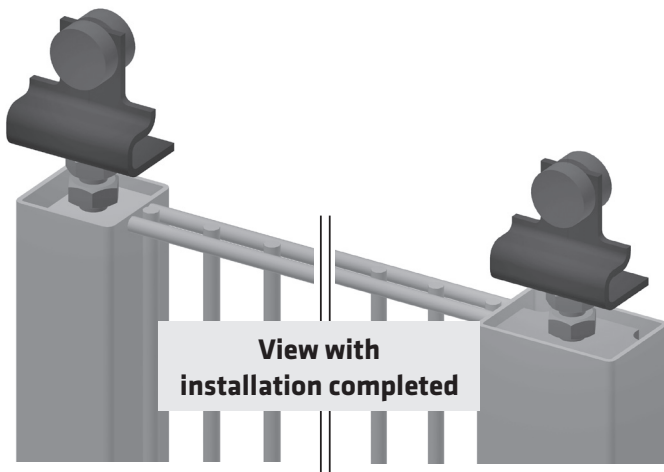
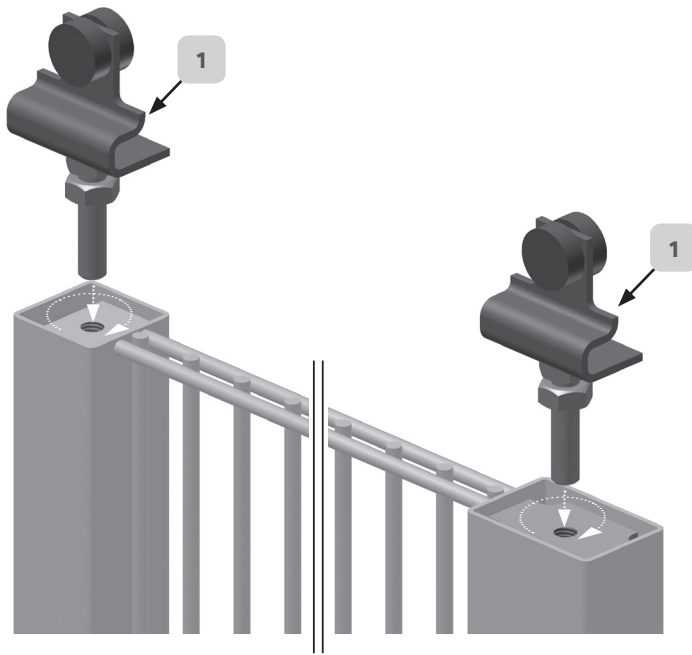

1 2 x ZB20061

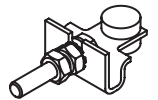

2 1 x ZB10102

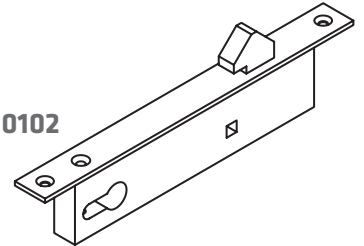

3 2 x ZB20043



4 1 x TSB-10271

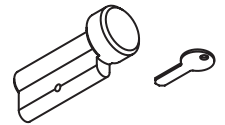

5 1 x ZB10035

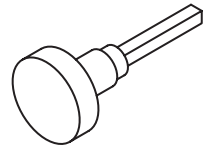

6 1 x ZB10035:2

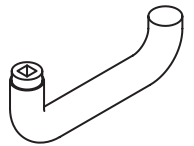

7 1 x DIN 7991-8.8-M5x35



8 1 x B00014

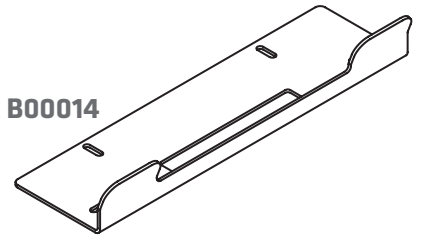

9 1 x B00012

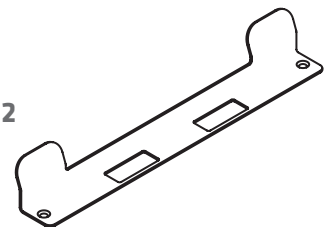

10 4 x DIN 125-8.8-A6.4



11 2 x DIN 7991-M5x20



12 2 x DIN 7991-M6x20



13 2 x DIN 912-8.8-M6x20



14 2 x DIN 934-8.8-M6



5.4. Installation of 1-leaf sliding door
Installation version DIN LEFT / installation height 2053 mm

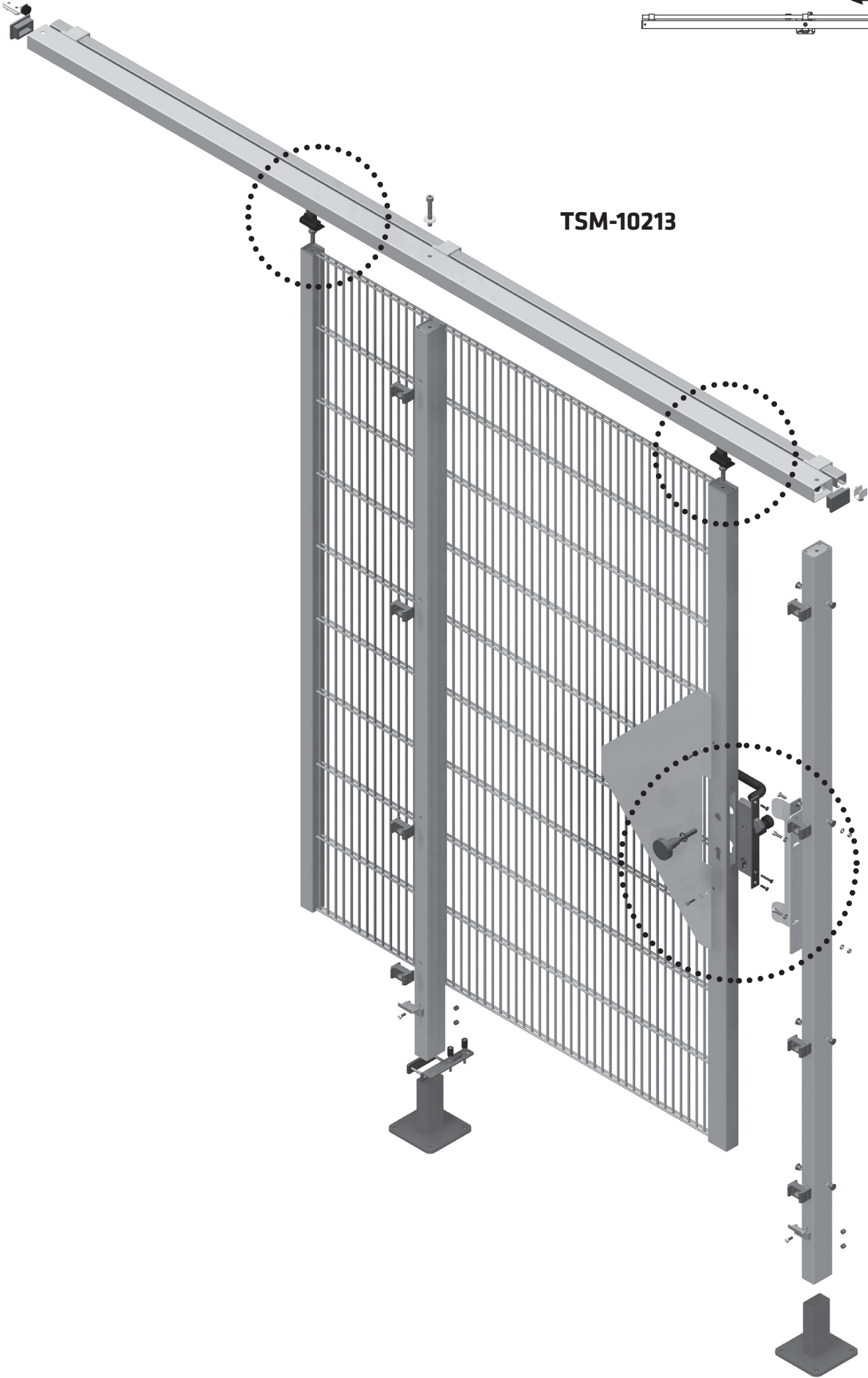
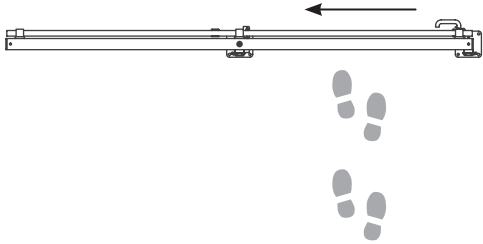

TSM-10213

5.4. Installation of 1-leaf sliding door
Installation version DIN LEFT / installation height 2053 mm



See page 9

TSM-10213

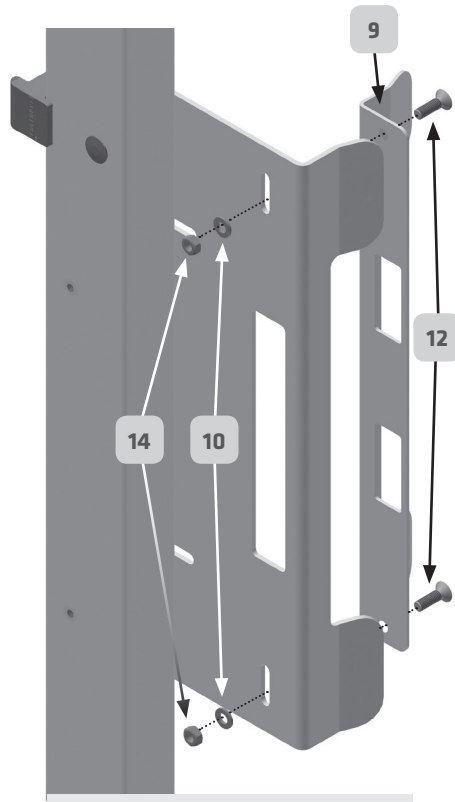
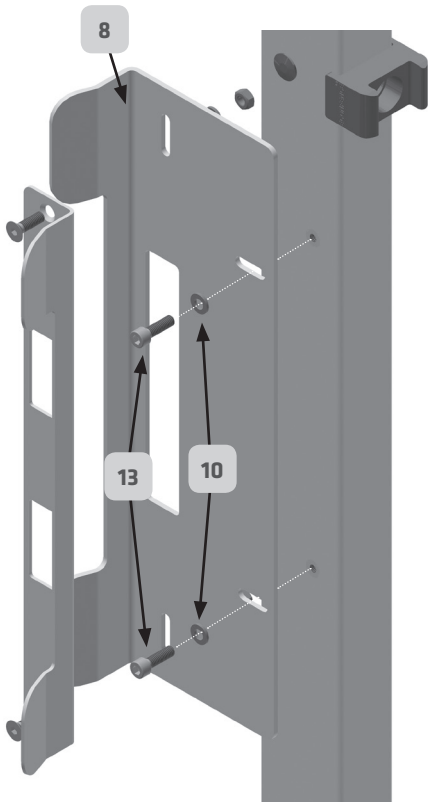

View from the rear

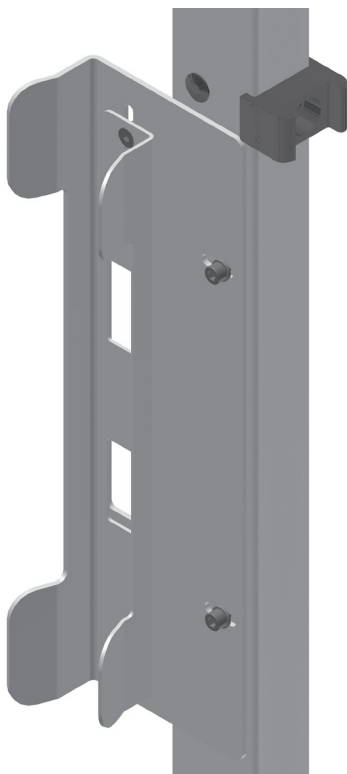

View with installation completed

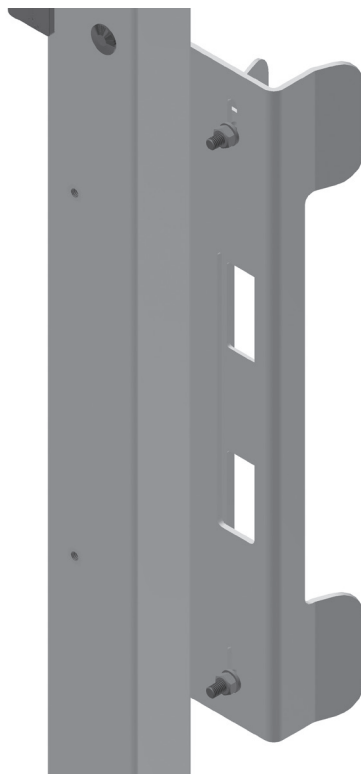

View from the rear with installation completed

1 2 x ZB20061

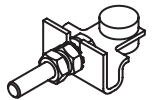

2 1 x ZB10102

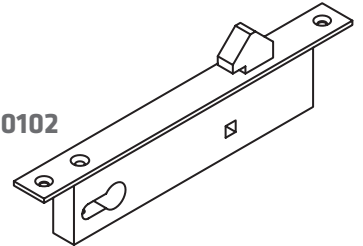

3 2 x ZB20043



4 1 x TSB-10271

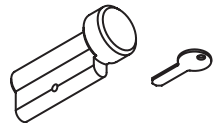

5 1 x ZB10035

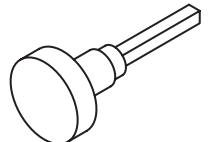

6 1 x ZB10035:2

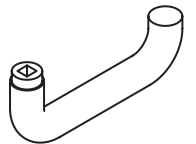

7 1 x DIN 7991-8.8-M5x35



8 1 x B00014

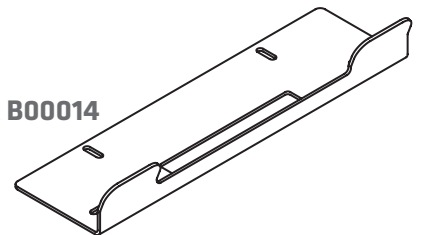

9 1 x B00012

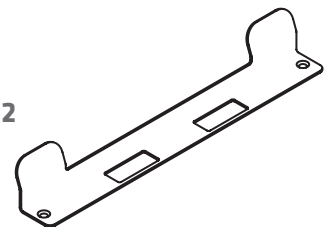

10 4 x DIN 125-8.8-A6.4



11 2 x DIN 7991-M5x20



12 2 x DIN 7991-M6x20



13 2 x DIN 912-8.8-M6x20



14 2 x DIN 934-8,8-M6



5.4. Installation of 1-leaf sliding door
Installation version DIN LEFT / installation height 2053 mm

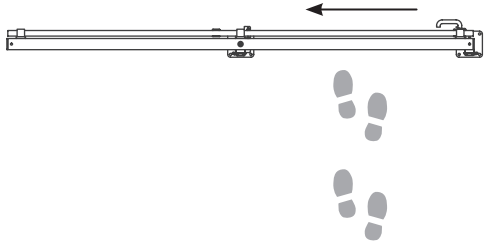

B00024

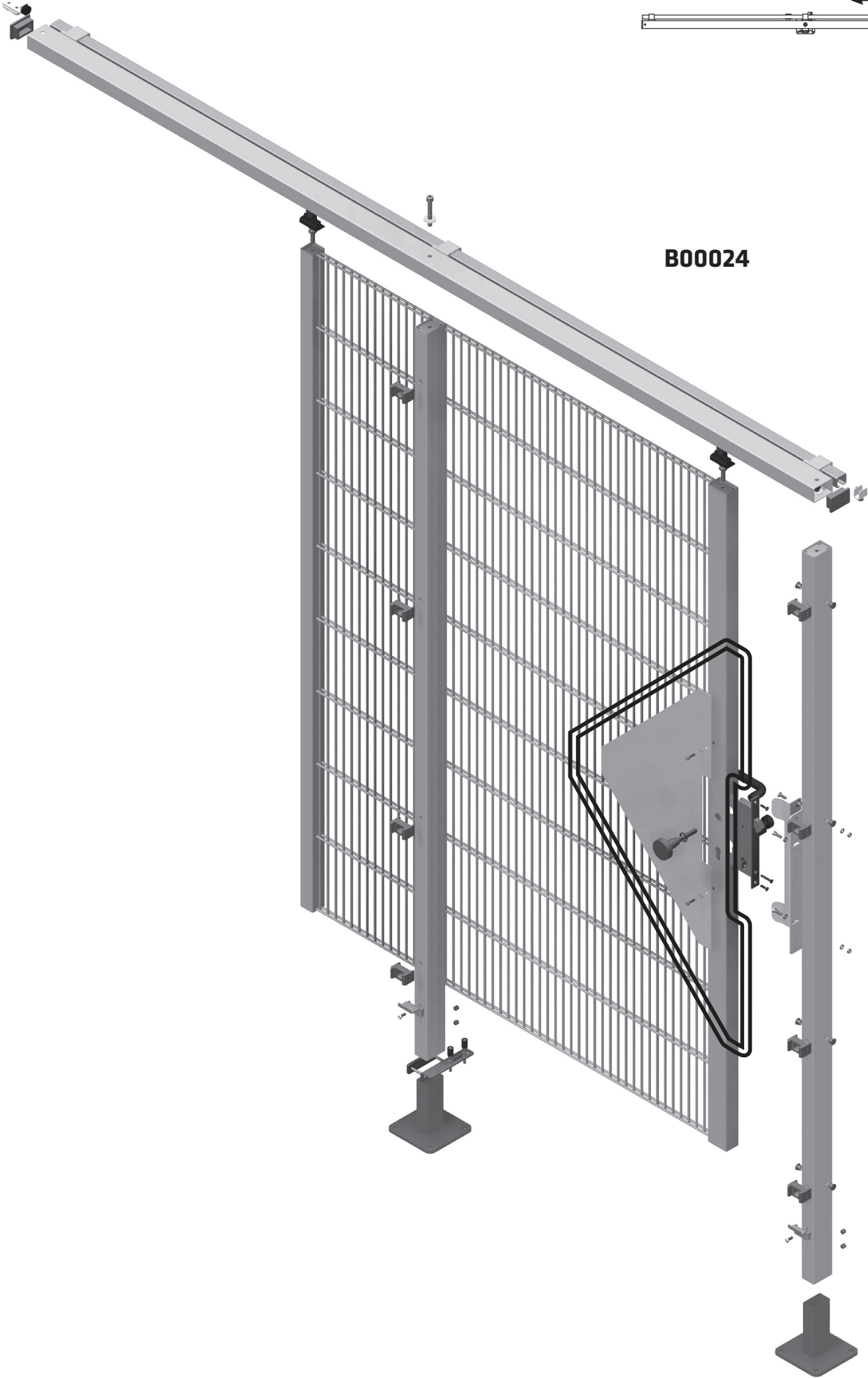

5.4. Installation of 1-leaf sliding door
Installation version DIN LEFT / installation height 2053 mm



See page 9

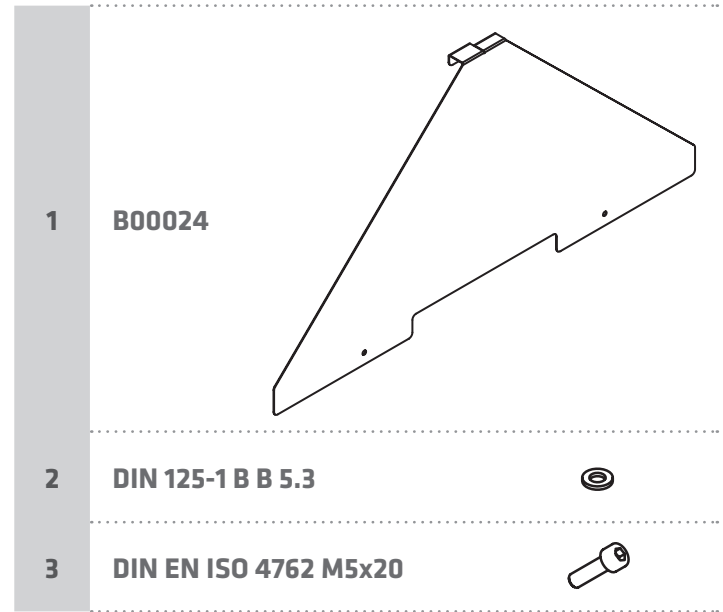

← **View with installation completed**

5.4. Installation of 1-leaf sliding door
Installation version DIN LEFT / installation height 2053 mm

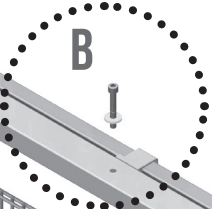
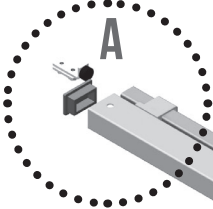
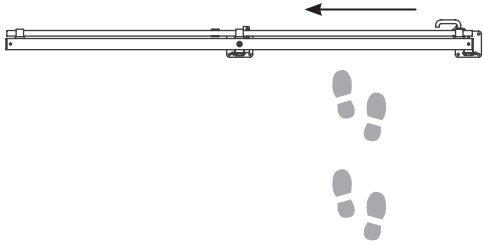

ZB31078

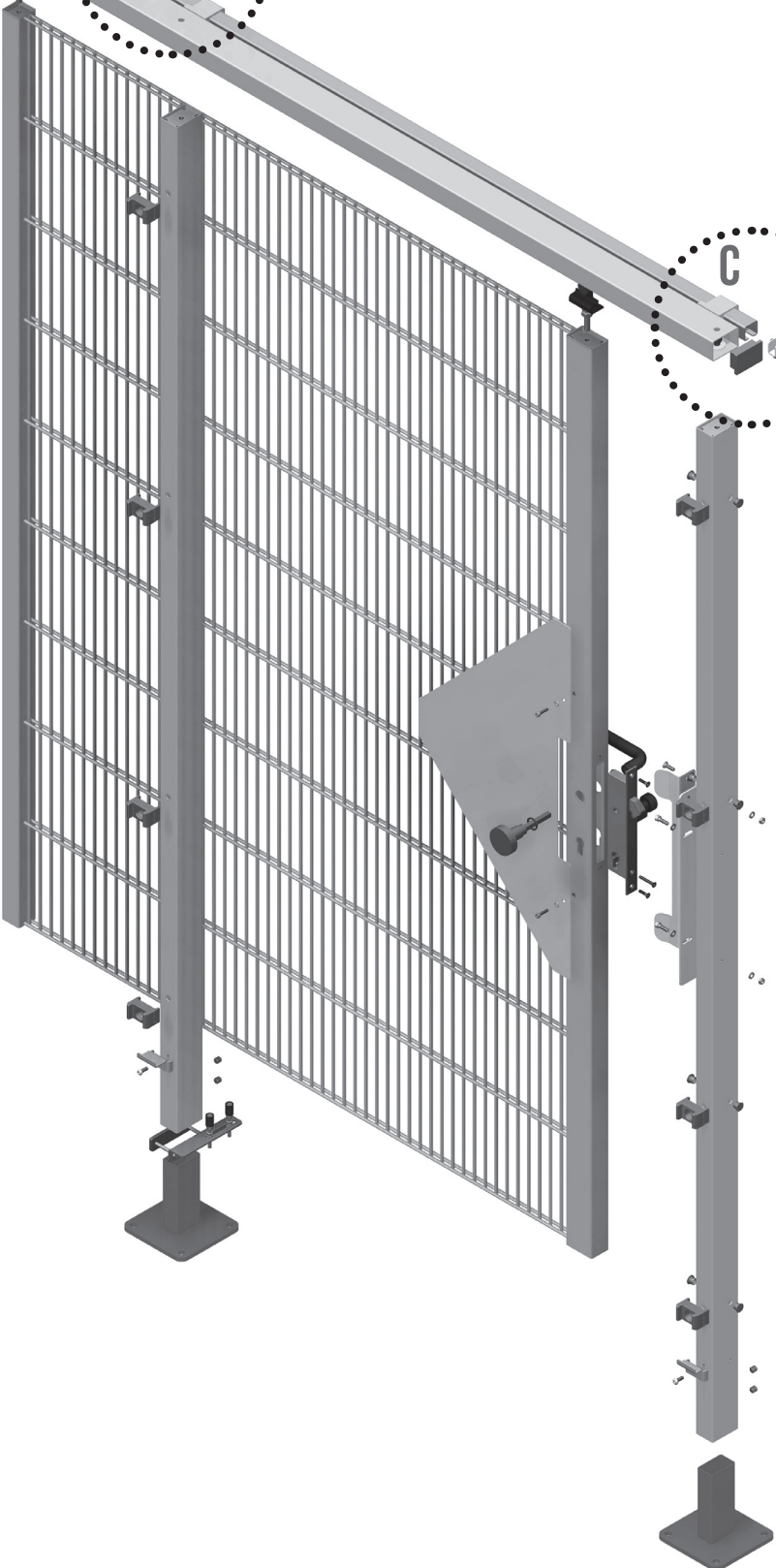
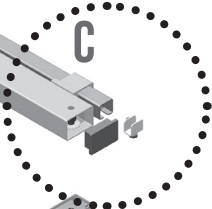

5.4. Installation of 1-leaf sliding door
Installation version DIN LEFT / installation height 2053 mm



See page 9

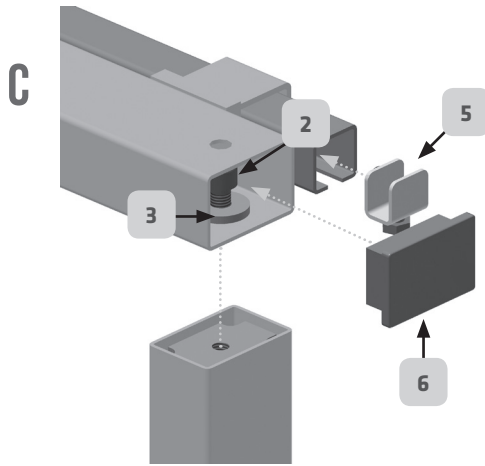
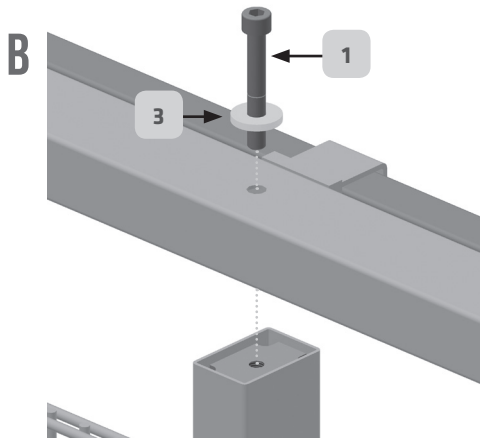
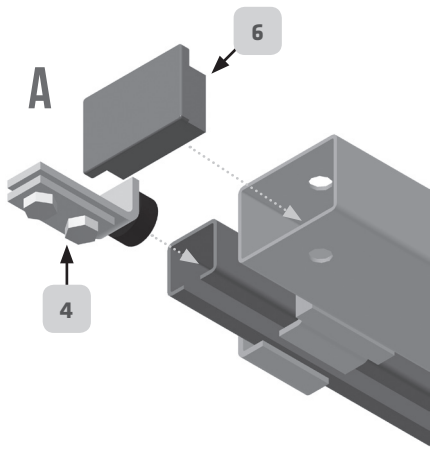

ZB31078		
1	1 x DIN912-8,8-M10x70	
2	1 x DIN912-8.8-M10x20	
3	2 x DIN6340-10,5x28x4	
4	1 x ZB20070	
5	1 x ZB20071	
6	2 x ZB20096	

View with installation completed

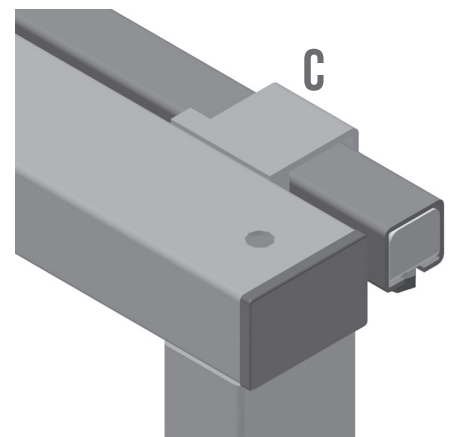
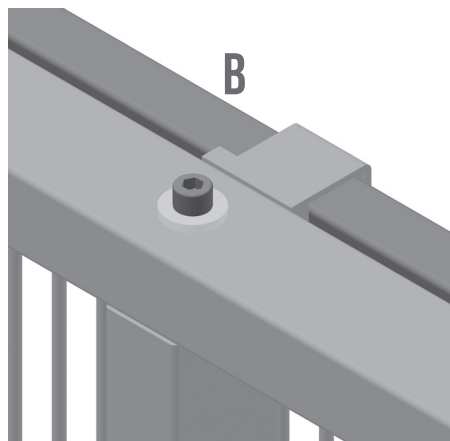
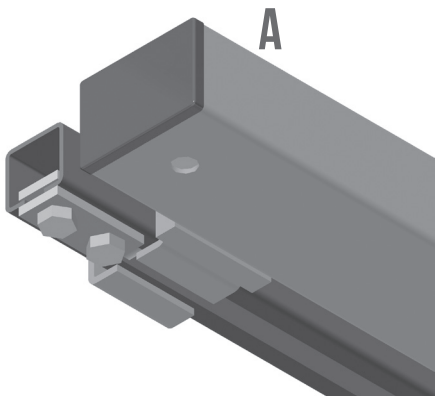

5.4. Installation of 1-leaf sliding door Installation version DIN RIGHT / installation height 2053 mm

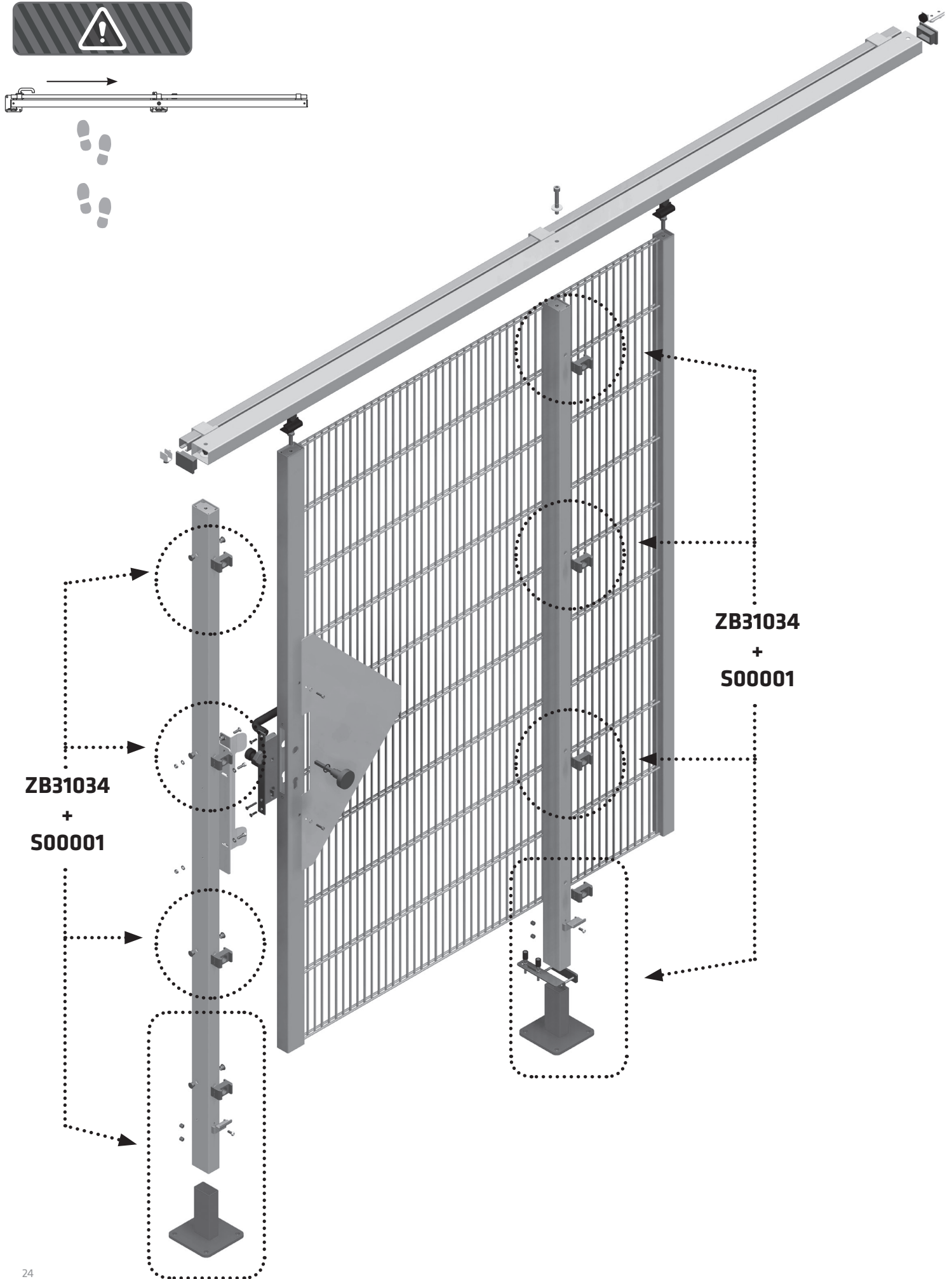

5.4. Installation of 1-leaf sliding door
Installation version DIN RIGHT / installation height 2053 mm



See page 9

View from the rear

View from the front

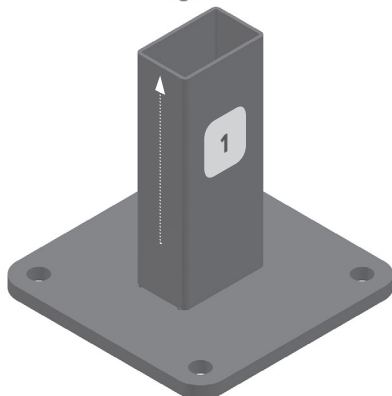
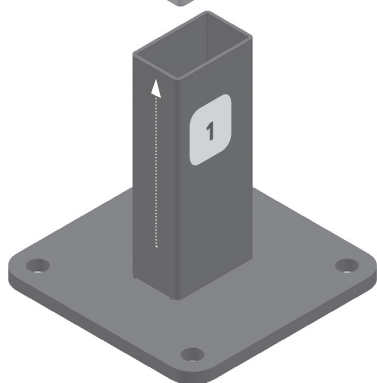
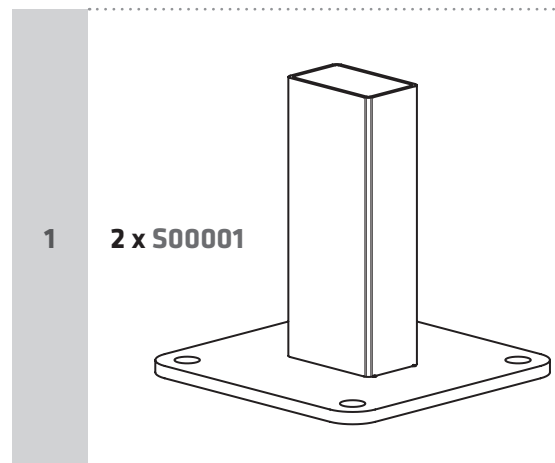
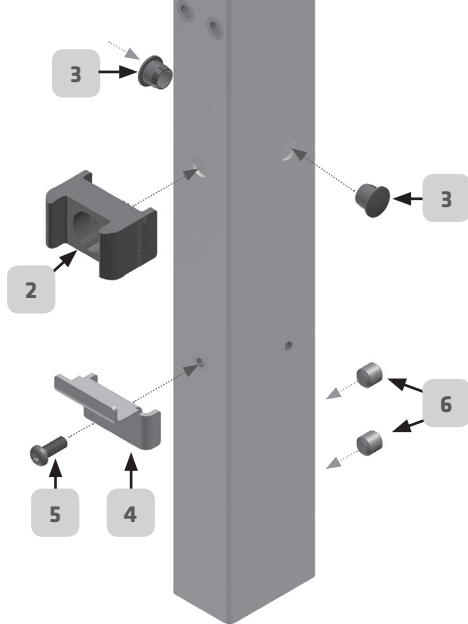
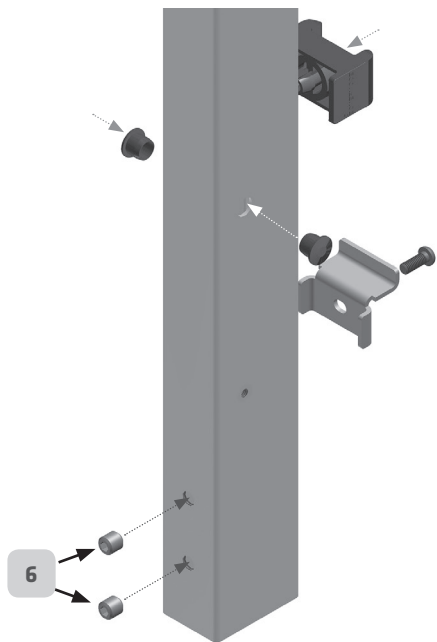

View with installation completed

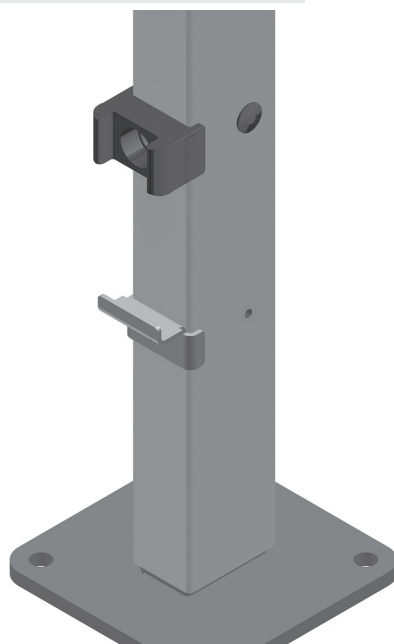
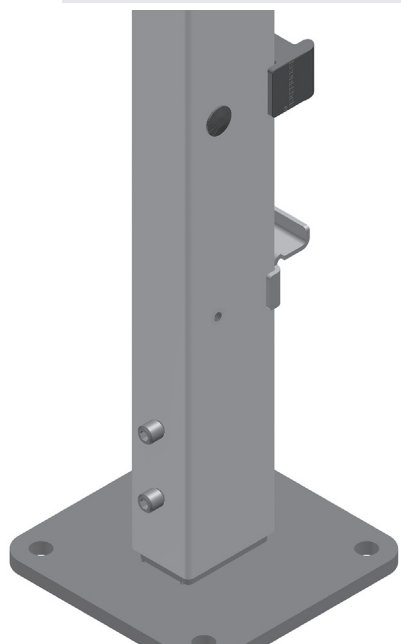

View from the rear

View from the front

2 x ZB31034		
2	4 x ZB21008	
3	8 x ZB20018	
4	1 x VA-B00024	
5	1 x ISO 7380 M6x16	
6	2 x DIN913 M10x10	
For installation height 2253 mm use 2 x ZB31035.		

5.4. Installation of 1-leaf sliding door
Installation version DIN RIGHT / installation height 2053 mm

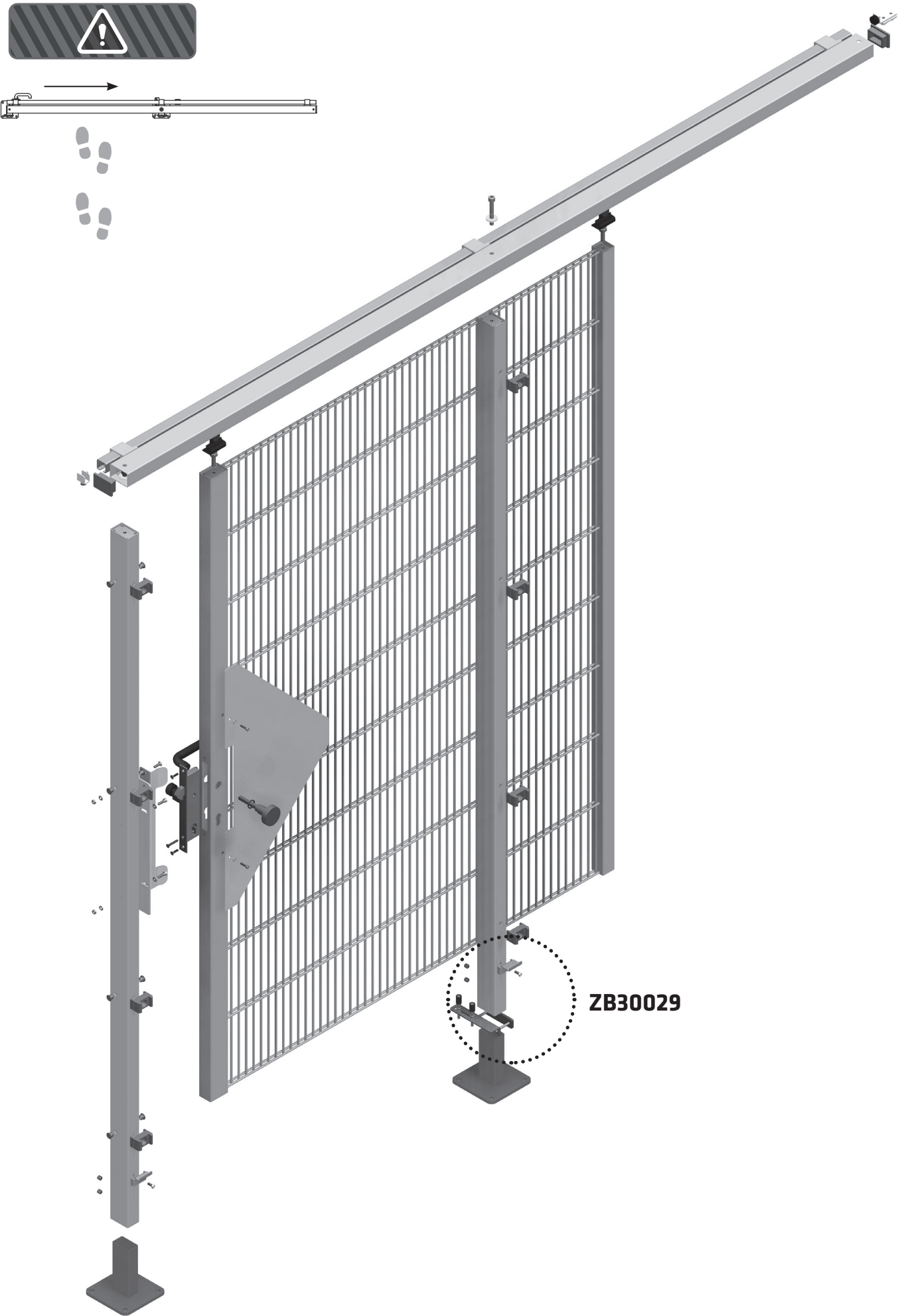



5.4. Installation of 1-leaf sliding door
Installation version DIN RIGHT / installation height 2053 mm

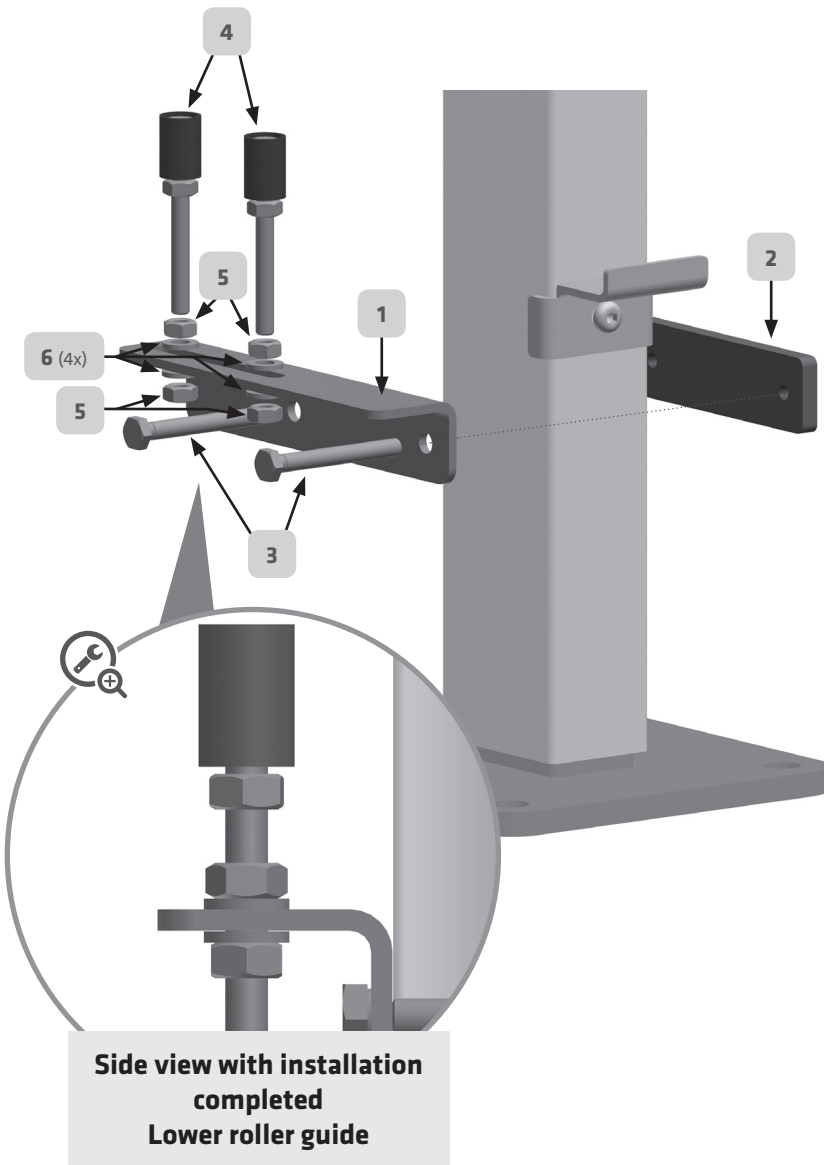

See page 9

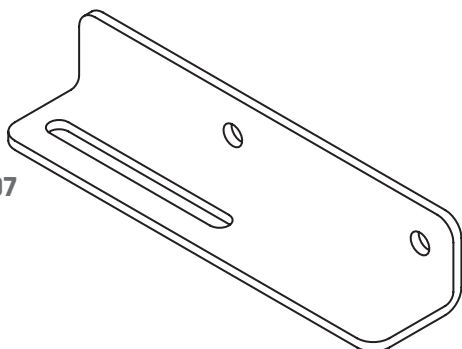
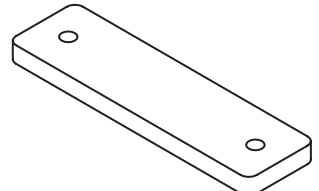
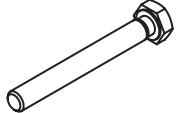
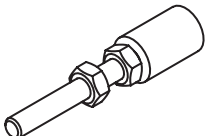

ZB30029	
1	1 x B00007 
2	1 x F00008 
3	2 x DIN933-8,8-M6x50 
4	2 x roller 
5	4 x DIN934-M6 
6	4 x DIN125-8,8-A6,4 

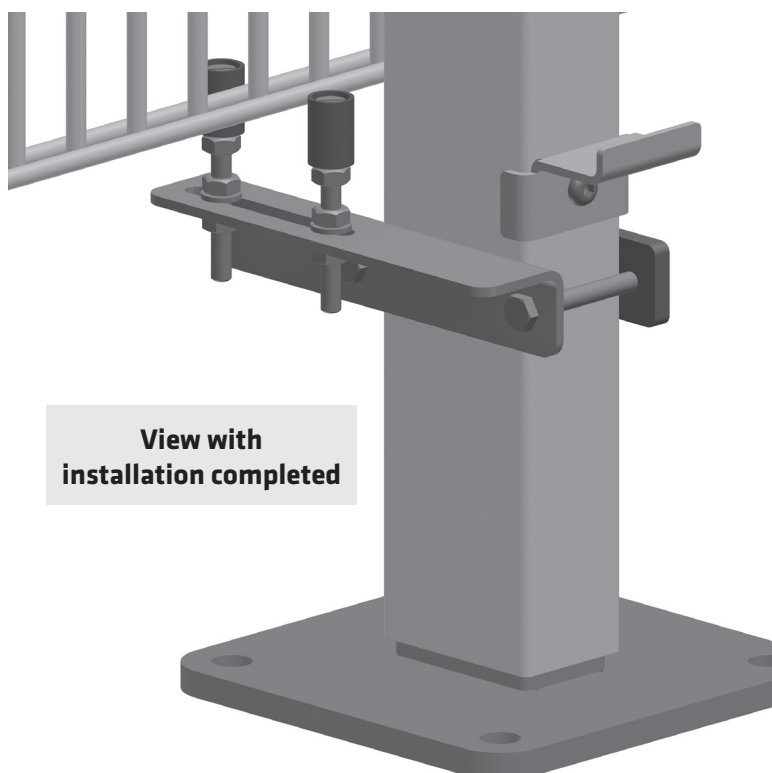

5.4. Installation of 1-leaf sliding door
Installation version DIN RIGHT / installation height 2053 mm

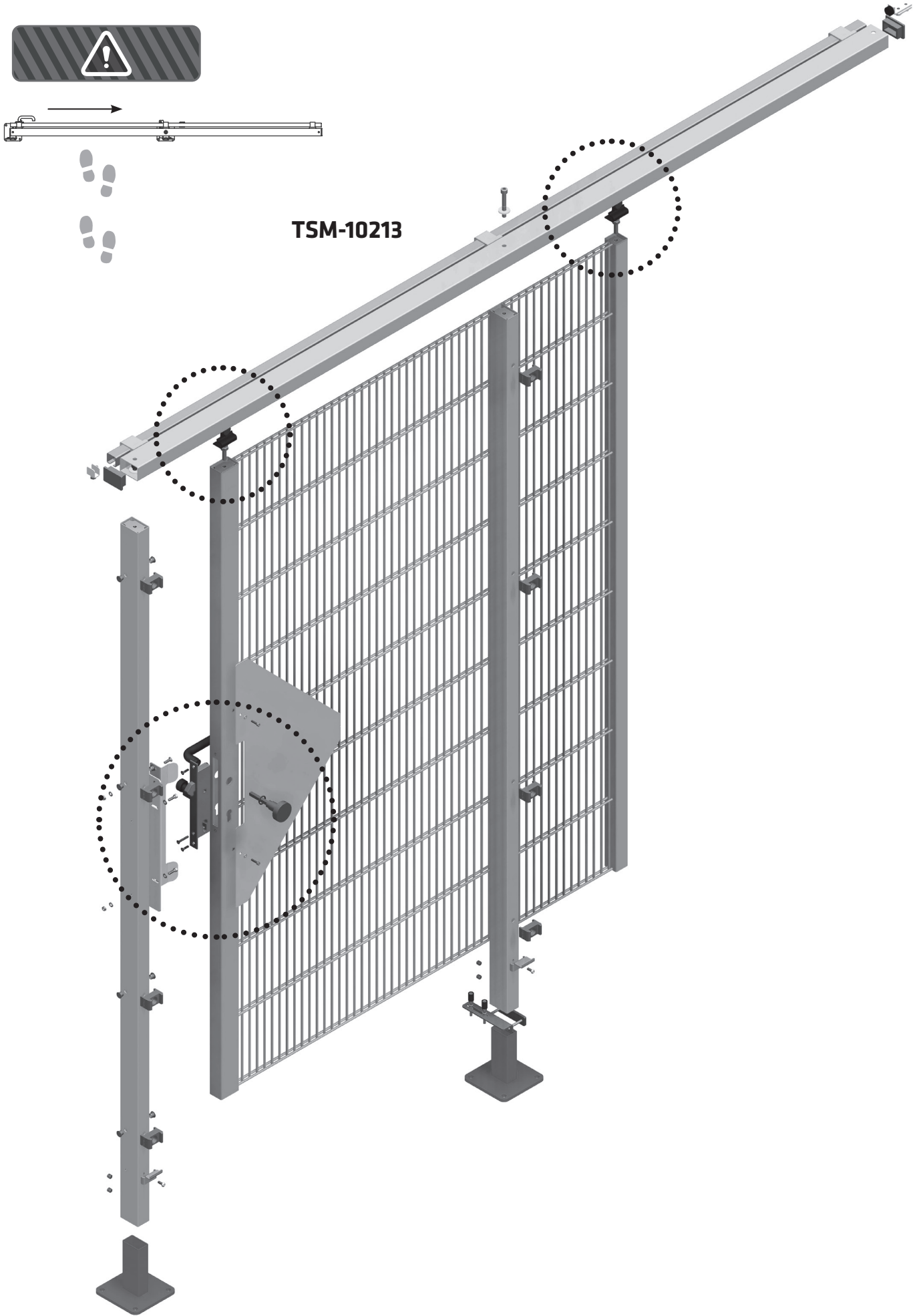

5.4. Installation of 1-leaf sliding door
Installation version DIN RIGHT / installation height 2053 mm



See page 9

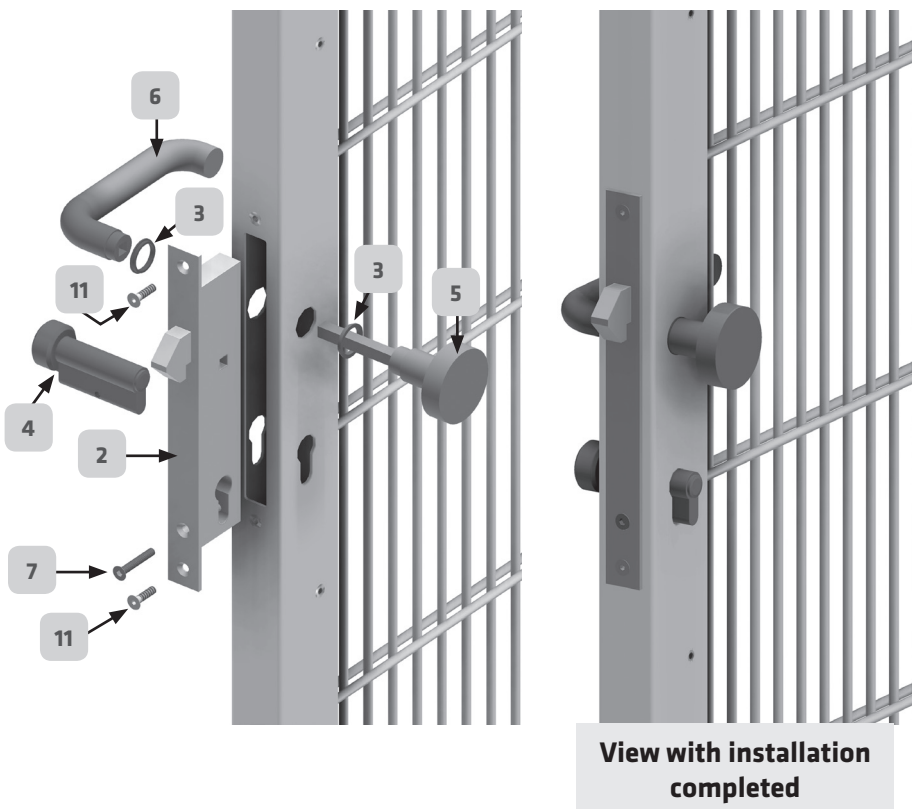
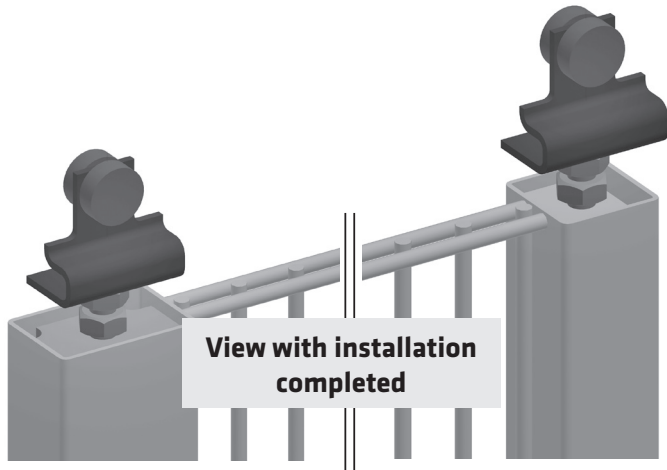
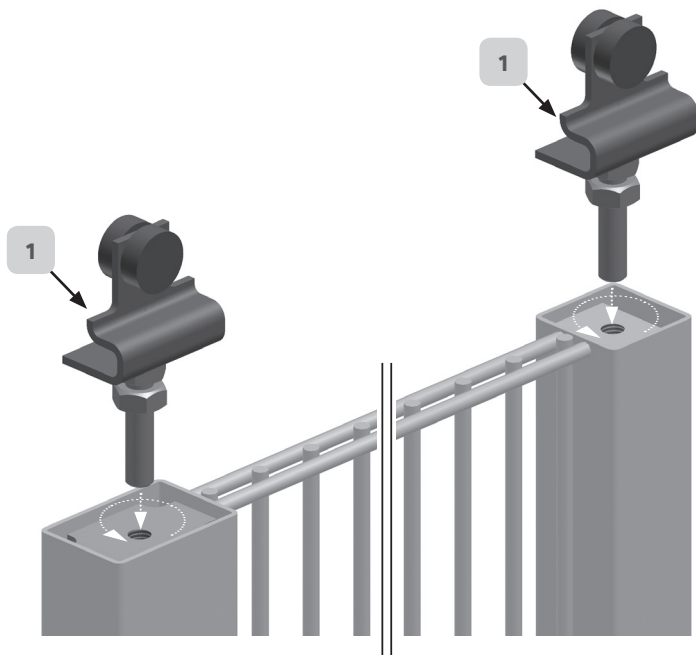

TSM-10213		
1	2 x ZB20061	
2	1 x ZB10102	
3	2 x ZB20043	
4	1 x TSB-10271	
5	1 x ZB10035	
6	1 x ZB10035:2	
7	1 x DIN 7991-8.8-M5x35	
8	1 x B00014	
9	1 x B00012	
10	4 x DIN 125-8.8-A6.4	
11	2 x DIN 7991-M5x20	
12	2 x DIN 7991-M6x20	
13	2 x DIN 912-8,8-M6x20	
14	2 x DIN 934-8,8-M6	

5.4. Installation of 1-leaf sliding door
Installation version DIN RIGHT / installation height 2053 mm



TSM-10211

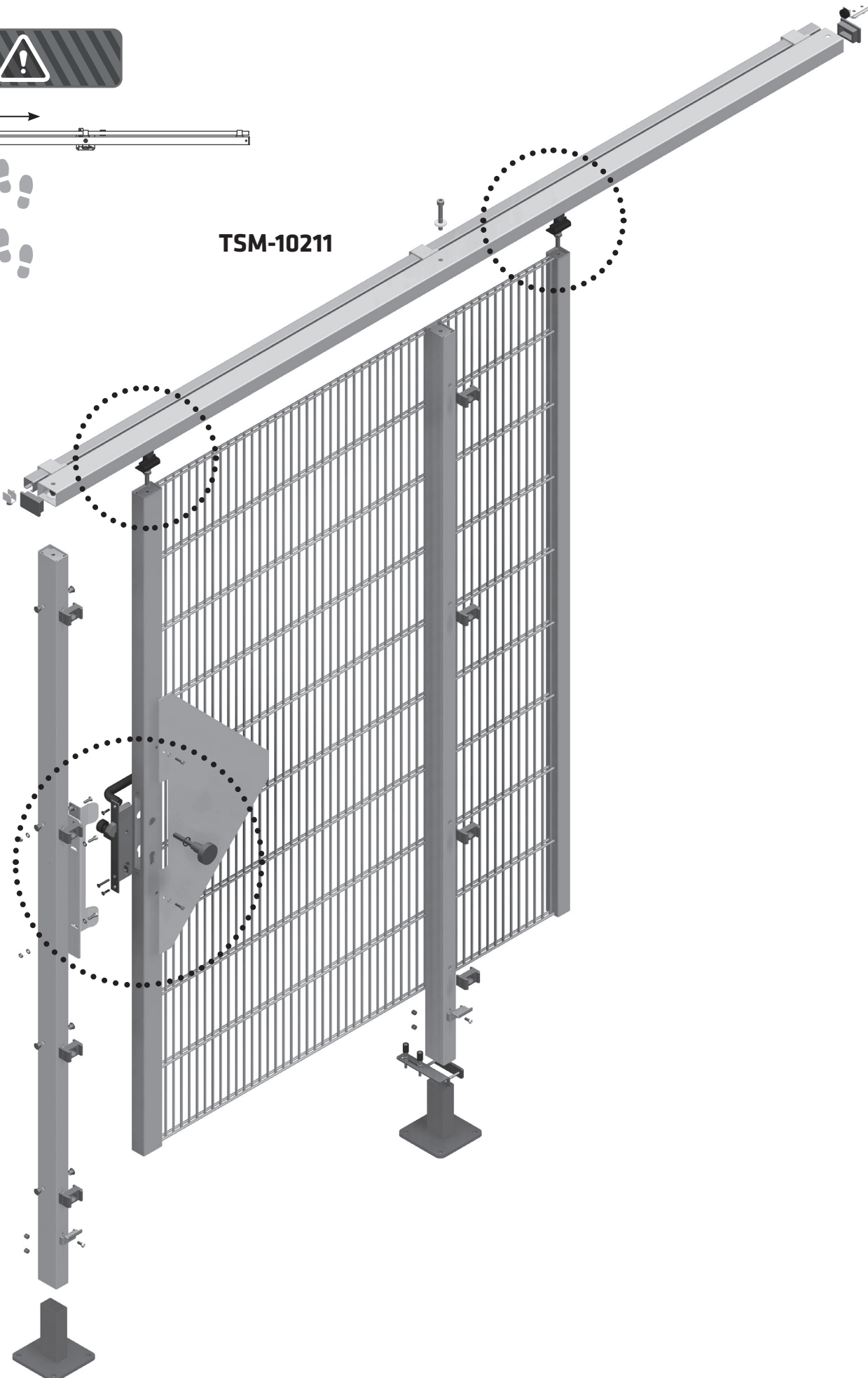

5.4. Installation of 1-leaf sliding door

Installation version DIN RIGHT / installation height 2053 mm



See page 9

TSM-10213

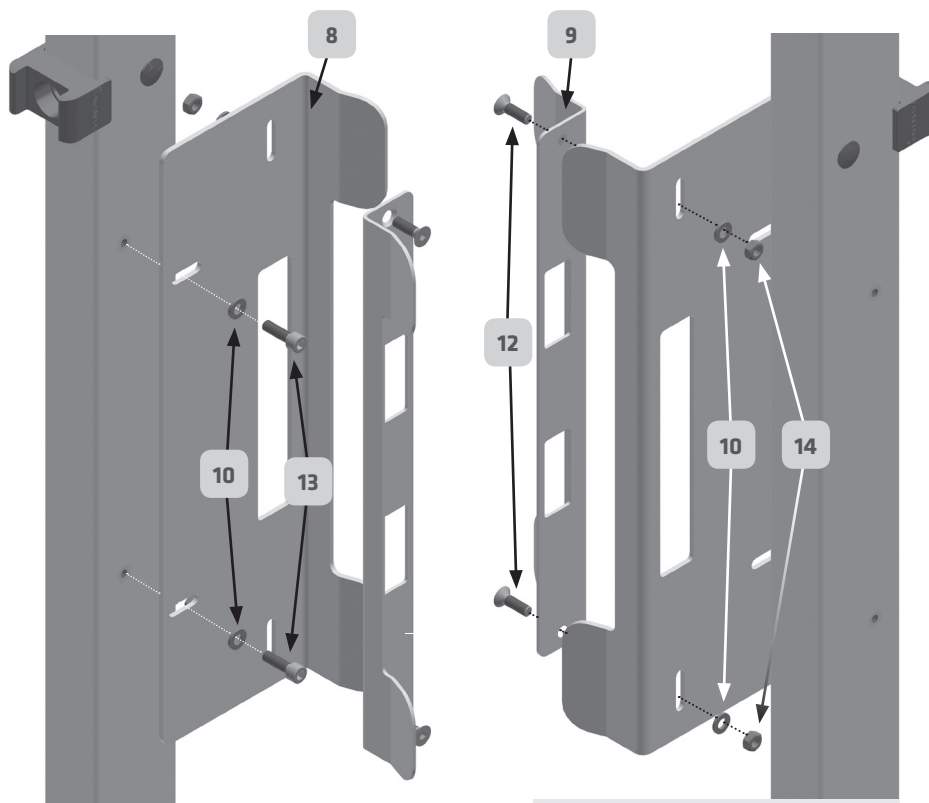

View from the rear

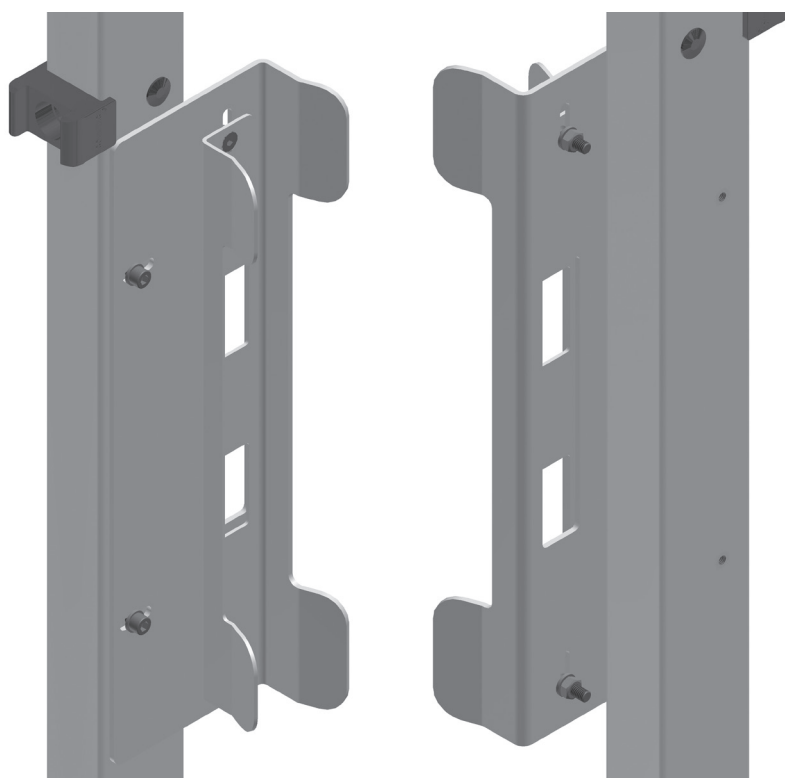

View with installation completed

View from the rear with installation completed

1 2 x ZB20061

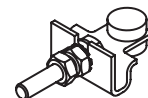

2 1 x ZB10102

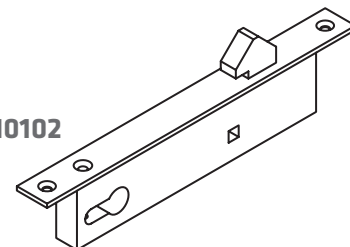

3 2 x ZB20043



4 1 x TSB-10271

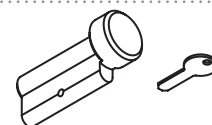

5 1 x ZB10035

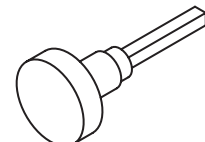

6 1 x ZB10035:2

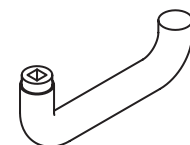

7 1 x DIN 7991-8.8-M5x35



8 1 x B00014

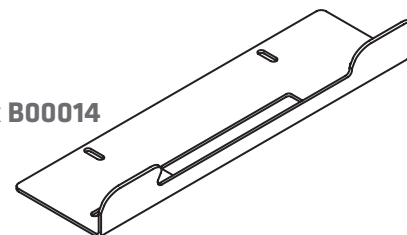

9 1 x B00012

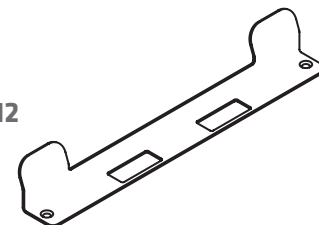

10 4 x DIN 125-8.8-A6.4



11 2 x DIN 7991-M5x20



12 2 x DIN 7991-M6x20



13 2 x DIN 912-8,8-M6x20



14 2 x DIN 934-8,8-M6



5.4. Installation of 1-leaf sliding door
Installation version DIN RIGHT / installation height 2053 mm

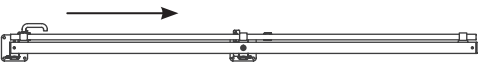

B00024

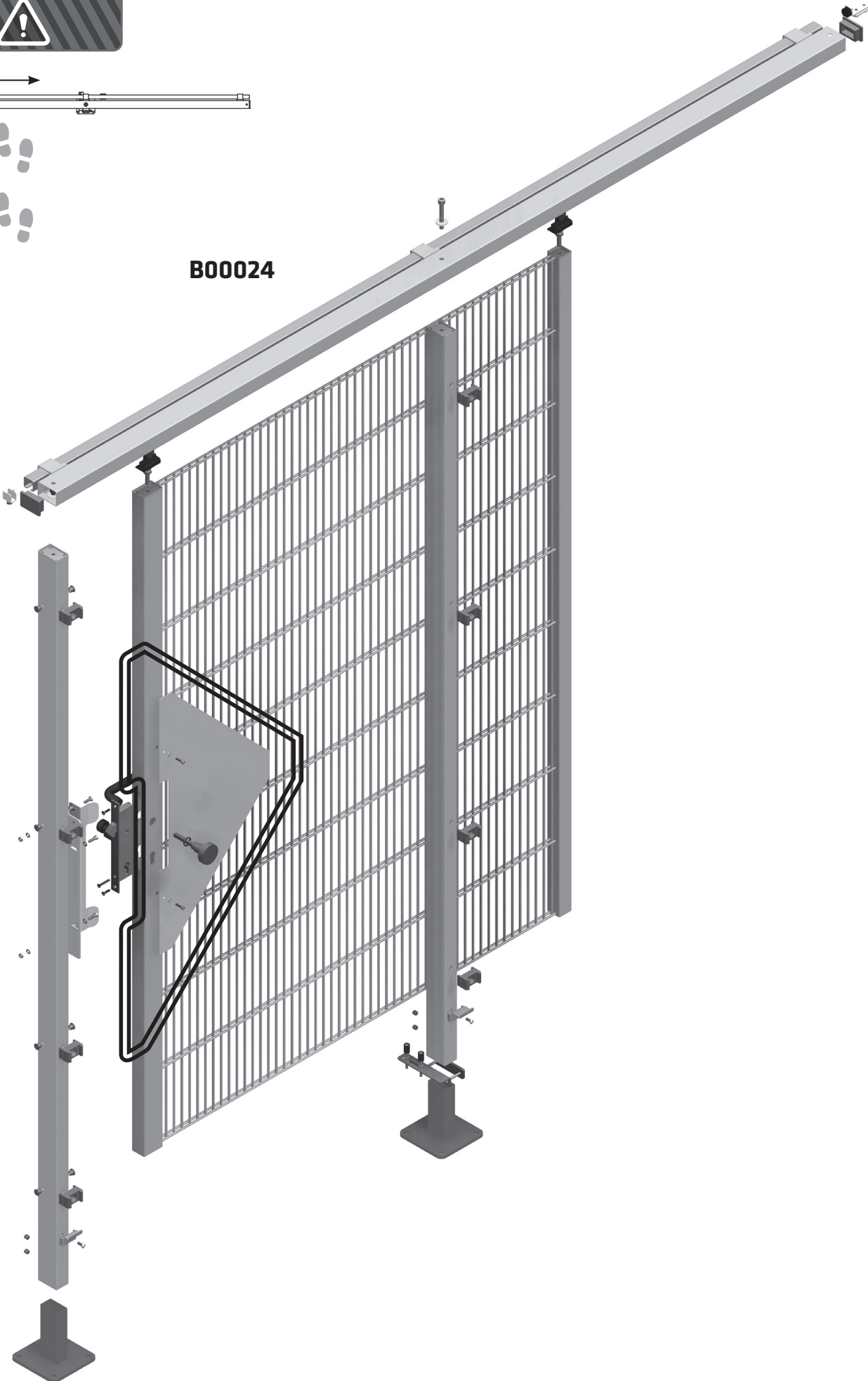

5.4. Installation of 1-leaf sliding door Installation version DIN RIGHT / installation height 2053 mm



See page 9

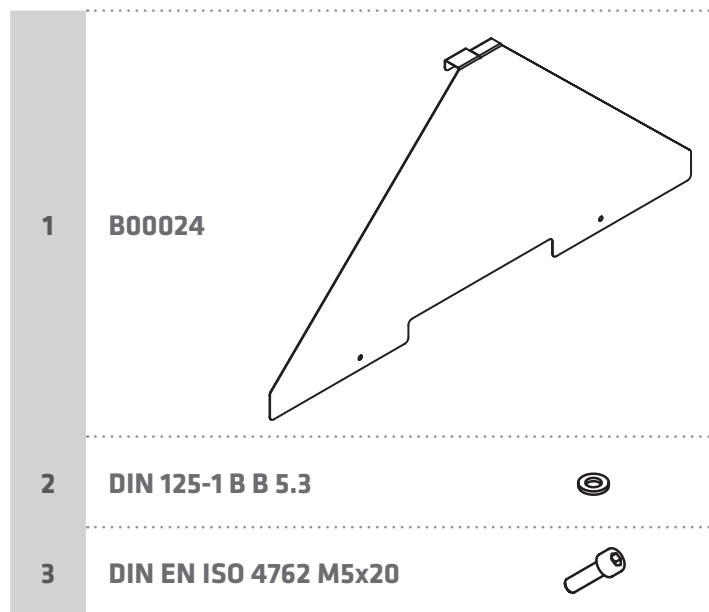
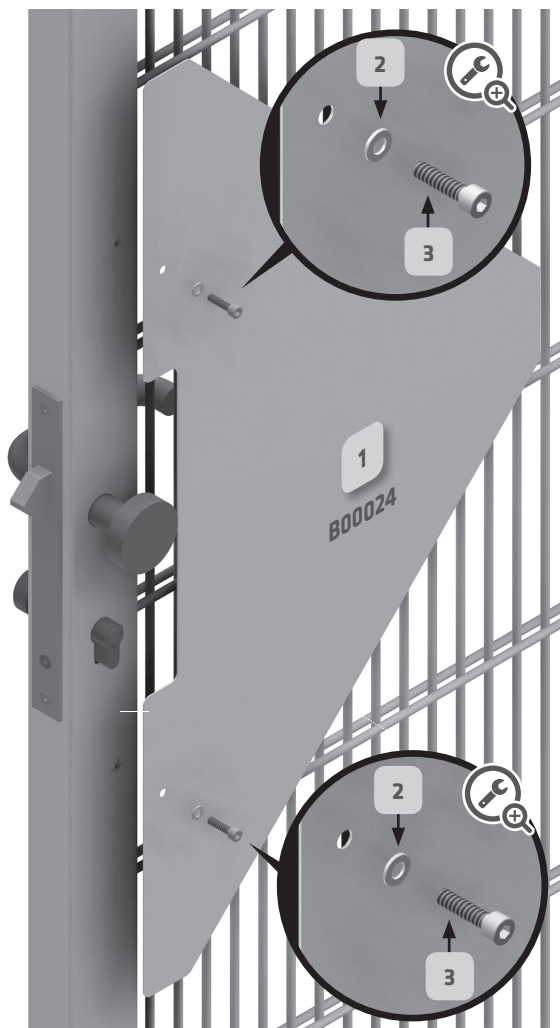

View with
installation completed

5.4. Installation of 1-leaf sliding door
Installation version DIN RIGHT / installation height 2053 mm

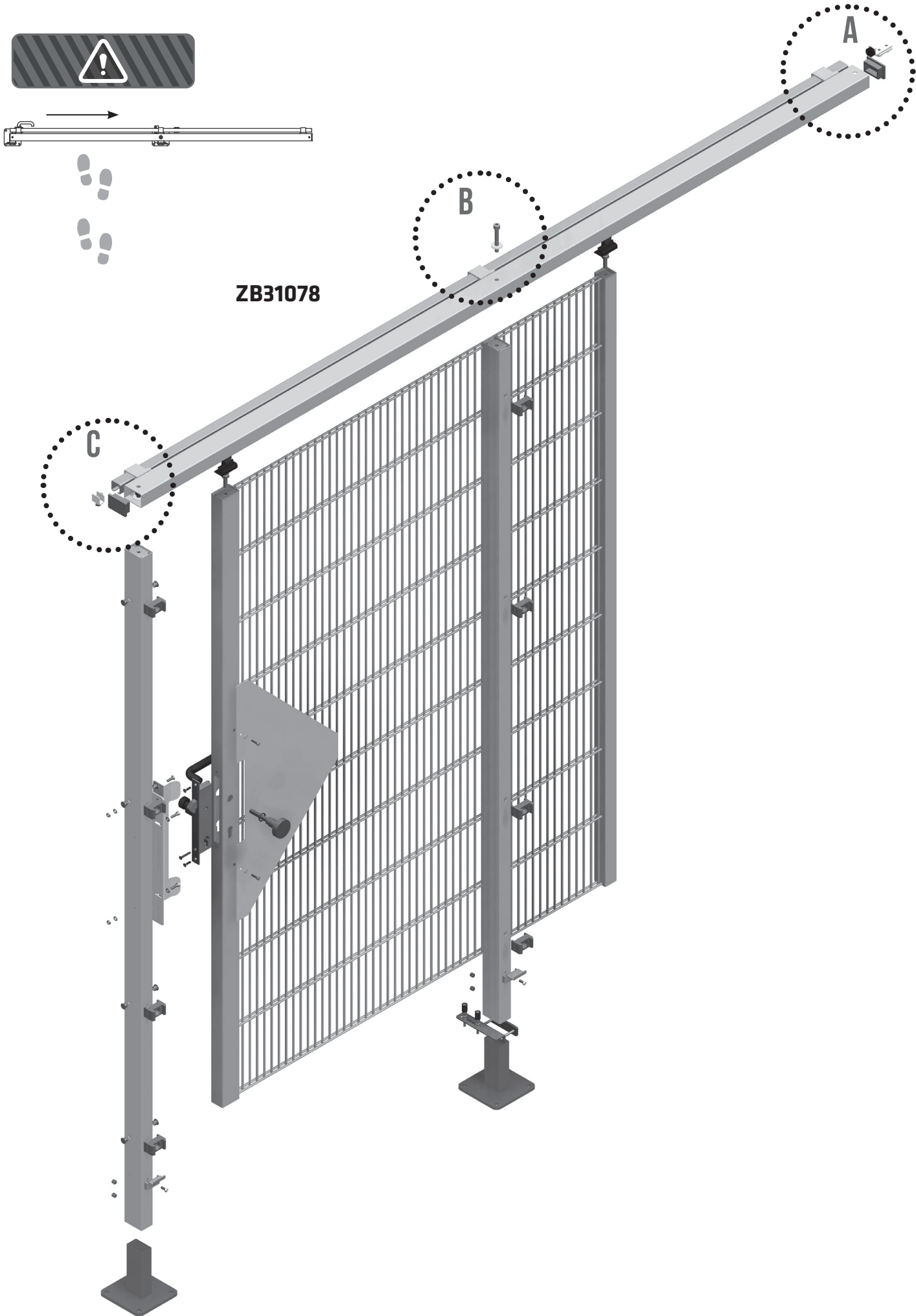

5.4. Installation of 1-leaf sliding door
Installation version DIN RIGHT / installation height 2053 mm



See page 9

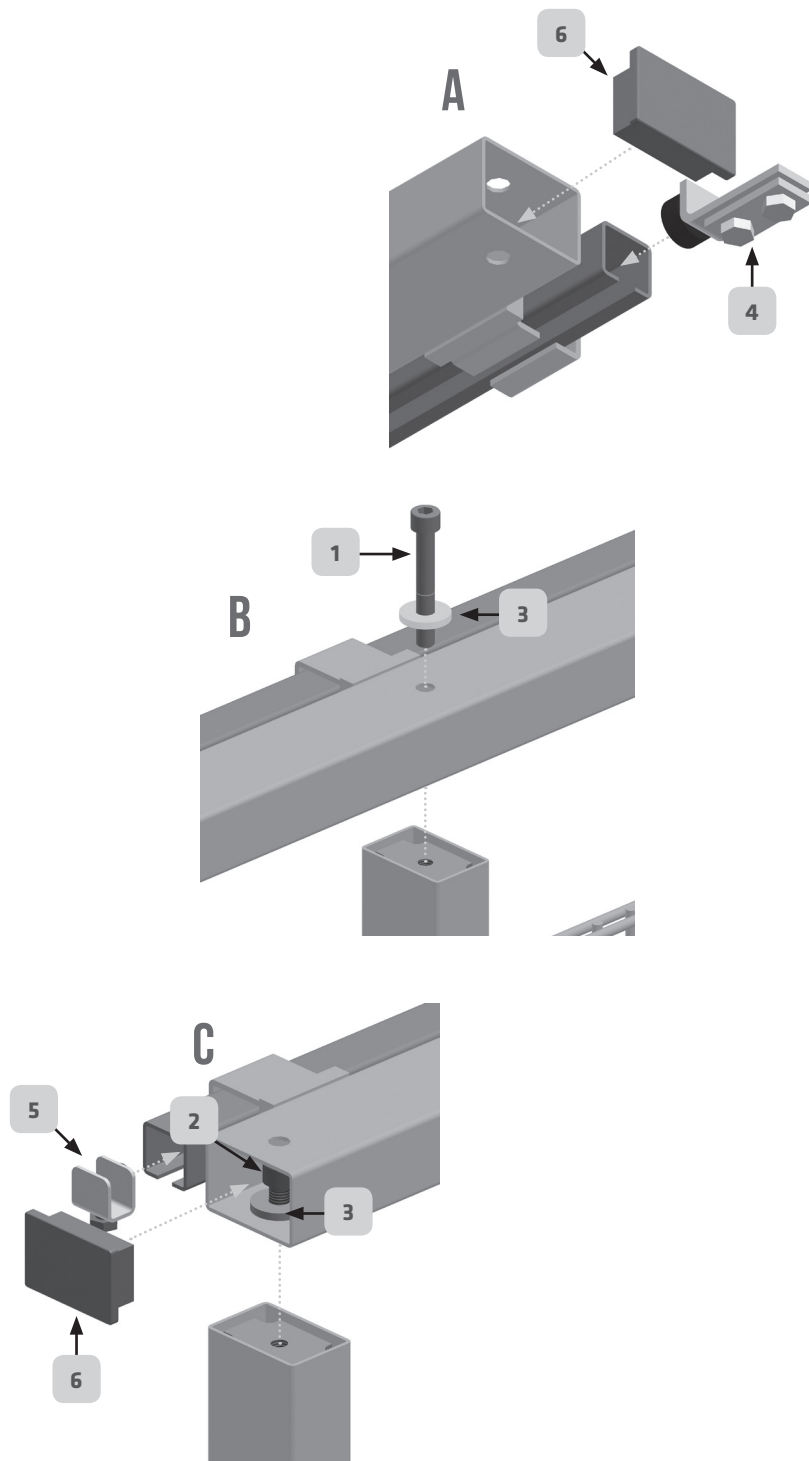

ZB31078		
1	1 x DIN912-8,8-M10x70	
2	1 x DIN912-8.8-M10x20	
3	2 x DIN6340-10,5x28x4	
4	1 x ZB20070	
5	1 x ZB20071	
6	2 x ZB20096	

View with installation completed

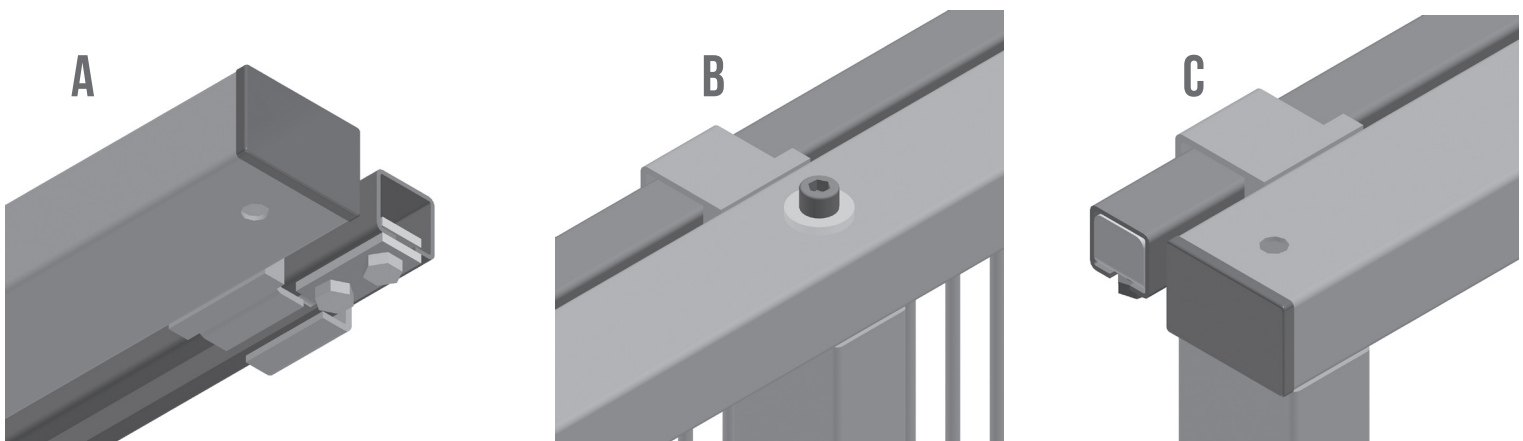



5.5. Installation on the protective mesh

Installation version DIN LEFT

 2053 / 2253 mm

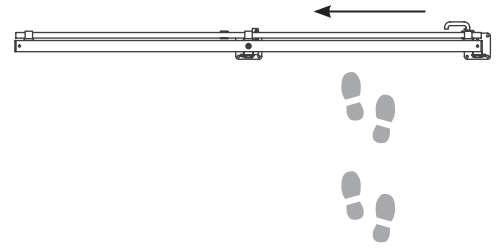
 See page 9



By Mesh assembly
always make sure that the correct number of vertical mesh rods are in the clamping element
(see Fig. 1 und 2)

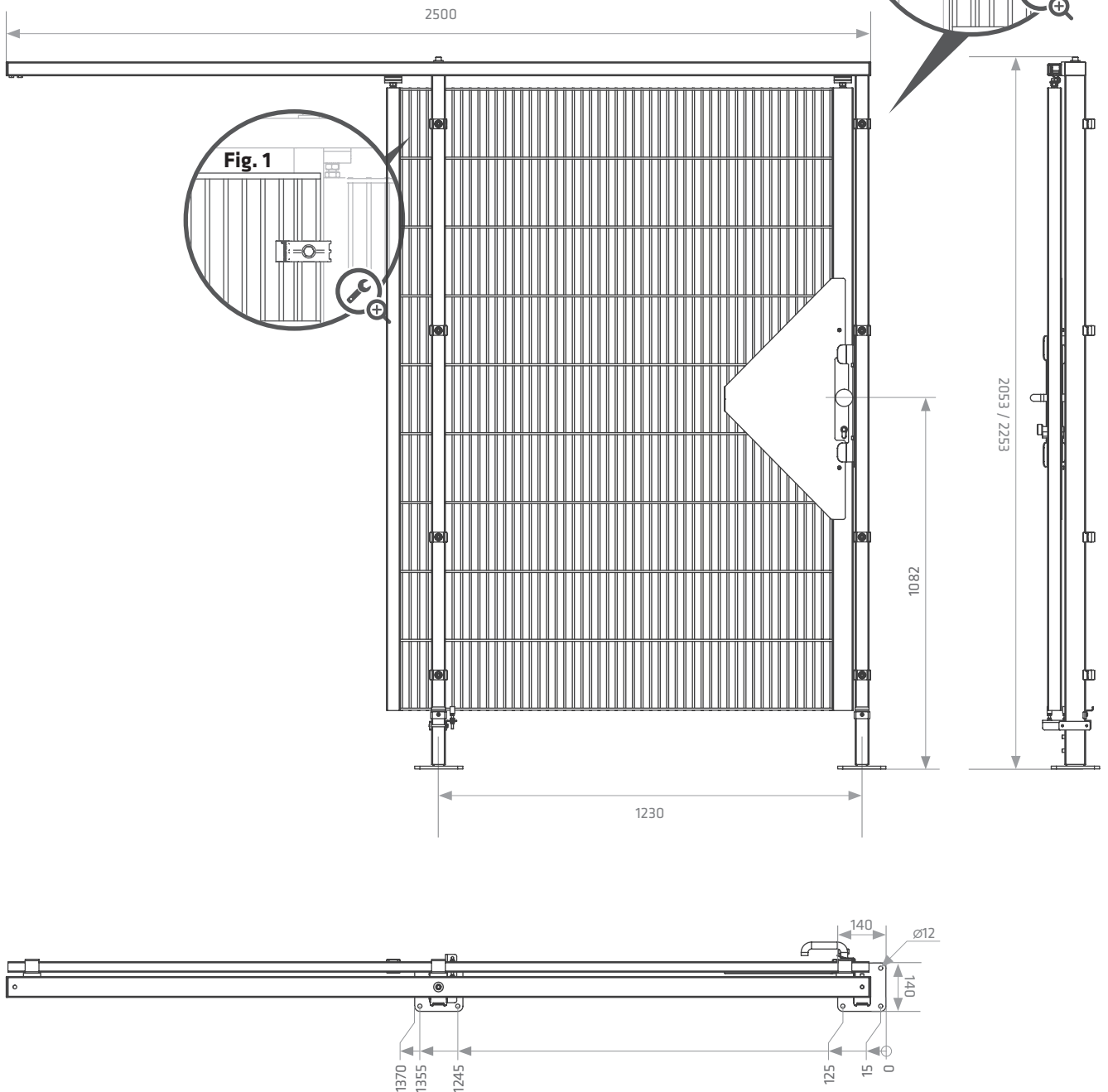

5.5. Installation on the protective mesh

Installation version DIN RIGHT



2053 / 2253 mm



See page 9

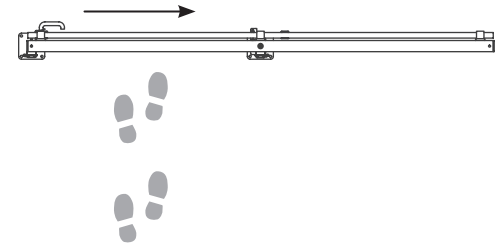

**By Mesh assembly
always make sure that the correct number of vertical mesh
rods are in the clamping element
(see Fig. 1 und 2)**

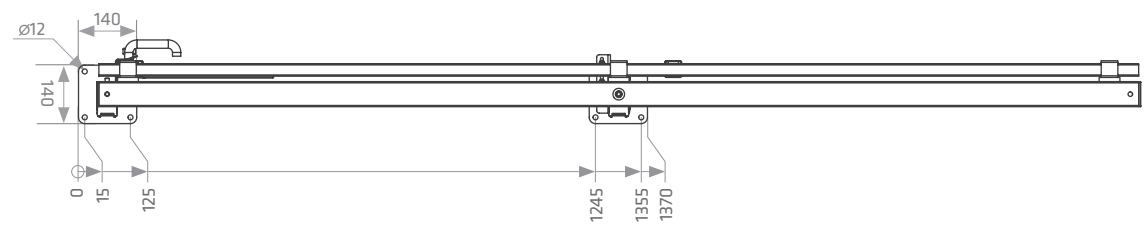
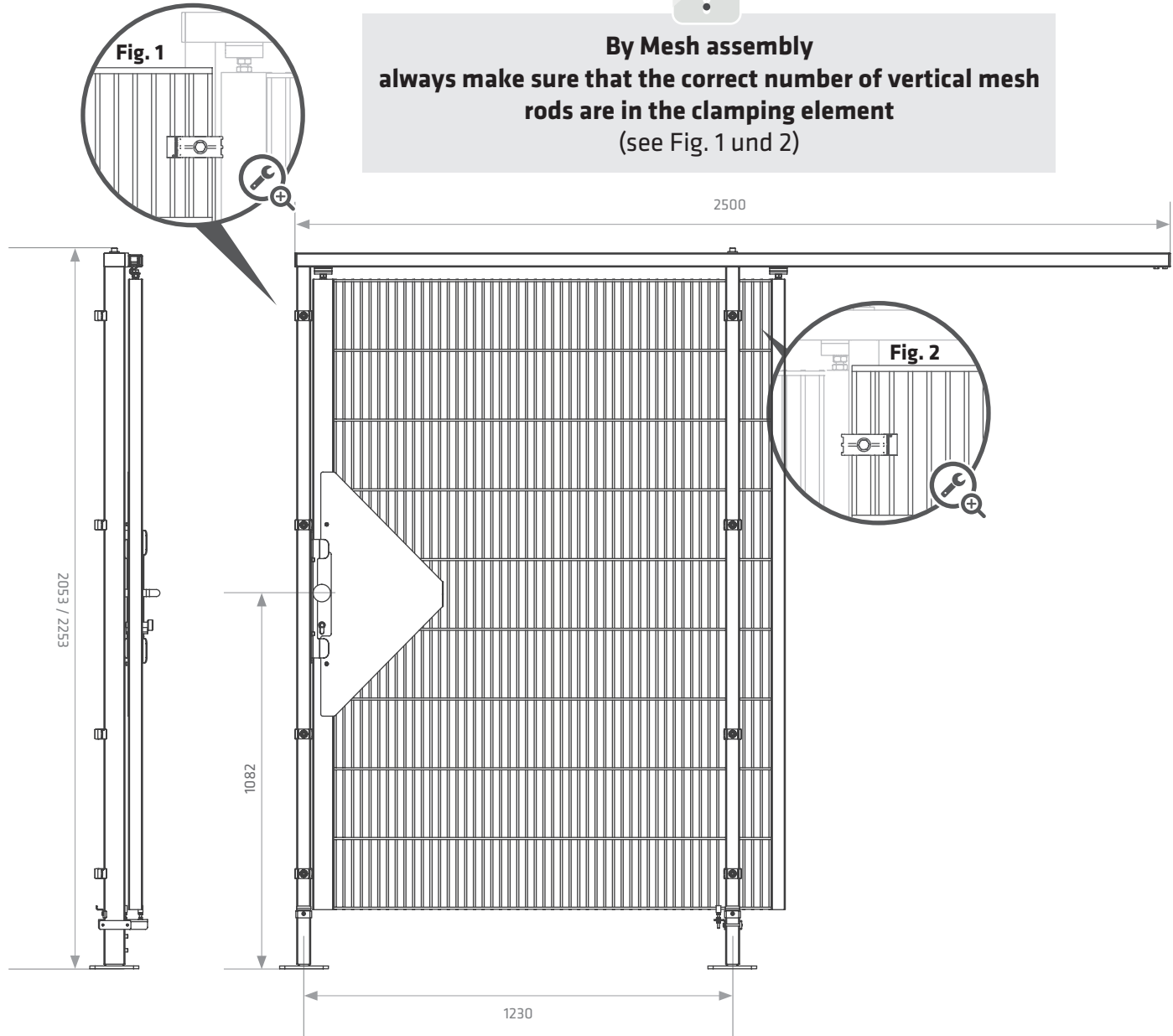

6. Maintenance

The ECONFENCE® protective fencing system is essentially maintenance-free.



Annual checks are to be carried out by specialist personnel to ensure its protective function remains intact. Missing and/or damaged parts must be completed or replaced immediately, taking health and safety at work into account. Only original spare parts may be used.

7. Disassembly and disposal

At least two people are required for disassembly work and these must be specialist personnel.



The machine / system must be switched off before disassembly and secured against unauthorised restarting by means of a lockout/tagout lock. The key must always be carried on your person.

Any electrical equipment attached to the protective fencing system must be disconnected or else made safe.

The system must be disposed of in line with local regulations.

8. Spare parts and accessories

Unless stated otherwise, all the article numbers given in these operating instructions are order numbers at the same time.

Order no.	Designation	Fig.
ZB10076	Pin chuck for mesh support (wooden)	1
ZB21012	Mesh support, corner post (drive-in version), black plastic, for a post profile measuring 60x40mm	2
ZB31048	Lower mesh connector for BL universal corner post for post profile 60x40mm, with screw	3
ZB20025	Hilti stud anchor, galvanised steel, HSA M10x113 50/40/10 for non-cracked concrete	
ZB40005	Mesh customisations and recesses according to customer layout	

Technical specifications subject to change.

 Should you have any further questions, please contact us on +49 (0) 5223 791995-0.



Abb.1



Abb.2

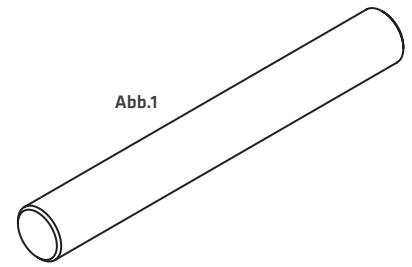

Abb.3

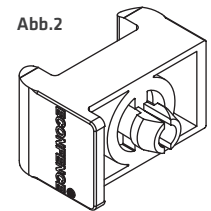

...we protect people!

TIEMANN
Schutz-Systeme GmbH
Lübbecker Straße 16
32257 Bünde
Germany
Fon +49 (0)5223 791995-0
Fax +49 (0)5223 791995-90
www.econfence.com
info@econfence.com

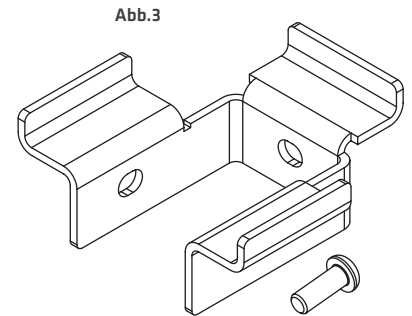

BA-100006-2